

Device/PLC Connection Manuals



About the Device/PLC Connection Manuals

Prior to reading these manuals and setting up your device, be sure to read the "Important: Prior to reading the Device/PLC Connection manual" information. Also, be sure to download the "Preface for Trademark Rights, List of Units Supported, How to Read Manuals and Documentation Conventions" PDF file. Furthermore, be sure to keep all manual-related data in a safe, easy-to-find location.



2.13 GE Fanuc Automation

2.13.1 System Structure

The following describes the system structure for connecting the GP to GE Fanuc PLCs.

Reference The Cable Diagrams mentioned in the following tables are listed in the section titled "2.13.2 Cable Diagrams".

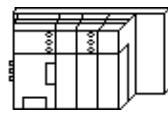
■ Series 90-30 (using SNP-X Protocol/Link I/F)

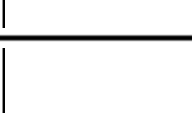
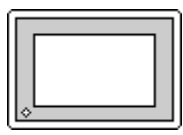
CPU	Link I/F	Cable Diagram	GP
	Communication Module 		
CPU311, CPU331	IC693CMM311 ^{*1 *2}	RS-232C (Cable Diagram 1)	GP series

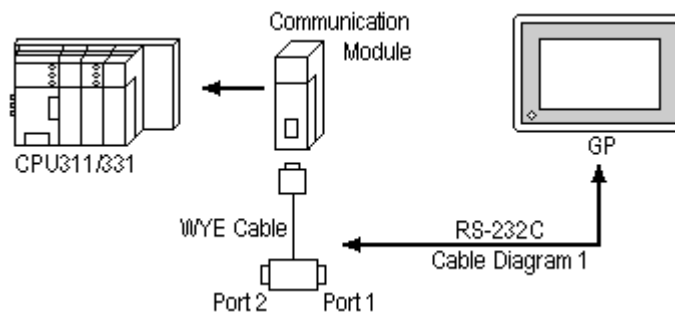

* 1 When using the SIO module (IC693CMM311), the PLC's WYE cable is necessary.



Connect to Port 1 or Port 2. However, when connected to Port 2, switch to RS-232C in the programming console. Both Port 1 and Port 2 can be connected at the same time to two GPs.

* 2 Select SNP-X protocol using the programming console.

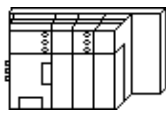

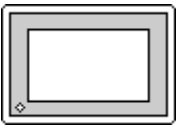
■ **Series 90-30** (SNP-X Protocol/CPU Direct Connection)

CPU	Cable Diagram	GP
		
CPU311, CPU331	RS-422 (Cable Diagram 2)	GP series

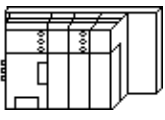

Communication speed is faster than when using the SIO module, however, you cannot use the programming console and the GP at the same time.

■ **Series 90-70** (using SNP-X Protocol/Link I/F)

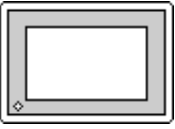
CPU	Link I/F	Cable Diagram	GP
	 SIO Module		
CPU731/732, CPU771/772, CPU781/782	IC697CMM711 ^{*1,*2}	RS-232C (Cable Diagram 1) RS-422 (Cable Diagram 3)	GP series



*1 Select SNP-X protocol using the programming console.

*2 Connect to the SIO module's Port 1 or Port 2, and change to RS-232C or RS-422/485 with the programming console. Cannot connect GPs to both Port 1 and Port 2.





Places noted as RS-422 can also use RS-485 on the PLC side.

■ Series 90-30 (SNP Protocol, CPU Direct Connection)

CPU	Cable Diagram	GP
		
CPU311 CPU350 CSE311 CPU313 CPU351 CSE313 CPU323 CPU352 CSE323 CPU331 CPU360 CSE331 CPU340 CPU363 CSE340 CPU341 CPU364	RS422 <Cable Diagram 2> RS422 (1:n connection) <Cable Diagram 4>	GP Series units

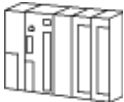
■ Series 90-70 (SNP Protocol, CPU Direct Connection)

CPU	Cable Diagram	GP
		
CPU731 CPU789 CSE924 CPU771 CPM915 CSE925 CPU772 CPM925 CPX772 CPU780 CPX935 CPX782 CPU781 CGR935 CPX928 CPU782 CPM790 CGR772 CPU788 CSE784	RS422 <Cable Diagram 2> RS422 (1:n connection) <Cable Diagram 4>	GP Series units



- Up to 32 PLCs can be connected to one GP.
- Be sure that only one (a single) GP unit is connected to this system.

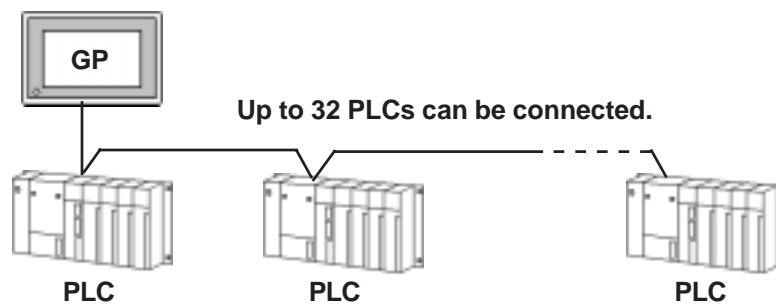

- If multiple PLCs are used, the GP screen's refresh speed may slow when any of the following conditions occur.
 - When a single GP screen is used to monitor many PLCs.
 - When a single GP screen's Part or Tag address settings are not consecutive.

To keep the GP's screen refresh speed as high as possible, the following points are recommended.

- Do not monitor more than three (3) PLCs on one GP screen.
- Try to keep each screen's Part items and Tag address settings consecutive.

2.13.2 Cable Diagrams

The cable diagrams illustrated below and the cable diagrams recommended by GE Fanuc Automation may differ, however, using these cables for your PLC operations will not cause any problems.



- Ground your PLC's FG terminal according to your country's applicable standard. For details, refer to the corresponding PLC manual.



- Connect the FG line of the Shield cable to either the GP or PLC, depending on your environment. When using a connector hood and grounding the FG line, be sure to use an electrical conductor.
- For the RS-232C connection, use a cable length less than 15m.
- Different PLC manuals will write their RS-422 connection drawings (i.e. RD (A), RD (B), SD (A), and SD (B)) differently. Thus, be sure to refer to your specific PLC's manual for this information. The following connection diagrams show examples for connecting a shielded cable to the PLC.
- If a communications cable is used, it must be connected to the SG (signal ground).

Cable Diagram 1 (RS-232C)

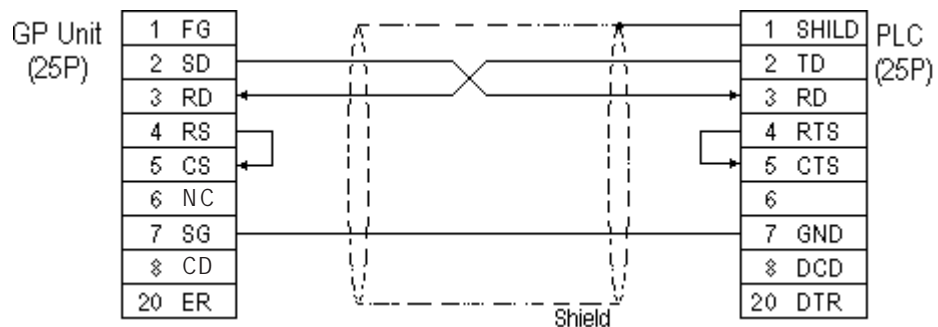

Cable Diagram 2 (1:1) (RS-422)

- When using Digital's RS-422 connector terminal adapter GP070-CN10-0

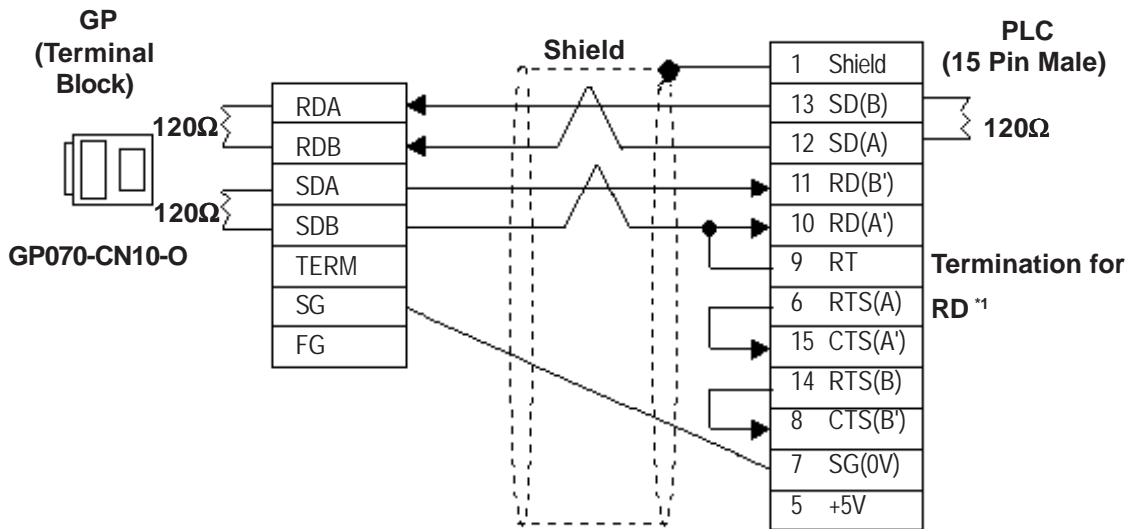

- When making your own cable

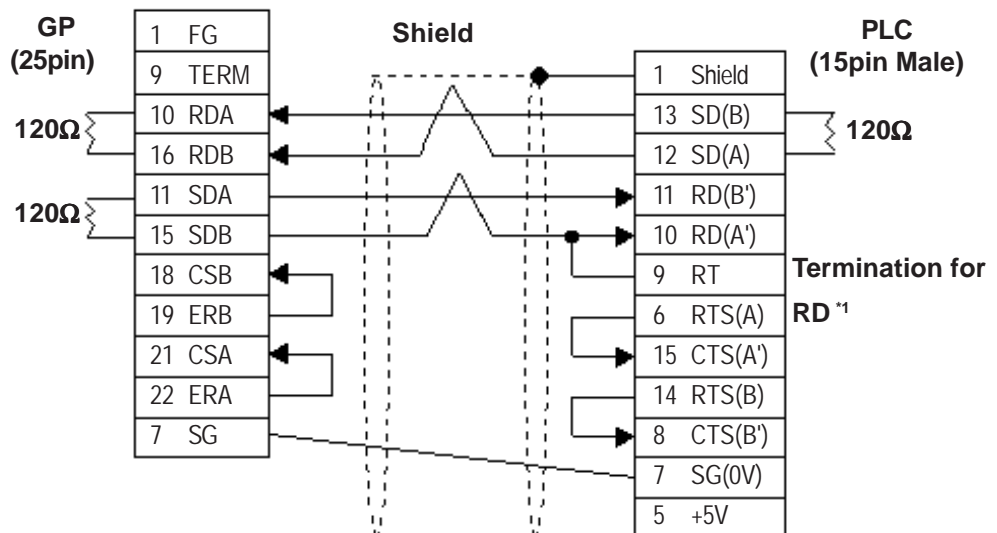

*1 When connecting #9 and #10 pins in the GP Serial I/F, a termination resistance of 120Ω is added between RD-(A') and RD-(B'). When using CPU731 and CPU771, a termination resistance of 120Ω is added between RD-(A') and RD-(B') connecting #9 and #11 pins.



Important

- **Ground your Controller's FG terminal according to your country's applicable standard. For details, refer to the corresponding Controller's manual.**
- **When connecting a cable's Shield line to an FG terminal, consider the needs of your system when deciding which side of the cable (GP or Controller) to connect. (The example below connects to the Controller's FG terminal.)**
- **Be aware the A and B signals of the GP and PLC are opposite to each other.**
- **The cable length must be 600 meters or less.**

Cable Diagram 3 (RS-422)

- When using Digital's RS-422 connector terminal adapter GP070-CN10-0

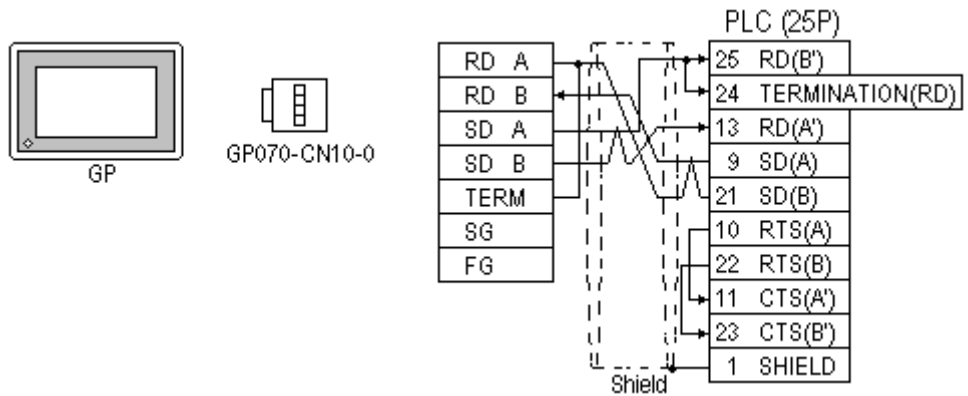

- When using Digital's RS-422 Cable, GP230-IS11-0

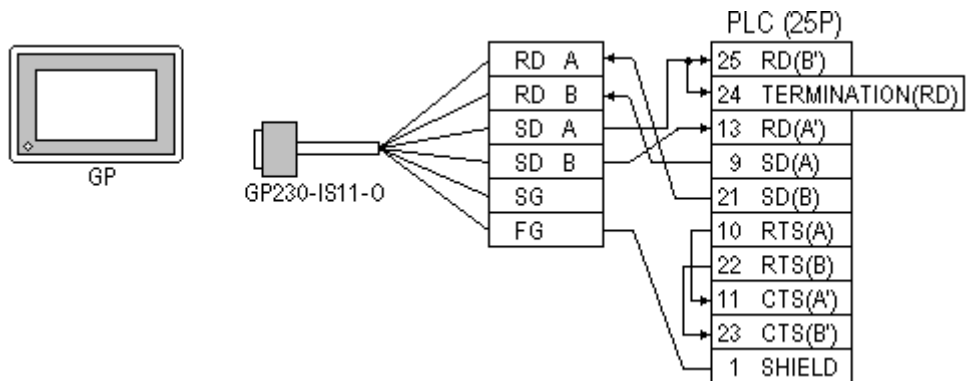

- When making your own cable connections

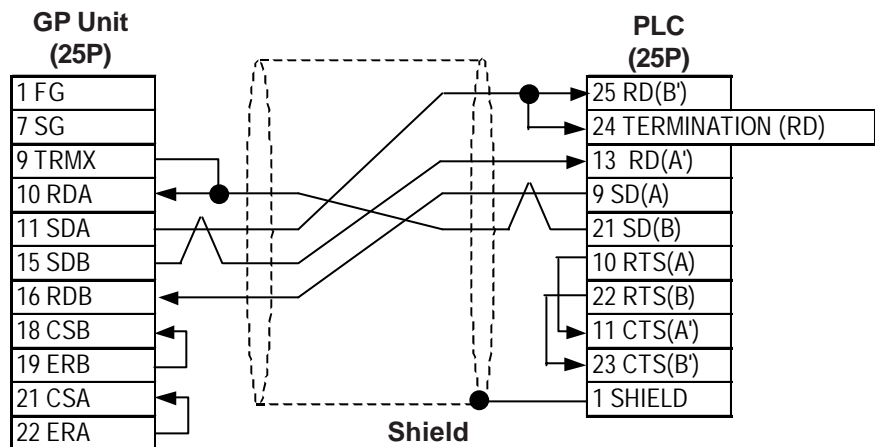

- When connecting the #9 and #10 pins in the GP Serial I/F, a termination resistance of 100Ω is added between RDA and RDB.
- When using RS-422 connection, please check the cable length with GE Fanuc Automation PLC's users manual.

Cable Diagram 4 (1:n) (RS-422)

- When using Digital's RS-422 connector terminal adapter GP070-CN10-0

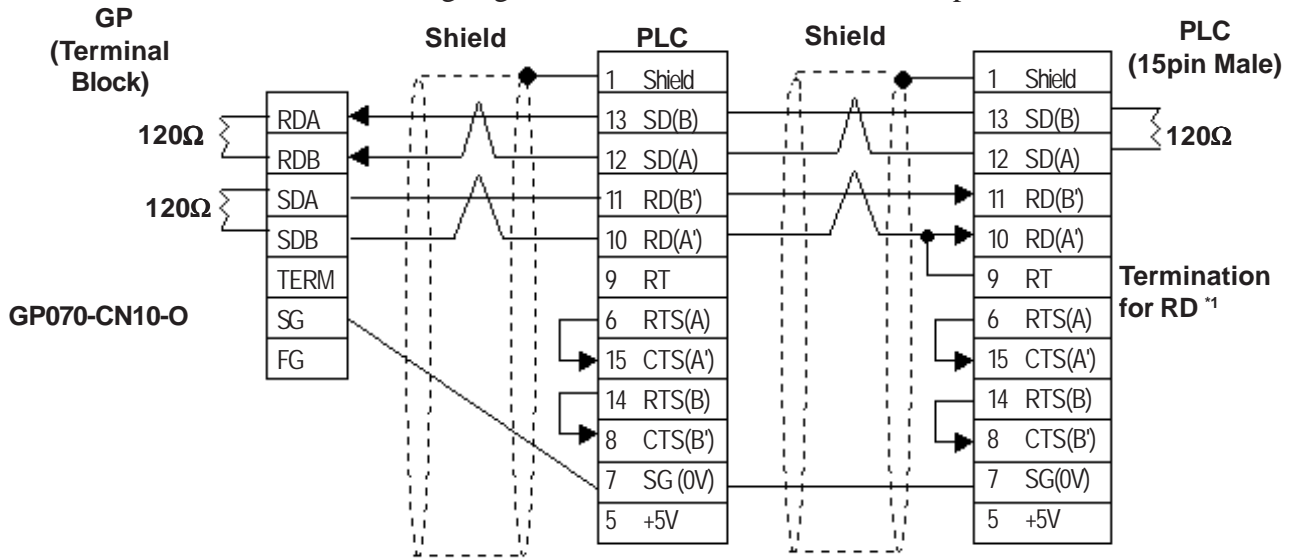

- When making your own cable

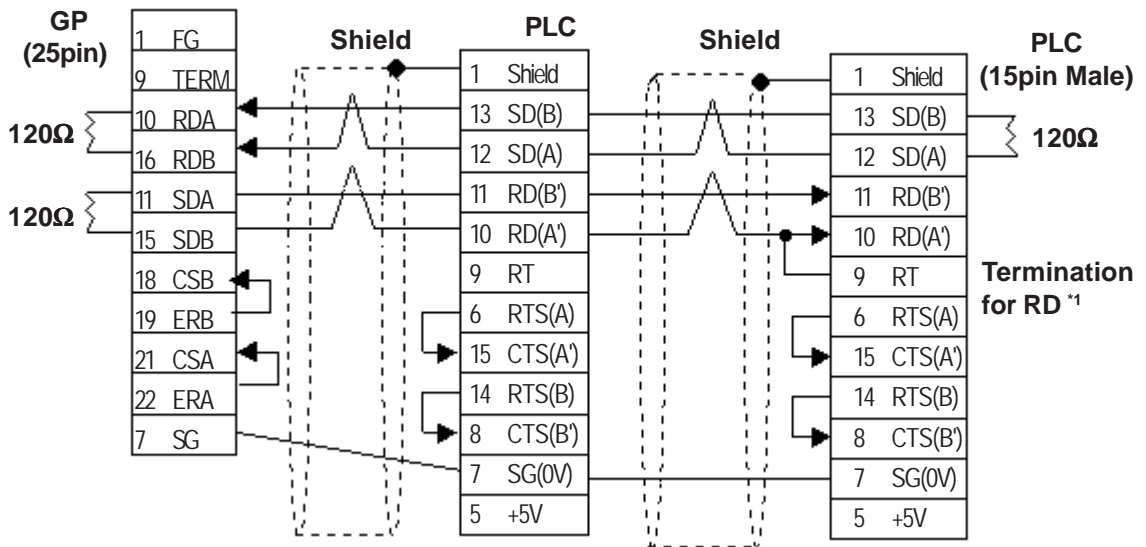

*1 When connecting #9 and #10 pins in the GP Serial I/F, a termination resistance of 120Ω is added between RD-(A') and RD-(B'). When using CPU731 and CPU771, a termination resistance of 120Ω is added between RD-(A') and RD-(B') connecting #9 and #11 pins.



- **Ground your Controller's FG terminal according to your country's applicable standard. For details, refer to the corresponding Controller's manual.**
- **When connecting a cable's Shield line to an FG terminal, consider the needs of your system when deciding which side of the cable (GP or Controller) to connect. (The example below connects to the Controller's FG terminal.)**
- **Be aware the A and B signals of the GP and PLC are opposite to each other.**
- **The cable length must be 600 meters or less.**

2.13.3 Supported Devices

The following tables describe the range of devices supported by the GP.

■ **Series 90-70/90-30 (SNP-X protocol)**

Setup System Area here.

Device	Bit Address	Word Address	Particulars
Input Relay (I)	I0001 ~ I12288	I00001 ~ I12273	÷16+
Output Relay (Q)	Q00001 ~ Q12288	Q0001 ~ Q12273	÷16+
Internal Relay (M)	M00001 ~ M12288	M0001 ~ M12273	÷16+
Global Relay (G)	G0001 ~ G7680	G0001 ~ G7665	÷16+
Momentary Relay (T)	T001 ~ T256	T001 ~ T241	÷16+
System Function Relay (SA)	SA001 ~ SA128	SA001 ~ SA113	÷16+
System Function Relay (SB)	SB001 ~ SB128	SB001 ~ SB113	÷16+
System Function Relay (SC)	SC001 ~ SC128	SC001 ~ SC113	÷16+
System Function Relay (S)	S001 ~ S128	S001 ~ S113	÷16+ *1
Register (R)	---	R00001 ~ R32640	Bit 5
Analog Input (AI)	---	AI0001 ~ AI32640	Bit 5
Analog Output (AQ)	---	AQ0001 ~ AQ32640	Bit 5

L/H

*1 Data cannot be written to this relay. If data is written, a host communication error (02:0F:03) will be displayed.



Depending on the CPU used, the devices address ranges may differ.

■ GE Fanuc 90-30/90-70 (SNP protocol)

 Setup System Area here.

Device	Bit Address	Word Address	Comments
Input Relay (I)	I00001 - I12288	I00001 - I12273	÷16+1
Output Relay (Q)	Q00001 - Q12288	Q00001 - Q12273	÷16+1
Internal Relay (M)	M00001 - M12288	M00001 - M12273	÷16+1
Global Relay (G)	G0001 - G7680	G0001 - G7665	÷16+1
Temporary Relay (T)	T001 - T256	T001 - T241	÷16+1
System Status Relay (SA)	SA001 - SA128	SA001 - SA113	÷16+1
System Status Relay (SB)	SB001 - SB128	SB001 - SB113	÷16+1
System Status Relay (SC)	SC001 - SC128	SC001 - SC113	÷16+1
System Status Relay (S)	S001 - S128	S001 - S113	÷16+1
Register (R)	-----	R00001 - R01024	Bit 5
	-----	R01025 - R02048	
	-----	R02049 - R03072	
	-----	R03073 - R04096	
	-----	R04097 - R05120	
	-----	R05121 - R06144	
	-----	R06145 - R07168	
	-----	R07169 - R08192	
	-----	R08193 - R09216	
	-----	R09217 - R10240	
	-----	R10241 - R11264	
	-----	R11265 - R12288	
	-----	R12289 - R13312	
	-----	R13313 - R14336	
	-----	R14337 - R15360	
	-----	R15361 - R16384	
	-----	R16385 - R17408	
	-----	R17409 - R18432	
	-----	R18433 - R19456	
	-----	R19457 - R20480	
	-----	R20481 - R21504	
	-----	R21505 - R22528	
	-----	R22529 - R23552	
	-----	R23553 - R24576	
	-----	R24577 - R25600	
	-----	R25601 - R26624	
	-----	R26625 - R27648	
	-----	R27649 - R28672	
	-----	R28673 - R29696	
	-----	R29697 - R30720	
	-----	R30721 - R31744	
	-----	R31745 - R32640	

L/H

Device	Bit Address	Word Address	Comments
Analog Input (AI)	-----	AI0001 ~ AI1024	Bit 5 L/H
	-----	AI1025 ~ AI2048	
	-----	AI2049 ~ AI3072	
	-----	AI3073 ~ AI4096	
	-----	AI4097 ~ AI5120	
	-----	AI5121 ~ AI6144	
	-----	AI6145 ~ AI7168	
	-----	AI7169 ~ AI8192	
	-----	AI8193 ~ AI9216	
	-----	AI9217 ~ AI10240	
	-----	AI10241 ~ AI11264	
	-----	AI11265 ~ AI12288	
	-----	AI12289 ~ AI13312	
	-----	AI13313 ~ AI14336	
	-----	AI14337 ~ AI15360	
	-----	AI15361 ~ AI16384	
	-----	AI16385 ~ AI17408	
	-----	AI17409 ~ AI18432	
	-----	AI18433 ~ AI19456	
	-----	AI19457 ~ AI20480	
	-----	AI20481 ~ AI21504	
	-----	AI21505 ~ AI22528	
	-----	AI22529 ~ AI23552	
	-----	AI23553 ~ AI24576	
	-----	AI24577 ~ AI25600	
	-----	AI25601 ~ AI26624	
	-----	AI27649 ~ AI28672	
	-----	AI28673 ~ AI29696	
-----	AI29697 ~ AI30720		
-----	AI30721 ~ AI31744		
-----	AI31745 ~ AI32640		
Analog Output (AQ)	-----	AQ0001 ~ AQ1024	Bit 5 L/H
	-----	AQ1025 ~ AQ2048	
	-----	AQ2049 ~ AQI3072	
	-----	AQ3073 ~ AQ4096	
	-----	AQ4097 ~ AQ5120	
	-----	AQ5121 ~ AQ6144	
	-----	AQ6145 ~ AQ7168	
	-----	AQ7169 ~ AQ8192	
	-----	AQ8193 ~ AQ9216	
	-----	AQ9217 ~ AQ10240	
	-----	AQ10241 ~ AQ11264	
	-----	AQ11265 ~ AQ12288	
	-----	AQ12289 ~ AQ13312	
	-----	AQ13313 ~ AQ14336	
	-----	AQ14337 ~ AQ15360	
	-----	AQ15361 ~ AQ16384	
	-----	AQ16385 ~ AQ17408	
	-----	AQ17409 ~ AQ18432	
	-----	AQ18433 ~ AQ19456	
	-----	AQ19457 ~ AQ20480	

Device	Bit Address	Word Address	Comments	
Analog Output (AQ)	-----	AQ20481 ~ AQ21504	<div style="border: 1px solid black; padding: 2px; display: inline-block;">Bit 15</div>	L/H
	-----	AQ21505 ~ AQ22528		
	-----	AQ22529 ~ AQ23552		
	-----	AQ23553 ~ AQ24576		
	-----	AQ26625 ~ AQ27648		
	-----	AQ27649 ~ AQ28672		
	-----	AQ28673 ~ AQ29696		
	-----	AQ29697 ~ AQ30720		
	-----	AQ30721 ~ AQ31744		
	-----	AQ31745 ~ AQ32640		



Depending on the CPU used, the devices address ranges may differ.



- If bit write is performed using the bit designation feature in any of these Bit 15 devices, all bits except the designated bit will turn to "0".
- The range of each device's address will vary depending on the CPU type.



- When setting up Tags and Parts in GP-PRO/PBIII for Windows, the PLC CPU ID number can also be designated. If a CPU ID number is not specified, the previously entered CPU ID number is automatically used. (The default value is "01".)

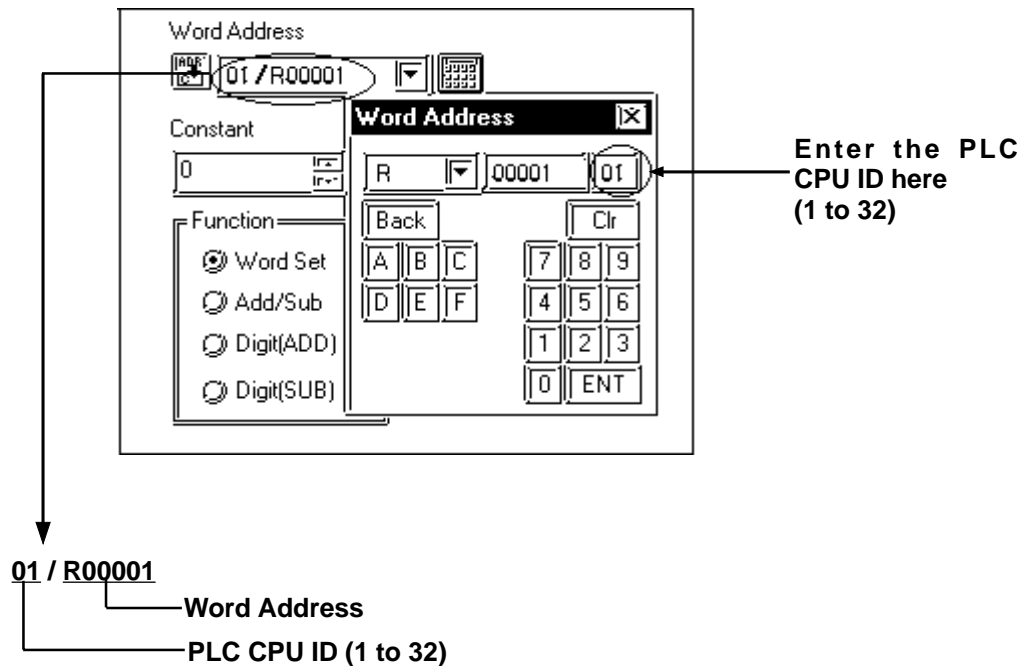

<Driver Usage Restriction>

- When using 1:n connection, the R, AI and AQ devices data areas are each 1024 words on your GP application. You cannot extend over more than one data "block" when performing the following features. Be sure to set these features' settings so they are within one data block.
 - System Area Settings
 - "a-tag " settings
 - Performing Block read/write using the 2-Way feature
 Ex) You cannot set a 20 word-data block starting from R1020.
- When setting a PLC's CPU ID, be sure to use a number from "1" to "32" as the CPU ID so that the selected number is used as the PLC's unit number.

2.13.4 Environment Setup

The following tables list Digital's recommended PLC and GP communication settings.

■ **Series 90-30 (SNP-X protocol, using Link I/F)**

GP Setup		SIO Module Setup	
Baud Rate	19200 bps	Baud Rate	19200 bps
Data Length	8 bits (fixed)	Data Bit	8 bits (fixed)
Stop Bit	1 bit	Stop Bit	1 bit
Parity Bit	Odd	Parity Bit	Odd
Data Flow Control	ER Control	---	
Communication Format	RS-232C	Communication Format	RS-232C ^{*1}
---		MODE	SNP ONLY
Unit No.	0 (fixed)	Station Number	0 (fixed)

■ **Series 90-30 (SNP-X protocol, CPU Direct Connection ^{*2})**

GP Setup		Communication Module Setup	
Baud Rate	19200 bps	Baud Rate	19200 bps
Data Length	8 bits (fixed)	Data Bit	8 bits (fixed)
Stop Bit	1 bit	Stop Bit	1 bit
Parity Bit	Odd	Parity Bit	Odd
Data Flow Control	ER Control	---	
Communication Format	4-wire type	---	
Unit No.	0 (fixed)	Station Number	0 (fixed)

*1 Only when connecting to Port 2. This setting is not used for Port 1.

*2 This must be set through either the ladder logic, or from the programming console unit.

■ Series 90-70 (SNP-X protocol)

GP Setup		Communication Module Setup	
Baud Rate	19200 bps	Baud Rate	19200 bps
Data Length	8 bits (fixed)	Data Bit	8 bits (fixed)
Stop Bit	1 bit	Stop Bit	1 bit
Parity Bit	Odd	Parity Bit	Odd
Data Flow Control	ER Control	---	
Communication Format (RS-232C)	RS-232C	Communication Format (RS-232C)	RS-232C
Communication Format (RS-422)	4-wire type	Communication Format (RS-422)	RS-422/485
---		MODE	SNP ONLY
Unit No.	0 (fixed)	Station Number	0 (fixed)

■ Series 90-30/90-70 (SNP protocol)

GP		PLC	
Transmission speed	19200 bps	Baud Rate	19200 bps
Data Length	8 bits (fixed)	Data Length	8 bits (fixed)
Stop Bit	1 bit	Stop Bit	1 bit
Parity Bit	Odd	Parity Bit	Odd
Data Flow Control	ER)(fixed)	---	---
Communication Format	4-wire type (fixed)	---	---
Unit No.	1	CPU ID *1	1

*1 Setting Method: when setting a PLC's CPU ID, be sure to use a number from "1" to "32" as the CPU ID so that the selected number is used as the PLC's unit number.

