

MEMOBUS Ethernet Driver

1	System Configuration.....	3
2	Selection of External Device	5
3	Example of Communication Setting.....	6
4	Setup Items.....	38
5	Supported Device.....	42
6	Device Code and Address Code.....	44
7	Error Messages.....	45

Introduction

This manual describes how to connect the Display and the External Device (target PLC).

In this manual, the connection procedure will be described by following the below sections:

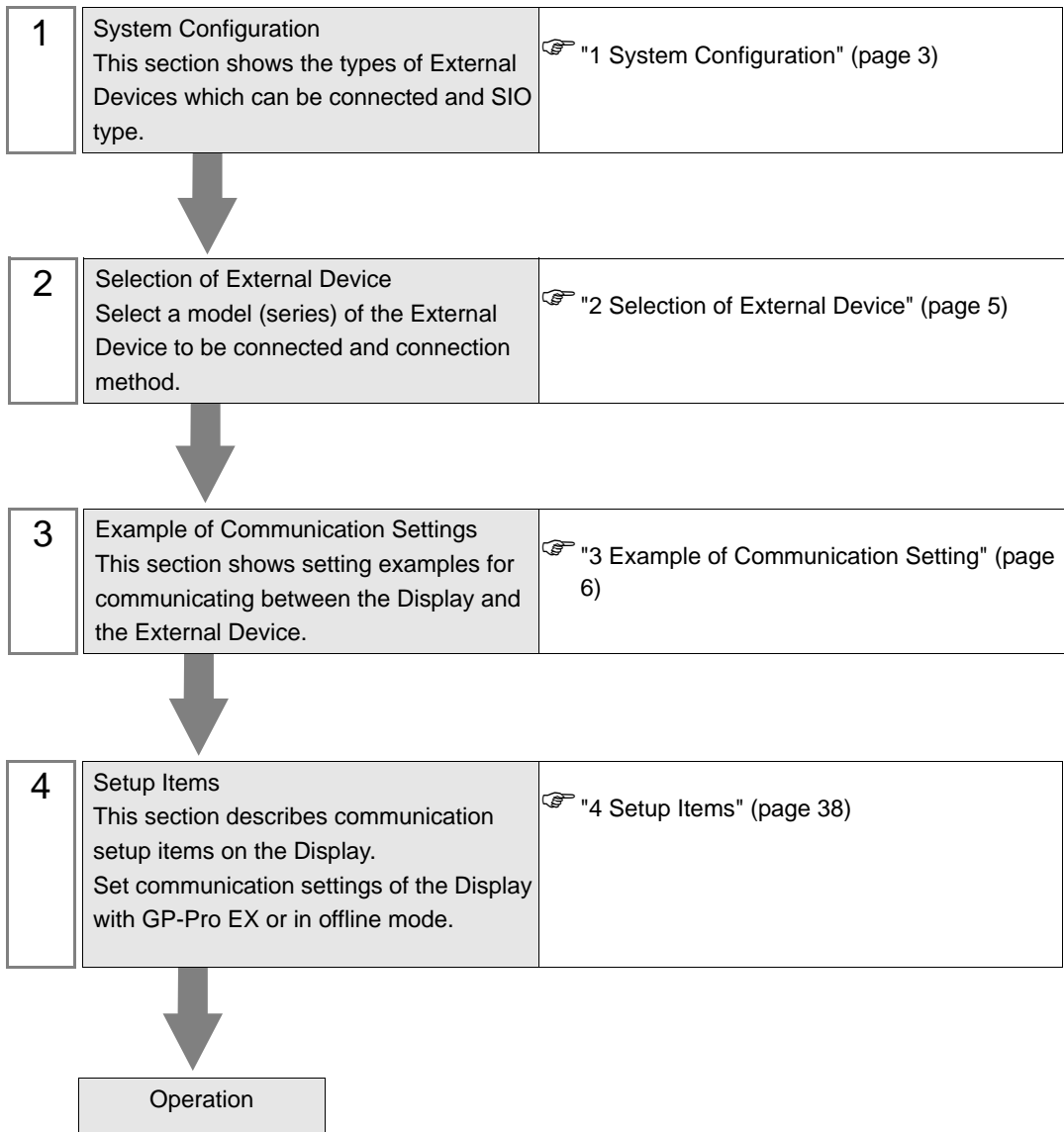

1 System Configuration

The system configuration in the case when the External Device of YASUKAWA Electric Corporation and the Display are connected is shown.

Series	CPU	Link I/F	Interface	Setting Example
MP900	MP920	Ethernet port on 218IF-01 (10BASE-5)	Ethernet (TCP)	Setting Example 1 (page 6)
			Ethernet (UDP)	Setting Example 2 (page 10)
MP2000	MP2300 MP2200	Ethernet port on 218IF-01	Ethernet (TCP)	Setting Example 3 (page 14)
			Ethernet (UDP)	Setting Example 4 (page 18)
		Ethernet port on 218IF-02	Ethernet (TCP)	Setting Example 7 (page 30)
			Ethernet (UDP)	Setting Example 8 (page 34)
	MP2310 MP2300S	Ethernet connector on CPU unit	Ethernet (TCP)	Setting Example 5 (page 22)
			Ethernet (UDP)	Setting Example 6 (page 26)
		Ethernet port on 218IF-01	Ethernet (TCP)	Setting Example 3 (page 14)
			Ethernet (UDP)	Setting Example 4 (page 18)
		Ethernet port on 218IF-02	Ethernet (TCP)	Setting Example 7 (page 30)
			Ethernet (UDP)	Setting Example 8 (page 34)
	MP2400	Ethernet connector on CPU unit	Ethernet (TCP)	Setting Example 5 (page 22)
			Ethernet (UDP)	Setting Example 6 (page 26)

NOTE • This driver does not support GP-4100 series and GP-4*0ITM.

■ Connection Configuration

- 1:1 Connection

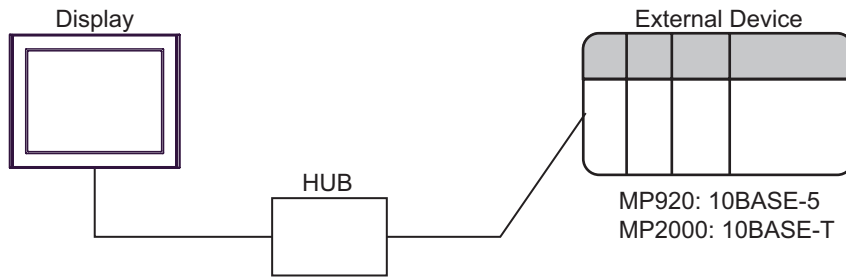

- 1:n Connection

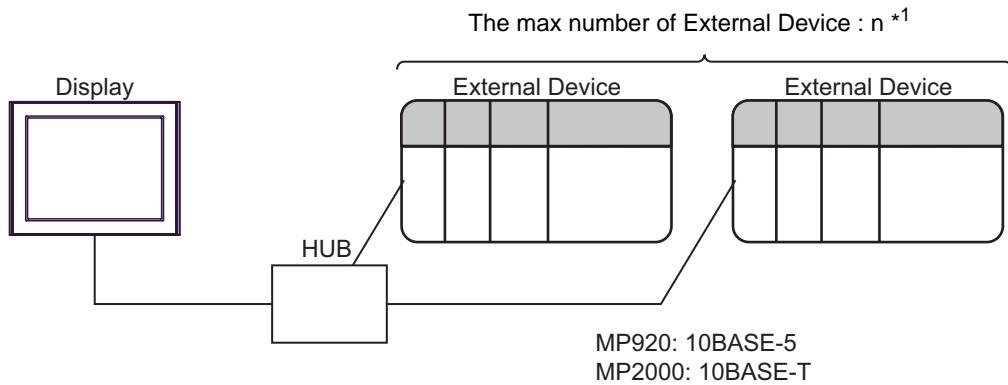

*1 The maximum 32 External Devices connection by UDP connection, the maximum 16 External Devices connection by TCP connection.

- n:1 Connection

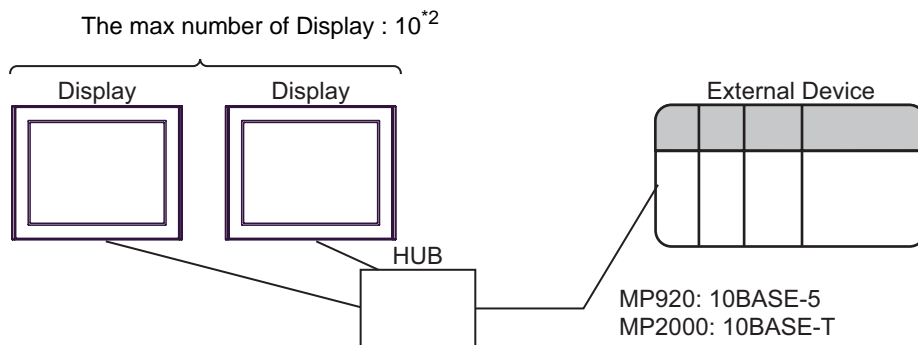

*2 When Ethernet port on CPU unit in MP2310/MP2300S/MP2400 is used, up to 4 Displays can be connected.

2 Selection of External Device

Select the External Device to be connected to the Display.

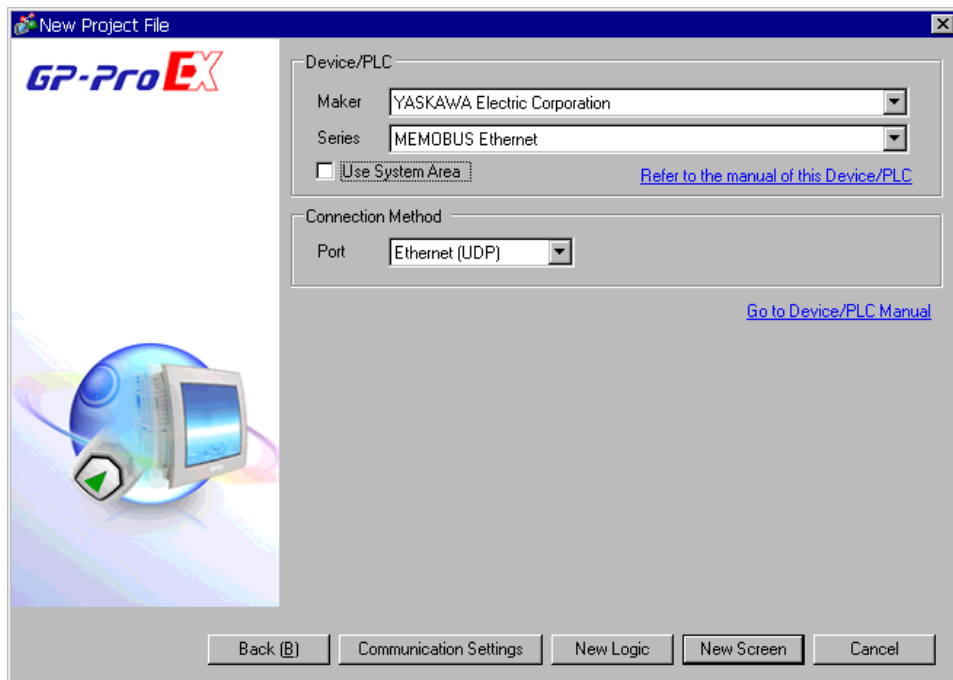

Setup Items	Setup Description
Maker	Select the maker of the External Device to be connected. Select "YASKAWA Electric Corporation".
Driver	Select a model (series) of the External Device to be connected and connection method. Select "MEMOBUS Ethernet". Check the External Device which can be connected in "MEMOBUS Ethernet" in system configuration. ☞ "1 System Configuration" (page 3)
Use System Area	Check this option to synchronize the system data area of the Display and the device (memory) of the External Device. When synchronized, you can use the External Device's ladder program to switch the display or display the window on the Display. Cf. GP-Pro EX Reference Manual "LS Area (Direct Access Method Area)" This feature can also be set in GP-Pro EX or in the Display's offline mode. Cf. GP-Pro EX Reference Manual "Display Unit (System Area) Settings Guide" Cf. Maintenance/Troubleshooting Guide "Main Unit - System Area Settings"
Port	Select the Display port to be connected to the External Device.

3 Example of Communication Setting

Examples of communication settings of the Display and the External Device, recommended by Pro-face, are shown.

3.1 Setting Example 1

■ Settings of GP-Pro EX

◆ Communication Settings

To display the setting screen, select [Device/PLC Settings] from [System setting window] in workspace.

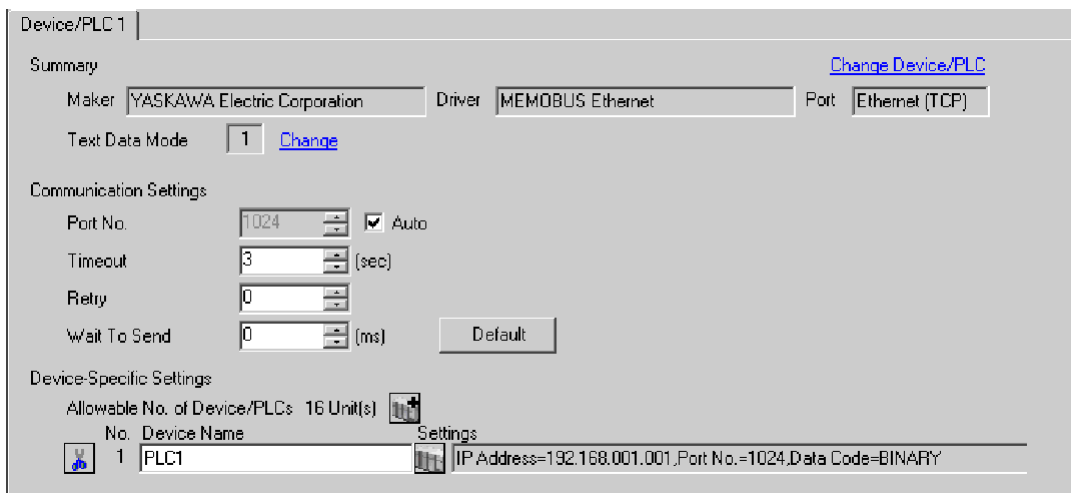

◆ Device Setting

To display the setting screen, click  ([Setting]) of External Device you want to set from [Device-Specific Settings] of [Device/PLC Settings].

When you connect multiple External Device, click  from [Device-Specific Settings] of [Device/PLC Settings] to add another External Device.

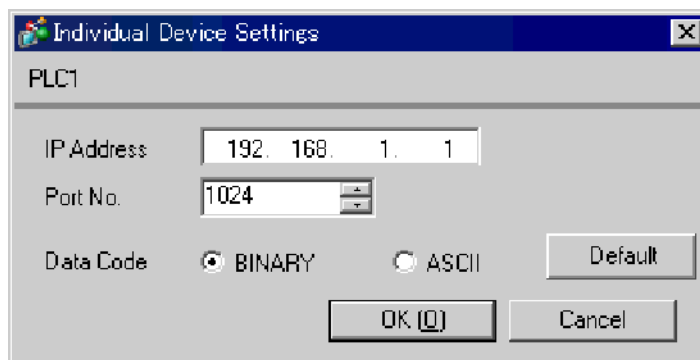

◆ Notes

- Check with a network administrator about IP address. Do not set the duplicate IP address.
- Set IP address on the External Device for IP address in Device-specific settings.
- You need to set IP address on the display in the offline mode of the display.

■ Settings of External Device

Communication setting of communication module 218IF by ladder software. (Check the operation in MPE720 Version5.32)

◆ Ladder Software Setting

1 Start ladder software, make an order folder and a PLC folder in a root folder.

Select the connected PLC at the time of PLC folder making.

2 Click the right button of the PLC which select logon in the displayed menu.

NOTE

- Logon after confirming that a check does not begin [online] of a displayed menu.
- Refer to User's Manual of the PLC about a method of logon.

3 Double-click the [Definition folder]-[Module constitution] of the PLC folder, and display [Engineering Manager].

4 Select the rack classification and link I/F, the pull-down menu in [Controller] of [Engineering Manager].

Set the number corresponding to the slot number that a communication module uses.

Select the communication module, setting contents are displayed to [Module details] of [Engineering Manager].

5 Double-click the number part at No. in [Module details].

Double-click the slot number connecting the ethernet unit.

Setup Items		Setup Description
Transmission parameter	This Station IP address	PLC IP address
Connection parameter	My Port	PLC port No.
	DST. IP Address ^{*1}	GP-Pro EX IP address
	DST. Port ^{*1}	GP-Pro EX port No.
	Connection type	TCP
	Protocol type	expansion memobus
	Code	BIN

*1 When you check the [Auto] of a port number in the communication setting of the GP-Pro EX, set the IP address and the port number to "0.0.0.0" and "00000", respectively.

6 Double-click the "No.00", and set serial communication.

Use serial communication setting to forward communication setting and the ladder program to the PLC.

7 Save setting content and finish [Engineering Manager].

8 Make the communication ladder "high speed drawing".

 "◆ Ladder Program for Communication" (page 8)

9 Turn the DIP switch "INIT" of a communication module to ON, and supply the power.

10 Forward communication setting and a ladder program to a communication module.

11 Log on the PLC in online and write the transferred data to the flash memory.

12 Turn the PLC power and the INIT DIP switch to OFF. Then, turn the PLC power to ON.

◆ Notes

- Check with a network administrator about IP address. Do not set the duplicate IP address.
- Please refer to the manual of the ladder software for more detail.

◆ Ladder Program for Communication

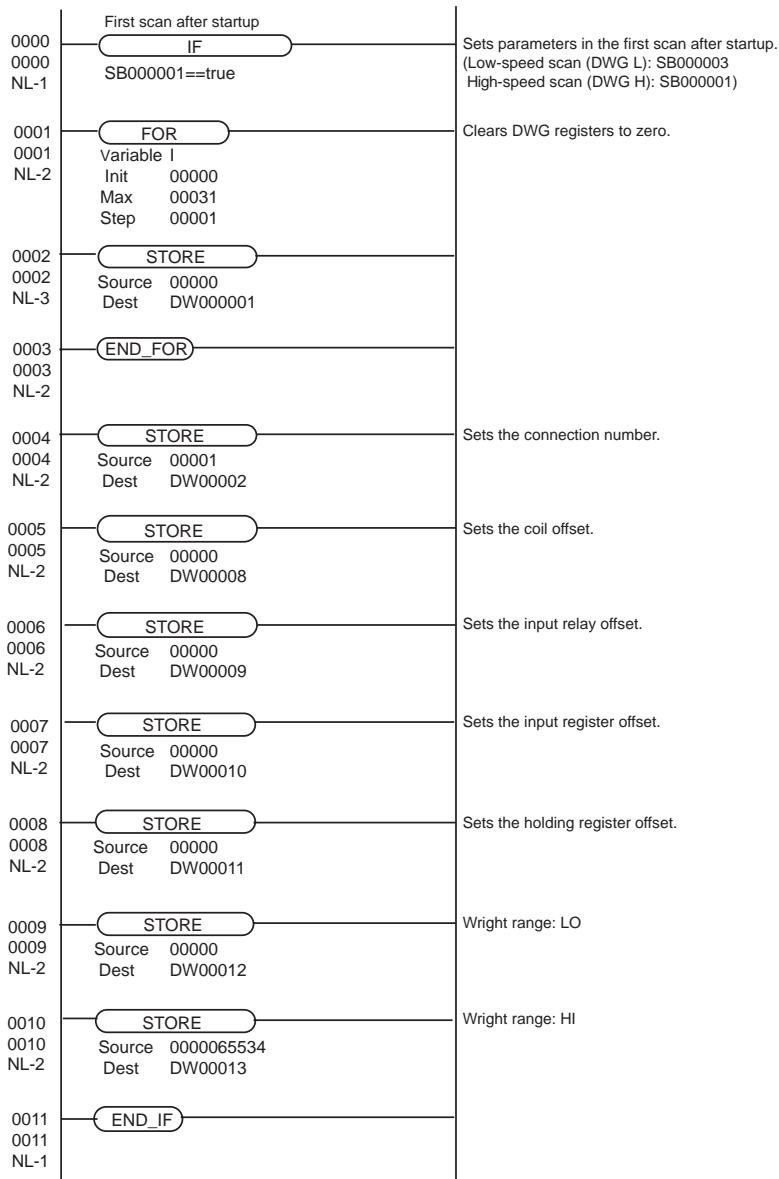

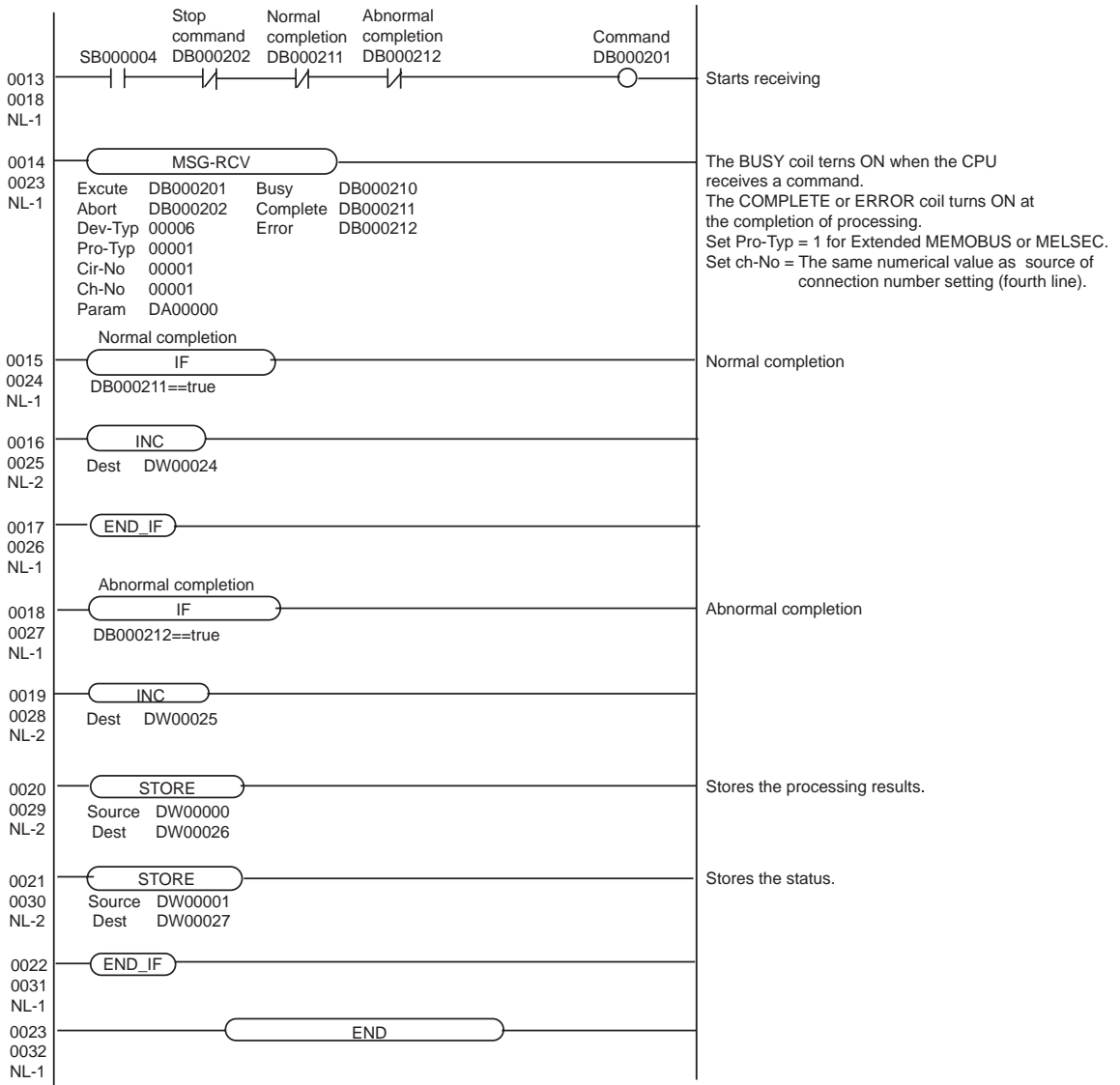

3.2 Setting Example 2

■ Settings of GP-Pro EX

◆ Communication Settings

To display the setting screen, select [Device/PLC Settings] from [System setting window] in workspace.

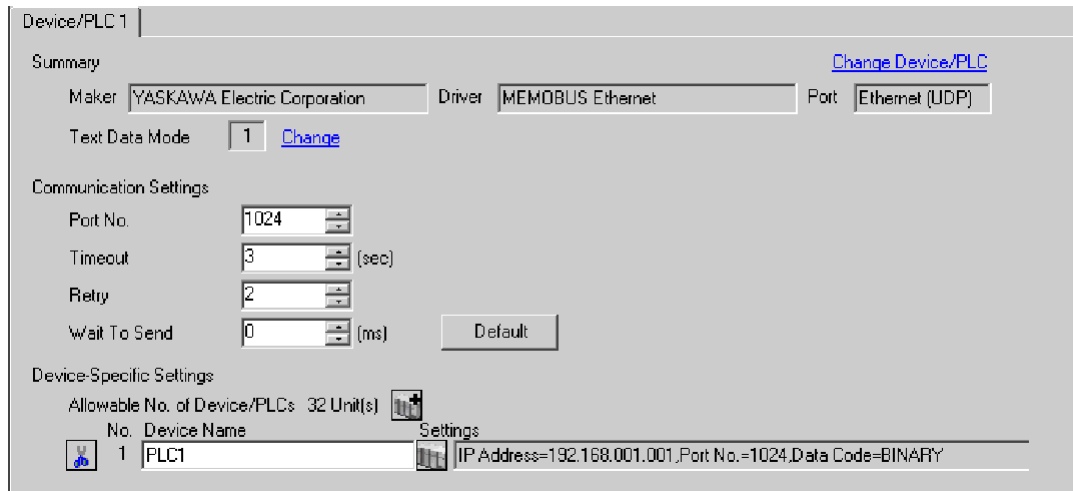

◆ Device Setting

To display the setting screen, click  ([Setting]) of External Device you want to set from [Device-Specific Settings] of [Device/PLC Settings].

When you connect multiple External Device, click  from [Device-Specific Settings] of [Device/PLC Settings] to add another External Device.

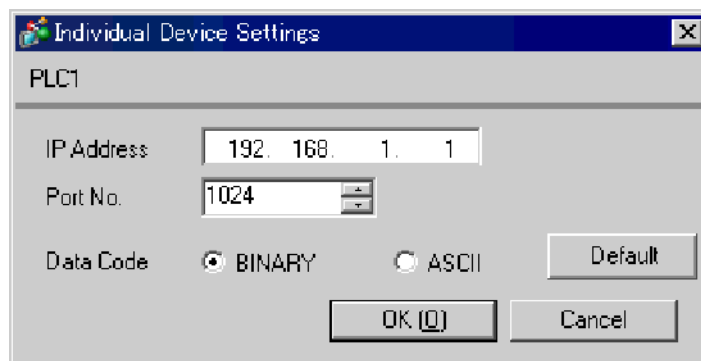

◆ Notes

- Check with a network administrator about IP address. Do not set the duplicate IP address.
- Set IP address on the External Device for IP address in Device-specific settings.
- You need to set IP address on the display in the offline mode of the display.

■ Settings of External Device

Communication setting of communication module 218IF by ladder software. (Check the operation in MPE720 Version5.32)

◆ Ladder Software Setting

1 Start ladder software, make an order folder and a PLC folder in a root folder.

Select the connected PLC at the time of PLC folder making.

2 Click the right button of the PLC which select logon in the displayed menu.

NOTE

- Logon after confirming that a check does not begin [online] of a displayed menu.
- Refer to User's Manual of the PLC about a method of logon.

3 Double-click the [Definition folder]-[Module constitution] of the PLC folder, and display [Engineering Manager].

4 Select the rack classification and link I/F, the pull-down menu in [Controller] of [Engineering Manager].

Set the number corresponding to the slot number that a communication module uses.

Select the communication module, setting contents are displayed to [Module details] of [Engineering Manager].

5 Double-click the number part at No. in [Module details].

Double-click the slot number connecting the ethernet unit.

Setup Items		Setup Description
Transmission parameter	This Station IP address	PLC IP address
Connection parameter	My Port	PLC port No.
	DST. IP Address	GP-Pro EX IP address
	DST. Port	GP-Pro EX port No.
	Connection type	UDP
	Protocol type	expansion memobus
	Code	BIN

6 Double-click the "No.00", and set serial communication.

Use serial communication setting to forward communication setting and the ladder program to the PLC.

7 Save setting content and finish [Engineering Manager].

8 Make the communication ladder "high speed drawing".

 "◆ Ladder Program for Communication" (page 12)

9 Turn the DIP switch "INIT" of a communication module to ON, and supply the power.

10 Forward communication setting and a ladder program to a communication module.

11 Log on the PLC in online and write the transferred data to the flash memory.

12 Turn the PLC power and the INIT DIP switch to OFF. Then, turn the PLC power to ON.

◆ Notes

- Check with a network administrator about IP address. Do not set the duplicate IP address.
- Please refer to the manual of the ladder software for more detail.

◆ Ladder Program for Communication

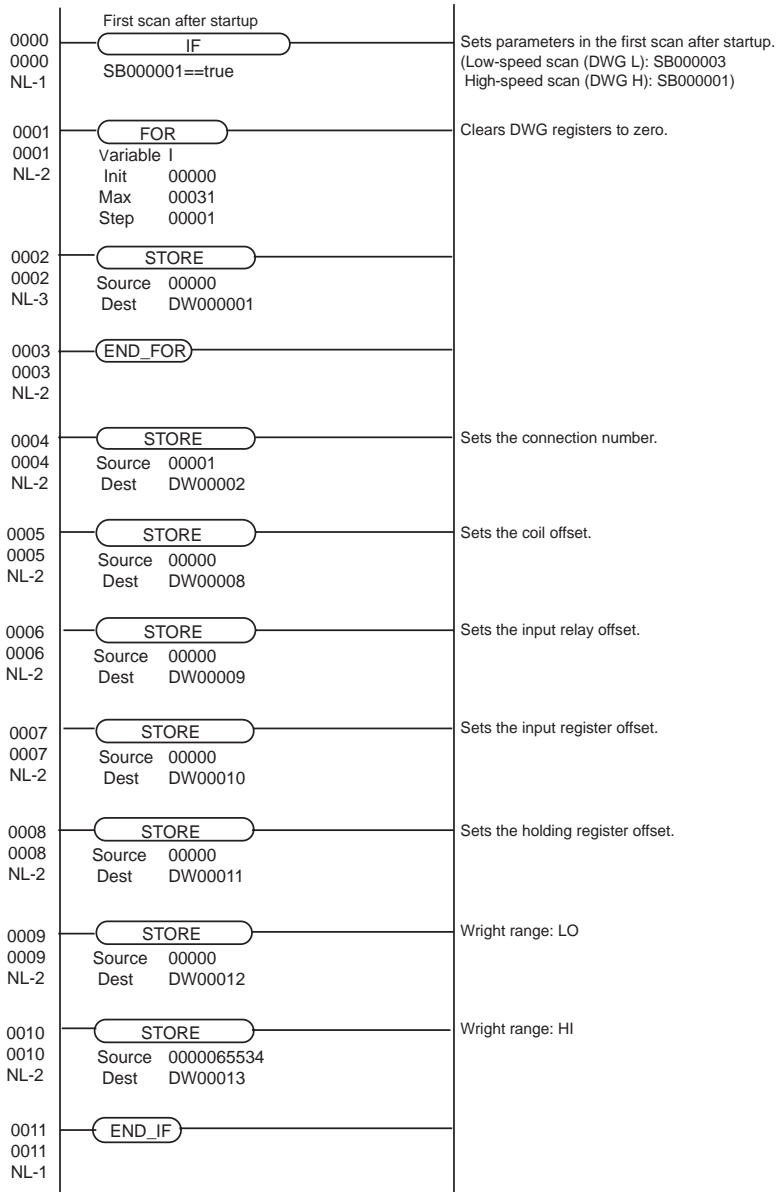

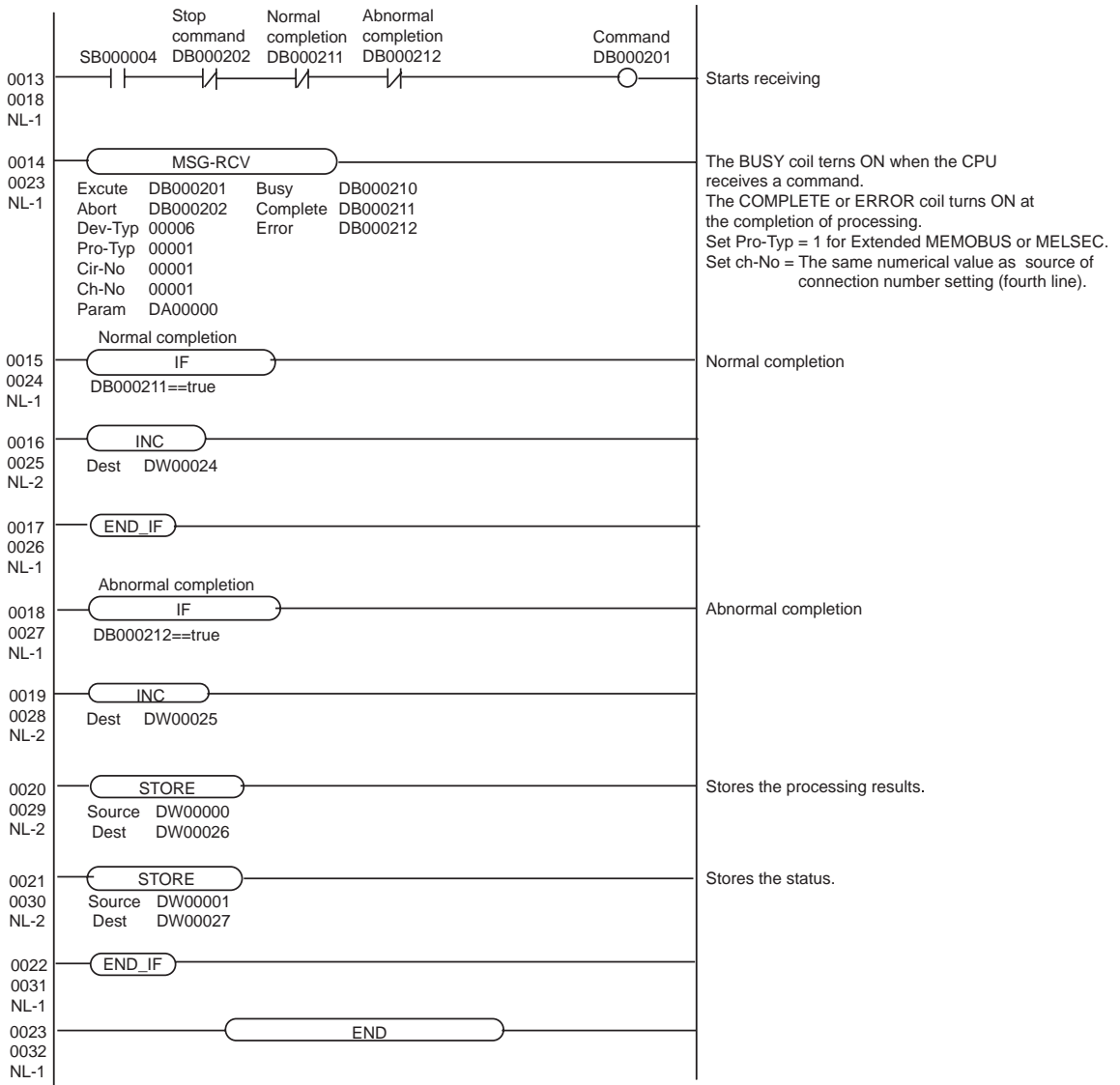

3.3 Setting Example 3

■ Settings of GP-Pro EX

◆ Communication Settings

To display the setting screen, select [Device/PLC Settings] from [System setting window] in workspace.

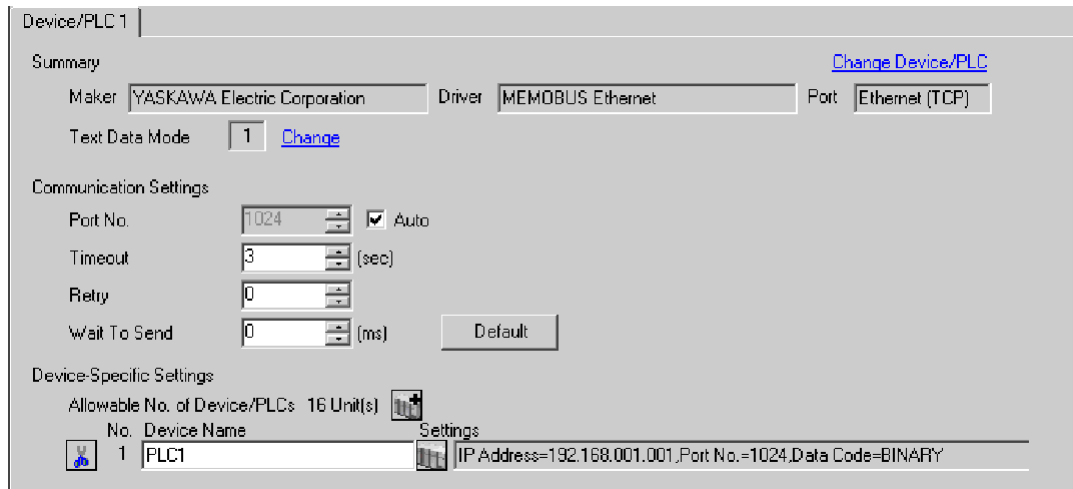

◆ Device Setting

To display the setting screen, click ([Setting]) of External Device you want to set from [Device-Specific Settings] of [Device/PLC Settings].

When you connect multiple External Device, click from [Device-Specific Settings] of [Device/PLC Settings] to add another External Device.

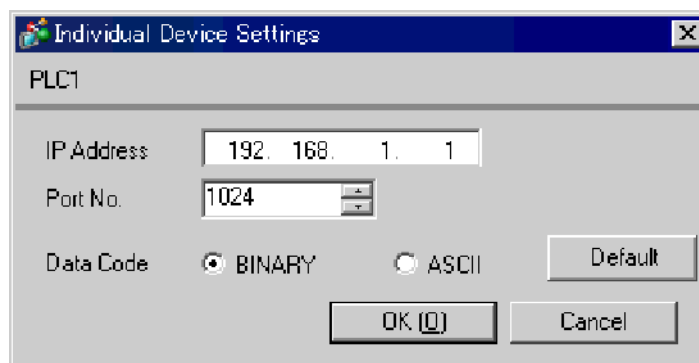

◆ Notes

- Check with a network administrator about IP address. Do not set the duplicate IP address.
- Set IP address on the External Device for IP address in Device-specific settings.
- You need to set IP address on the display in the offline mode of the display.

■ Settings of External Device

Communication setting of communication module 218IF-01 by ladder software. (Check the operation in MPE720 Ver.5.32)

◆ Ladder Software Setting

1 Start ladder software, make an order folder and a PLC folder in a root folder.

Select the connected PLC at the time of PLC folder making.

2 Click the right button of the PLC which select logon in the displayed menu.

NOTE

- Logon after confirming that a check does not begin [online] of a displayed menu.
- Refer to User's Manual of the PLC about a method of logon.

3 Double-click the [Definition folder]-[Module constitution] of the PLC folder, and display [Engineering Manager].

4 Select the rack classification and link I/F, the pull-down menu in [Controller] of [Engineering Manager].

Set the number corresponding to the slot number that a communication module uses.

Select the communication module, setting contents are displayed to [Module details] of [Engineering Manager].

5 Double-click the number part at No. in [Module details].

Double-click the slot number connecting the ethernet unit.

Setup Items		Setup Description
Transmission parameter	This Station IP address	PLC IP address
Connection parameter	My Port	PLC port No.
	DST. IP Address ^{*1}	GP-Pro EX IP address
	DST. Port ^{*1}	GP-Pro EX port No.
	Connection type	TCP
	Protocol type	expansion memobus
	Code	BIN

*1 When you check the [Auto] of a port number in the communication setting of the GP-Pro EX, set the IP address and the port number to "0.0.0.0" and "00000", respectively.

6 Double-click the "No.1", and set serial communication.

Use serial communication setting to forward communication setting and the ladder program to the PLC.

7 Save setting content and finish [Engineering Manager].

8 Make the communication ladder "high speed drawing" where "6" is set for [Dev-Typ].

 "◆ Ladder Program for Communication" (page 16)

9 Turn the DIP switch "INIT" of a communication module to ON, and supply the power.

10 Forward communication setting and a ladder program to a communication module.

11 Log on the PLC in online and write the transferred data to the flash memory.

12 Turn the PLC power and the INIT DIP switch to OFF. Then, turn the PLC power to ON.

◆ Notes

- Check with a network administrator about IP address. Do not set the duplicate IP address.
- Please refer to the manual of the ladder software for more detail.

◆ Ladder Program for Communication

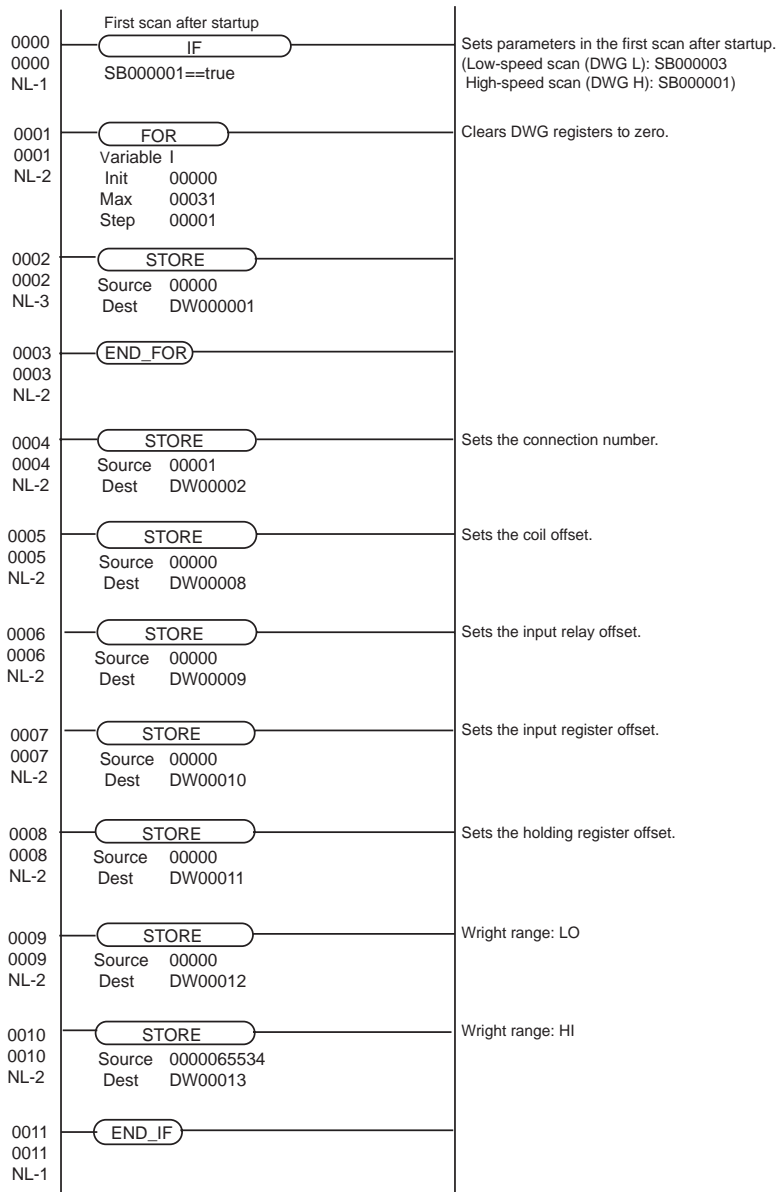

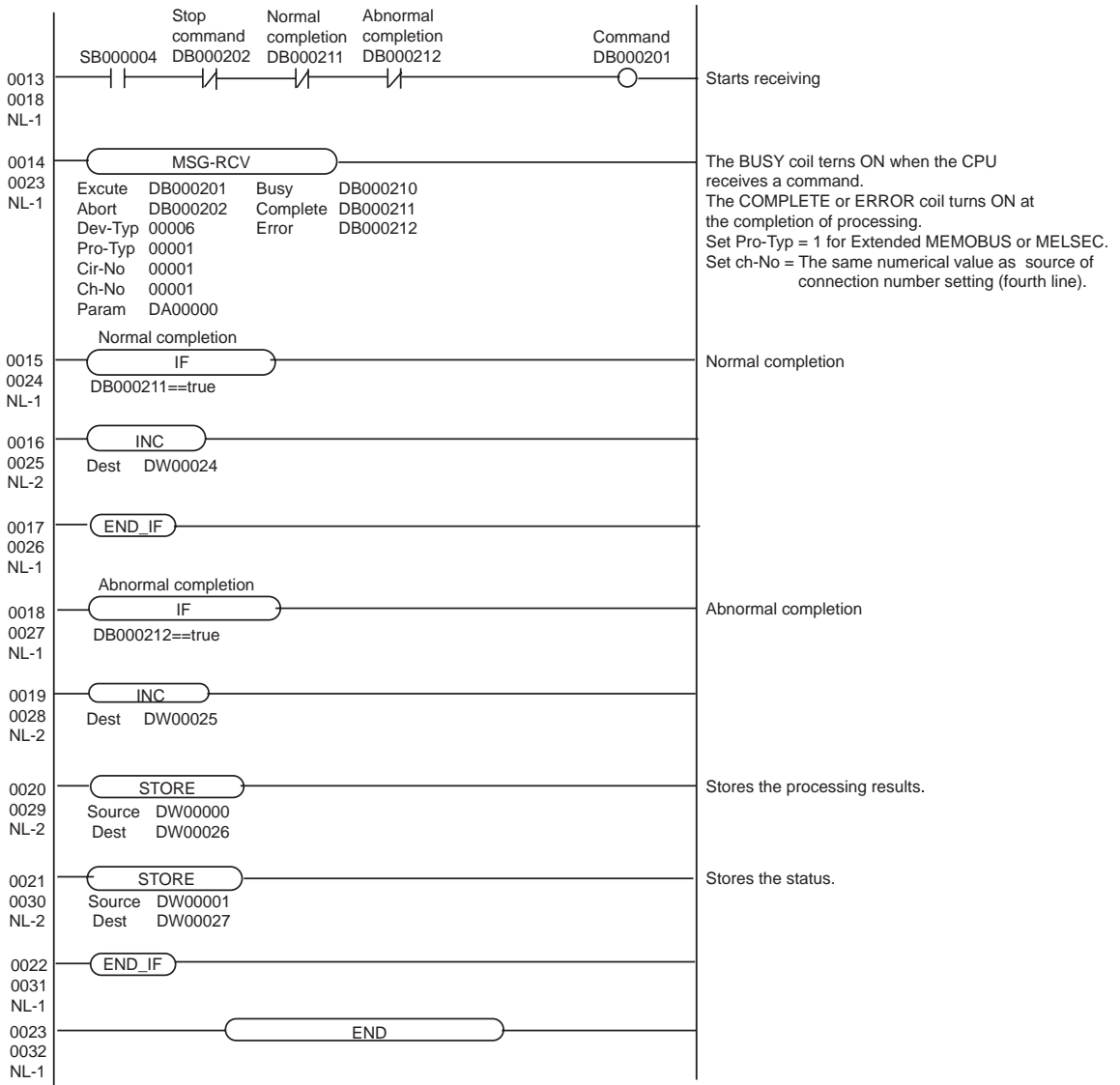

3.4 Setting Example 4

■ Settings of GP-Pro EX

◆ Communication Settings

To display the setting screen, select [Device/PLC Settings] from [System setting window] in workspace.

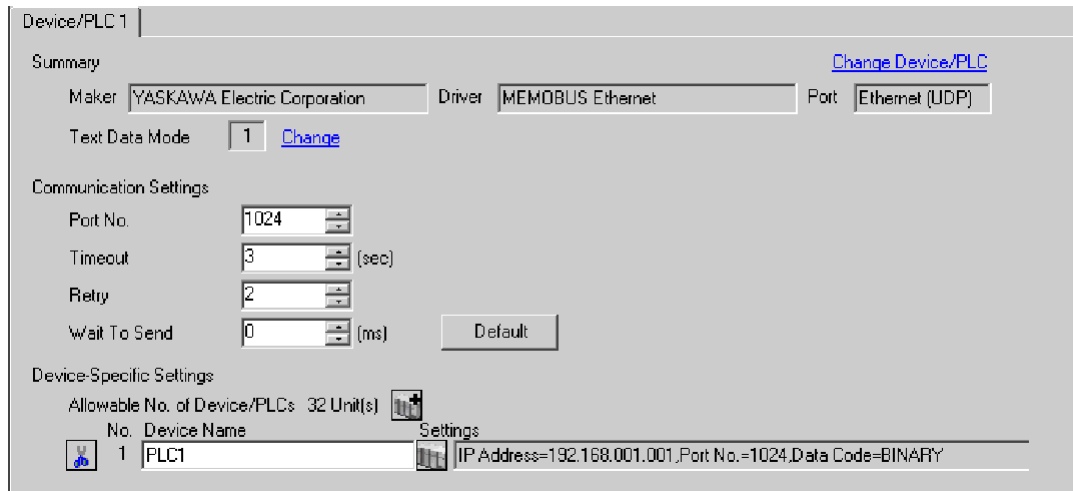

◆ Device Setting

To display the setting screen, click  ([Setting]) of External Device you want to set from [Device-Specific Settings] of [Device/PLC Settings].

When you connect multiple External Device, click  from [Device-Specific Settings] of [Device/PLC Settings] to add another External Device.

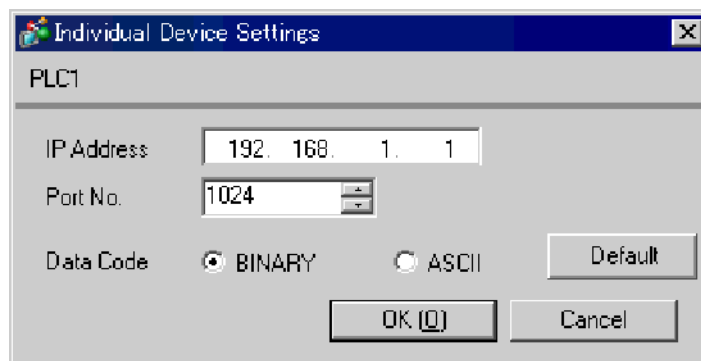

◆ Notes

- Check with a network administrator about IP address. Do not set the duplicate IP address.
- Set IP address on the External Device for IP address in Device-specific settings.
- You need to set IP address on the display in the offline mode of the display.

■ Settings of External Device

Communication setting of communication module 218IF-01 by ladder software. (Check the operation in MPE720 Ver.5.32)

◆ Ladder Software Setting

1 Start ladder software, make an order folder and a PLC folder in a root folder.

Select the connected PLC at the time of PLC folder making.

2 Click the right button of the PLC which select logon in the displayed menu.

NOTE

- Logon after confirming that a check does not begin [online] of a displayed menu.
- Refer to User's Manual of the PLC about a method of logon.

3 Double-click the [Definition folder]-[Module constitution] of the PLC folder, and display [Engineering Manager].

4 Select the rack classification and link I/F, the pull-down menu in [Controller] of [Engineering Manager].

Set the number corresponding to the slot number that a communication module uses.

Select the communication module, setting contents are displayed to [Module details] of [Engineering Manager].

5 Double-click the number part at No. in [Module details].

Double-click the slot number connecting the ethernet unit.

Setup Items		Setup Description
Transmission parameter	This Station IP address	PLC IP address
Connection parameter	My Port	PLC port No.
	DST. IP Address	GP-Pro EX IP address
	DST. Port	GP-Pro EX port No.
	Connection type	UDP
	Protocol type	expansion memobus
	Code	BIN

6 Double-click the "No.1", and set serial communication.

Use serial communication setting to forward communication setting and the ladder program to the PLC.

7 Save setting content and finish [Engineering Manager].

8 Make the communication ladder "high speed drawing" where "6" is set for [Dev-Typ].

 " ◆ Ladder Program for Communication" (page 20)

9 Turn the DIP switch "INIT" of a communication module to ON, and supply the power.

10 Forward communication setting and a ladder program to a communication module.

11 Log on the PLC in online and write the transferred data to the flash memory.

12 Turn the PLC power and the INIT DIP switch to OFF. Then, turn the PLC power to ON.

◆ Notes

- Check with a network administrator about IP address. Do not set the duplicate IP address.
- Please refer to the manual of the ladder software for more detail.

◆ Ladder Program for Communication

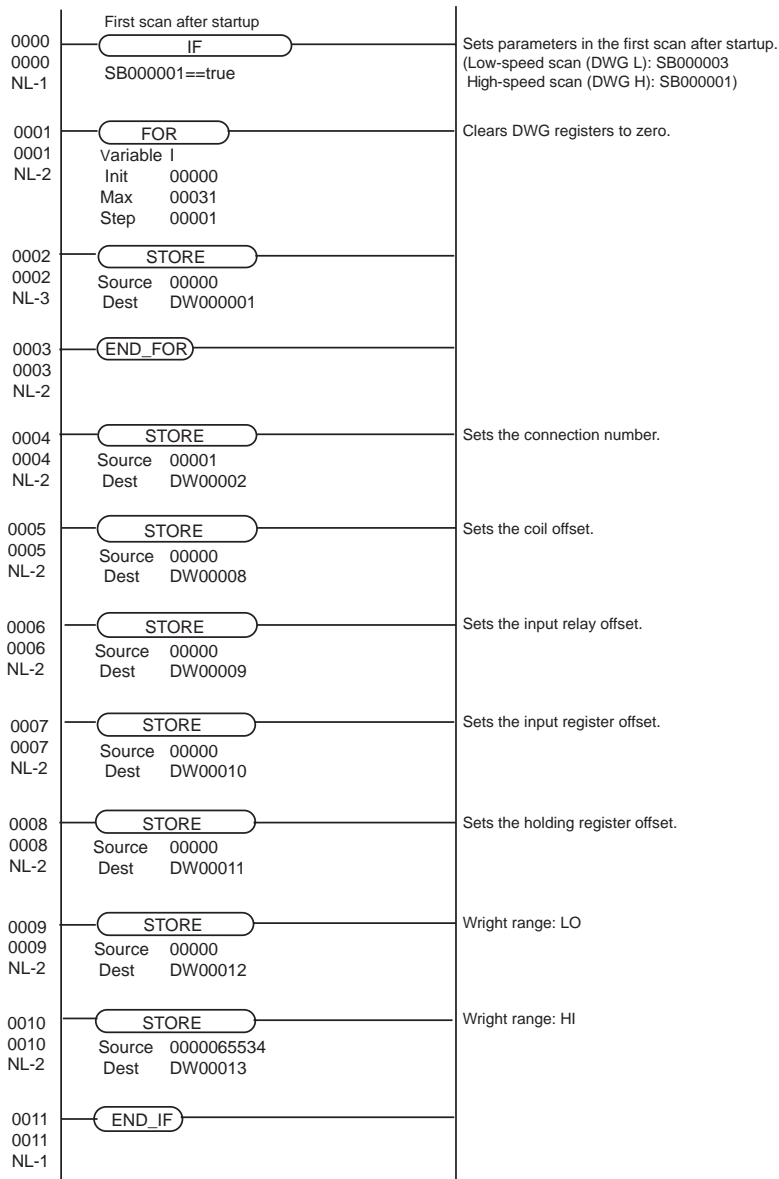

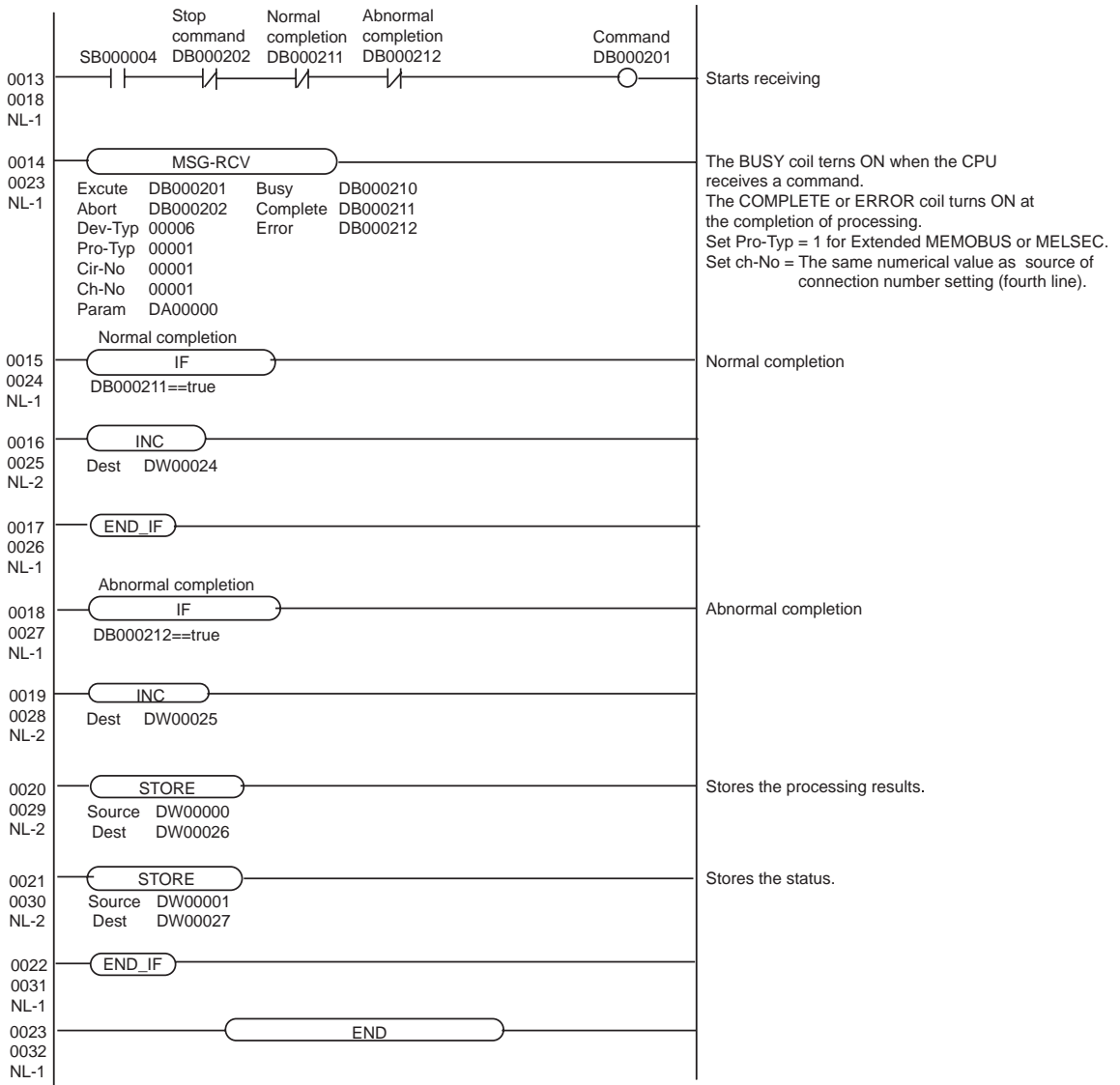

3.5 Setting Example 5

■ Settings of GP-Pro EX

◆ Communication Settings

To display the setting screen, select [Device/PLC Settings] from [System setting window] in workspace.

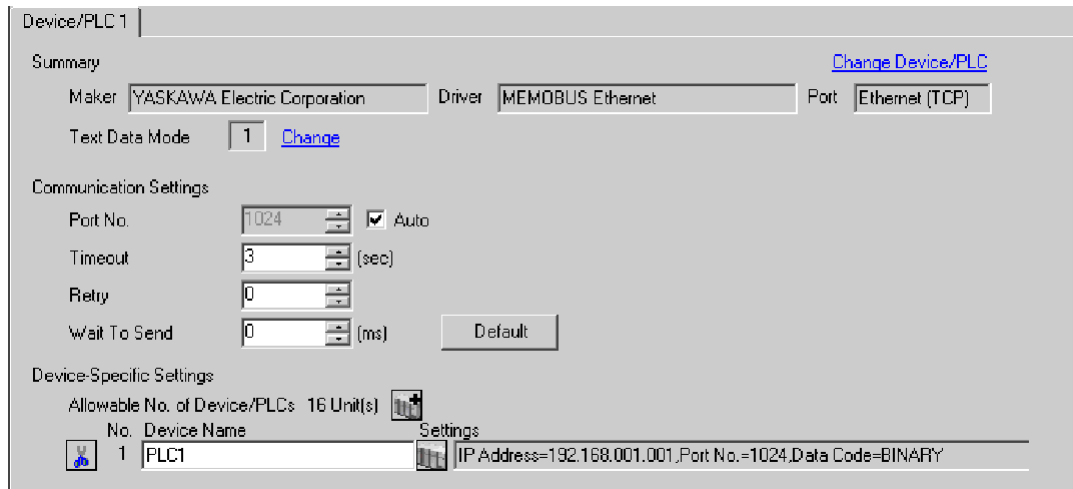

◆ Device Setting

To display the setting screen, click  ([Setting]) of External Device you want to set from [Device-Specific Settings] of [Device/PLC Settings].

When you connect multiple External Device, click  from [Device-Specific Settings] of [Device/PLC Settings] to add another External Device.

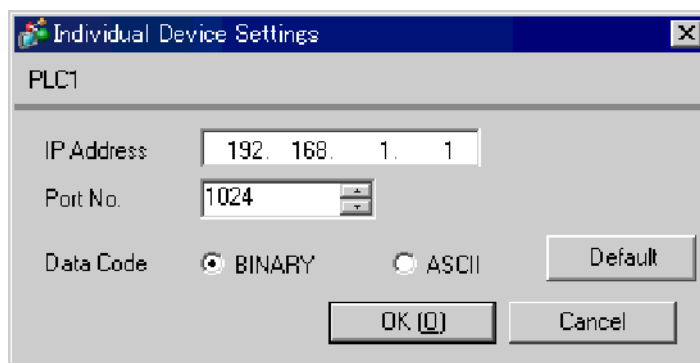

◆ Notes

- Check with a network administrator about IP address. Do not set the duplicate IP address.
- Set IP address on the External Device for IP address in Device-specific settings.
- You need to set IP address on the display in the offline mode of the display.

■ Settings of External Device

Communication setting of communication module CPU unit by ladder software. (Check the operation in MPE720 Ver.6)

◆ Ladder Software Setting

1 Start ladder software, make an order folder and a PLC folder in a root folder.

Select the connected PLC at the time of PLC folder making.

2 Click the right button of the PLC which select logon in the displayed menu.

NOTE

- Logon after confirming that a check does not begin [online] of a displayed menu.
- Refer to User's Manual of the PLC about a method of logon.

3 Double-click the [Definition folder]-[Module constitution] of the PLC folder, and display [Engineering Manager].

4 Select the rack classification and link I/F, the pull-down menu in [Controller] of [Engineering Manager].

Set the number corresponding to the slot number that a communication module uses.

Select the communication module, setting contents are displayed to [Module details] of [Engineering Manager].

5 Double-click the number part at No. in [Module details].

Double-click the slot number connecting the ethernet unit.

6 Select [Transmission Parameters] tab, and set the setup items as follows.

Setup Items	Setting Value
IP Address	192.168.1.2
Subnet Mask	255.255.255.0

7 Click [Easy Setting] in [Transmission Parameters] tab to display [Message Communication Easy Setting] dialog box.

8 Set the setup items as follows, and click [OK].

Setup Items	Setting Value
Connection No.	1
MP Series Port No.	1024
Communication protocol Type	Extended MEMOBUS
Connect Type	TCP
Code	BIN
Node Port IP Address ^{*1}	192.168.1.1
Other Device Port No. ^{*1}	1024

*1 Set the IP address and the port number of the Display.
When you check the [Auto] of a port number in the communication setting of the GP-Pro EX, set the IP address and the port number to "0.0.0.0" and "00000", respectively.

9 Double-click [Setting] to display [Automatically Reception Setting] dialog box.

10 Select "Enable" of [Automatically Reception], and click [OK].

11 Turn the DIP switch "INIT" of a communication module to ON, and supply the power.

12 Forward communication setting and a ladder program to a communication module.

13 Log on the PLC in online and write the transferred data to the flash memory.

14 Turn the PLC power and the INIT DIP switch to OFF. Then, turn the PLC power to ON.

◆ Notes

- Check with a network administrator about IP address. Do not set the duplicate IP address.
- Please refer to the manual of the ladder software for more detail.
- When Automatically Reception is disabled for messages, the ladder program for communication is required.

◆ Ladder Program for Communication

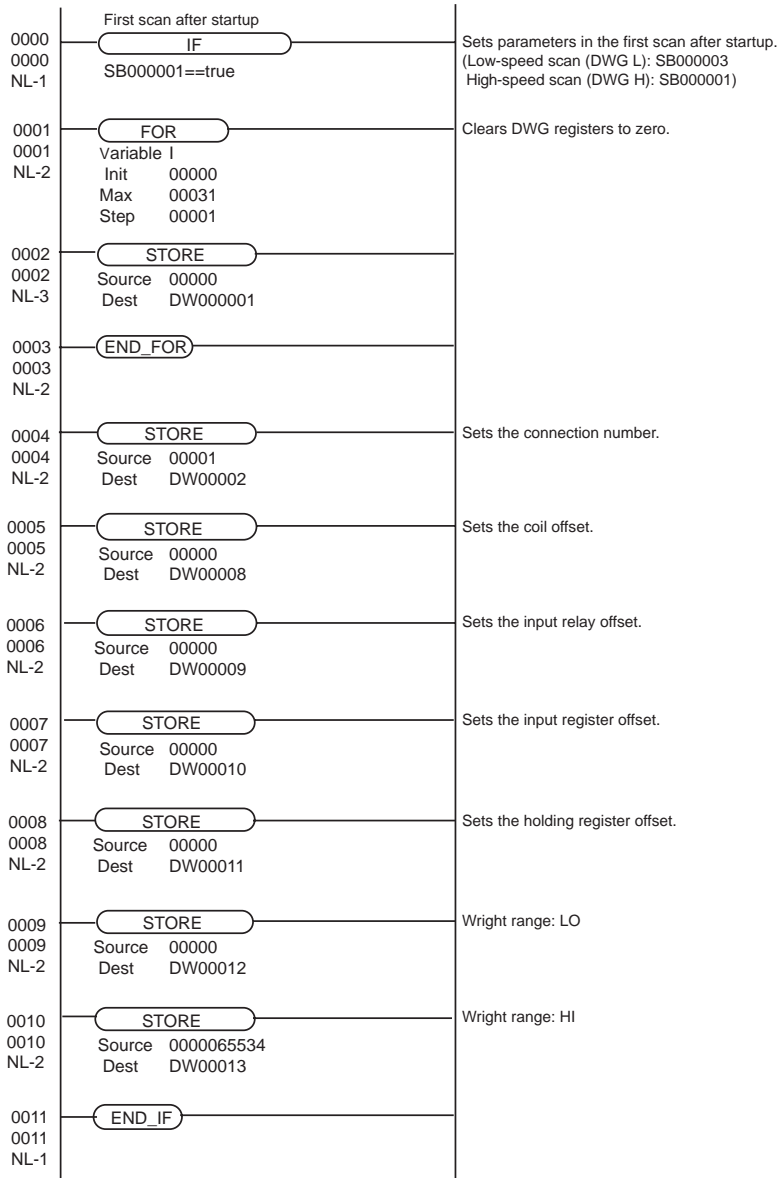

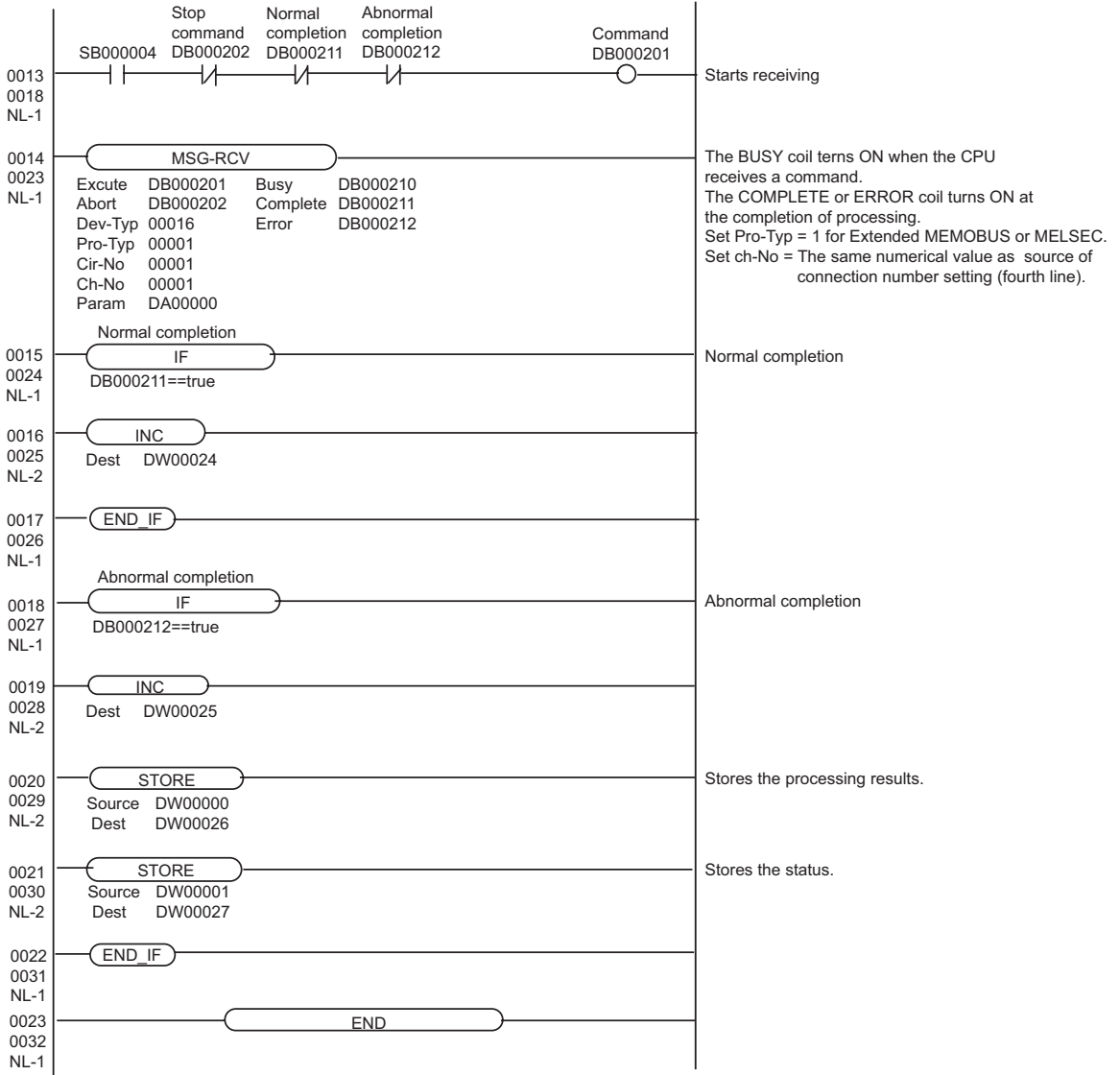

3.6 Setting Example 6

■ Settings of GP-Pro EX

◆ Communication Settings

To display the setting screen, select [Device/PLC Settings] from [System setting window] in workspace.

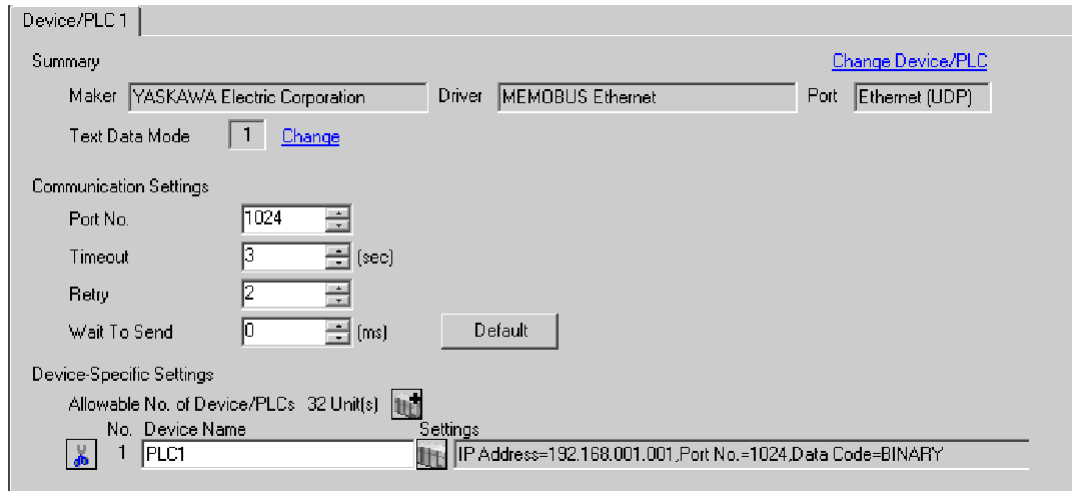

◆ Device Setting

To display the setting screen, click  ([Setting]) of External Device you want to set from [Device-Specific Settings] of [Device/PLC Settings].

When you connect multiple External Device, click  from [Device-Specific Settings] of [Device/PLC Settings] to add another External Device.

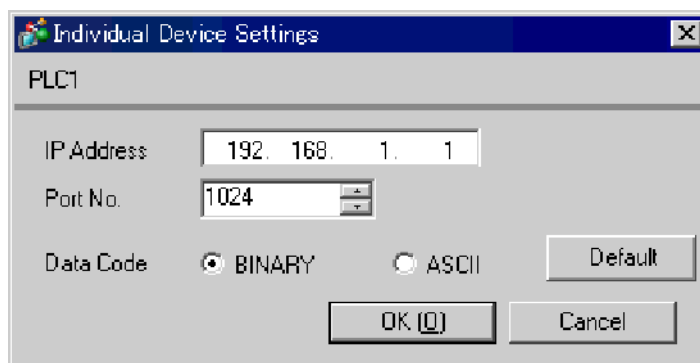

◆ Notes

- Check with a network administrator about IP address. Do not set the duplicate IP address.
- Set IP address on the External Device for IP address in Device-specific settings.
- You need to set IP address on the display in the offline mode of the display.

■ Settings of External Device

Communication setting of communication module CPU unit by ladder software. (Check the operation in MPE720 Ver.6)

◆ Ladder Software Setting

1 Start ladder software, make an order folder and a PLC folder in a root folder.

Select the connected PLC at the time of PLC folder making.

2 Click the right button of the PLC which select logon in the displayed menu.

NOTE

- Logon after confirming that a check does not begin [online] of a displayed menu.
- Refer to User's Manual of the PLC about a method of logon.

3 Double-click the [Definition folder]-[Module constitution] of the PLC folder, and display [Engineering Manager].

4 Select the rack classification and link I/F, the pull-down menu in [Controller] of [Engineering Manager].

Set the number corresponding to the slot number that a communication module uses.

Select the communication module, setting contents are displayed to [Module details] of [Engineering Manager].

5 Double-click the number part at No. in [Module details].

Double-click the slot number connecting the ethernet unit.

6 Select [Transmission Parameters] tab, and set the setup items as follows.

Setup Items	Setting Value
IP Address	192.168.1.2
Subnet Mask	255.255.255.0

7 Click [Easy Setting] in [Transmission Parameters] tab to display [Message Communication Easy Setting] dialog box.

8 Set the setup items as follows, and click [OK].

Setup Items	Setting Value
Connection No.	1
MP Series Port No.	1024
Communication protocol Type	Extended MEMOBUS
Connect Type	UDP
Code	BIN
Node Port IP Address ^{*1}	192.168.1.1
Other Device Port No. ^{*1}	1024

*1 Set the IP address and the port number of the Display.

9 Double-click [Setting] to display [Automatically Reception Setting] dialog box.

10 Select "Enable" of [Automatically Reception], and click [OK].

11 Turn the DIP switch "INIT" of a communication module to ON, and supply the power.

12 Forward communication setting and a ladder program to a communication module.

13 Log on the PLC in online and write the transferred data to the flash memory.

14 Turn the PLC power and the INIT DIP switch to OFF. Then, turn the PLC power to ON.

◆ Notes

- Check with a network administrator about IP address. Do not set the duplicate IP address.
- Please refer to the manual of the ladder software for more detail.
- When Automatically Reception is disabled for messages, the ladder program for communication is required.

◆ Ladder Program for Communication

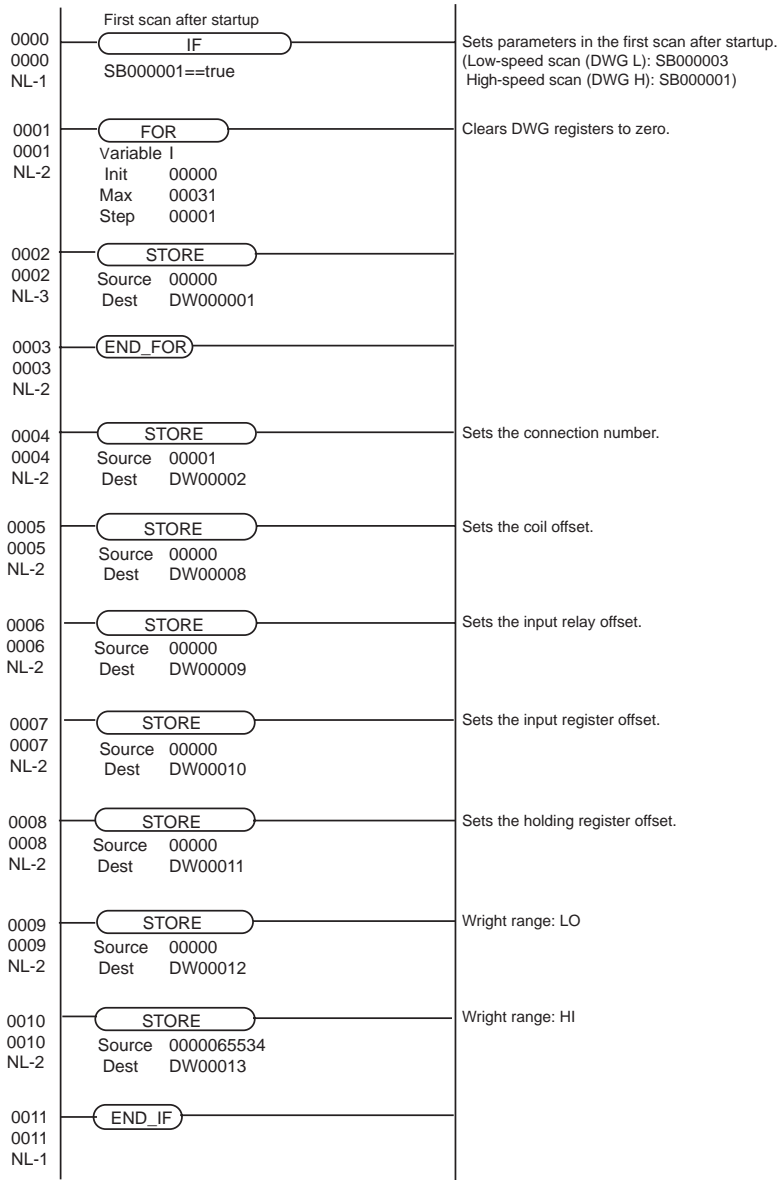

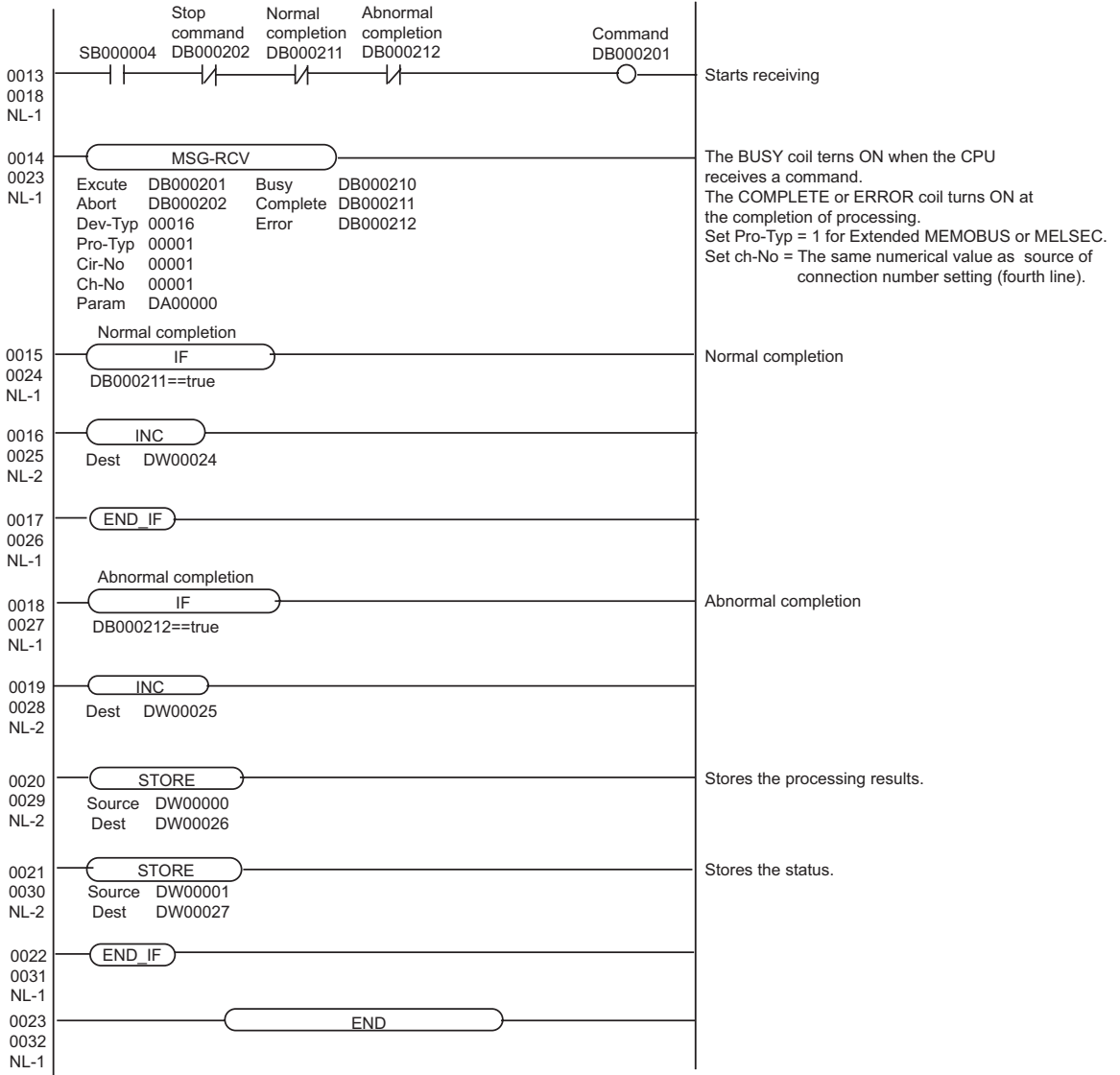

3.7 Setting Example 7

■ Settings of GP-Pro EX

◆ Communication Settings

To display the setting screen, select [Device/PLC Settings] from [System setting window] in workspace.

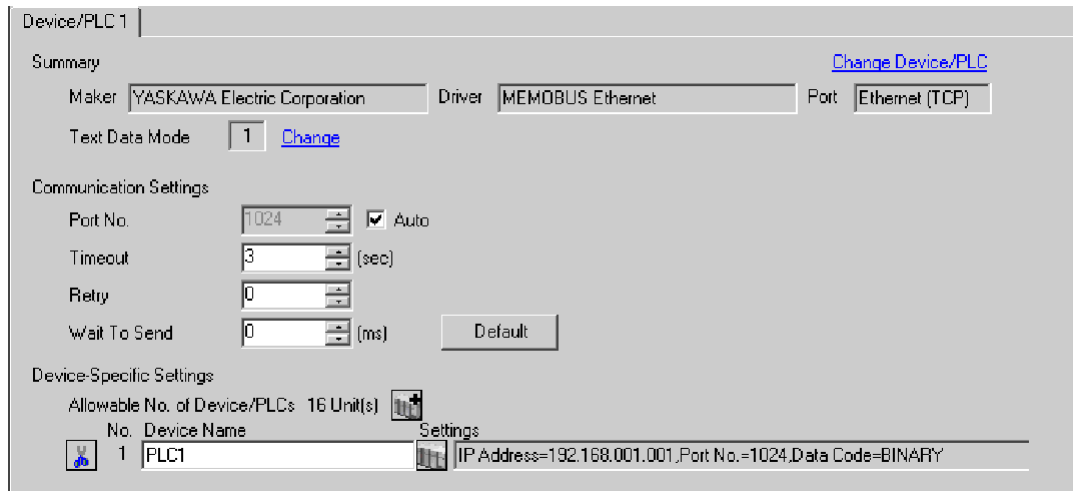

◆ Device Setting

To display the setting screen, click  ([Setting]) of External Device you want to set from [Device-Specific Settings] of [Device/PLC Settings].

When you connect multiple External Device, click  from [Device-Specific Settings] of [Device/PLC Settings] to add another External Device.

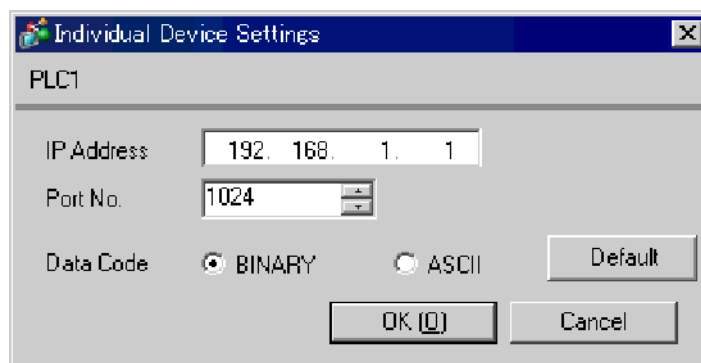

◆ Notes

- Check with a network administrator about IP address. Do not set the duplicate IP address.
- Set IP address on the External Device for IP address in Device-specific settings.
- You need to set IP address on the display in the offline mode of the display.

■ Settings of External Device

Communication setting of communication module 218IF-02 by ladder software. (Check the operation in MPE720 Ver.5.32)

◆ Ladder Software Setting

1 Start ladder software, make an order folder and a PLC folder in a root folder.

Select the connected PLC at the time of PLC folder making.

2 Click the right button of the PLC which select logon in the displayed menu.

NOTE

- Logon after confirming that a check does not begin [online] of a displayed menu.
- Refer to User's Manual of the PLC about a method of logon.

3 Double-click the [Definition folder]-[Module constitution] of the PLC folder, and display [Engineering Manager].

4 Select the rack classification and link I/F, the pull-down menu in [Controller] of [Engineering Manager].

Set the number corresponding to the slot number that a communication module uses.

Select the communication module, setting contents are displayed to [Module details] of [Engineering Manager].

5 Double-click the number part at No. in [Module details].

Double-click the slot number connecting the ethernet unit.

Setup Items		Setup Description
Transmission parameter	This Station IP address	PLC IP address
Connection parameter	My Port	PLC port No.
	DST. IP Address ^{*1}	GP-Pro EX IP address
	DST. Port ^{*1}	GP-Pro EX port No.
	Connection type	TCP
	Protocol type	expansion memobus
	Code	BIN

*1 When you check the [Auto] of a port number in the communication setting of the GP-Pro EX, set the IP address and the port number to "0.0.0.0" and "00000", respectively.

6 Double-click the "No.1", and set serial communication.

Use serial communication setting to forward communication setting and the ladder program to the PLC.

7 Save setting content and finish [Engineering Manager].

8 Make the communication ladder "high speed drawing" where "16" is set for [Dev-Typ].

 "◆ Ladder Program for Communication" (page 32)

9 Turn the DIP switch "INIT" of a communication module to ON, and supply the power.

10 Forward communication setting and a ladder program to a communication module.

11 Log on the PLC in online and write the transferred data to the flash memory.

12 Turn the PLC power and the INIT DIP switch to OFF. Then, turn the PLC power to ON.

◆ Notes

- Check with a network administrator about IP address. Do not set the duplicate IP address.
- Please refer to the manual of the ladder software for more detail.

◆ Ladder Program for Communication

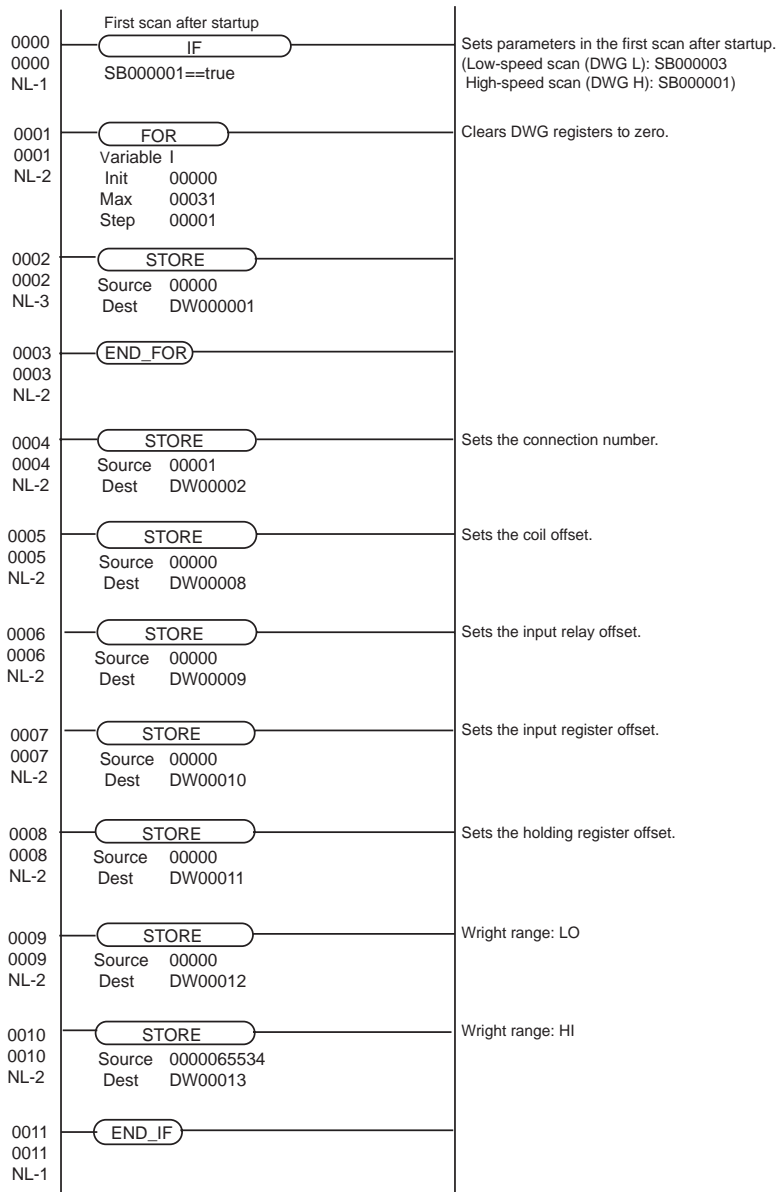

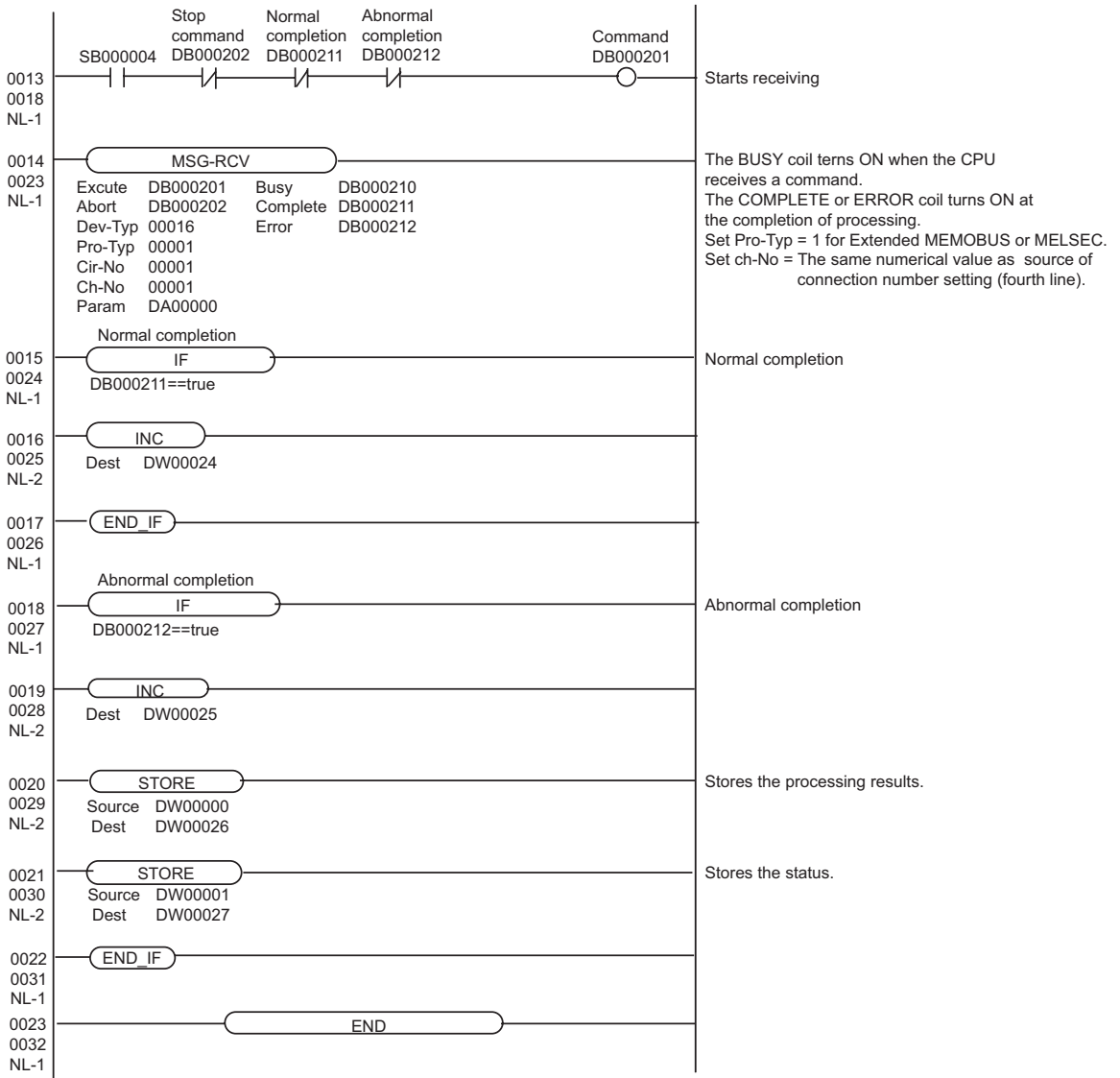

3.8 Setting Example 8

■ Settings of GP-Pro EX

◆ Communication Settings

To display the setting screen, select [Device/PLC Settings] from [System setting window] in workspace.

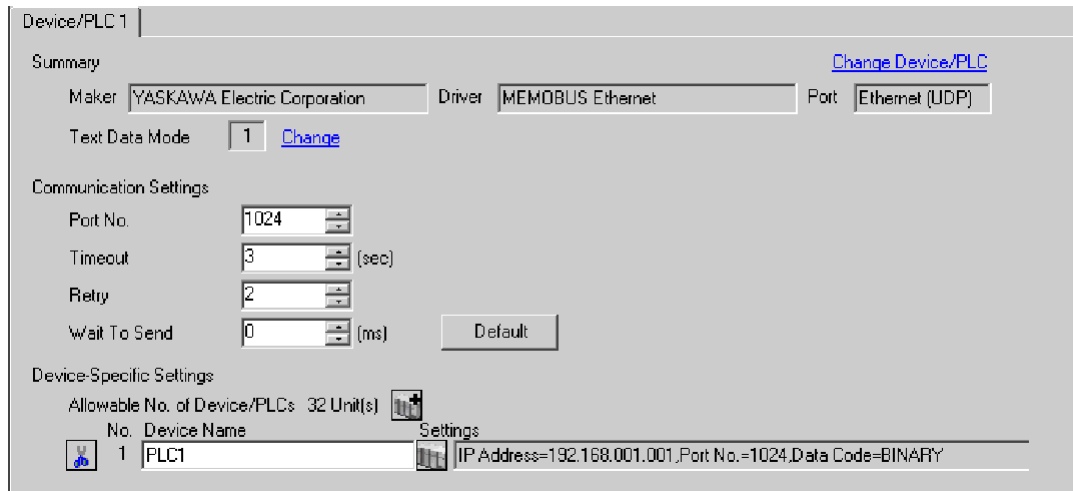

◆ Device Setting

To display the setting screen, click  ([Setting]) of External Device you want to set from [Device-Specific Settings] of [Device/PLC Settings].

When you connect multiple External Device, click  from [Device-Specific Settings] of [Device/PLC Settings] to add another External Device.

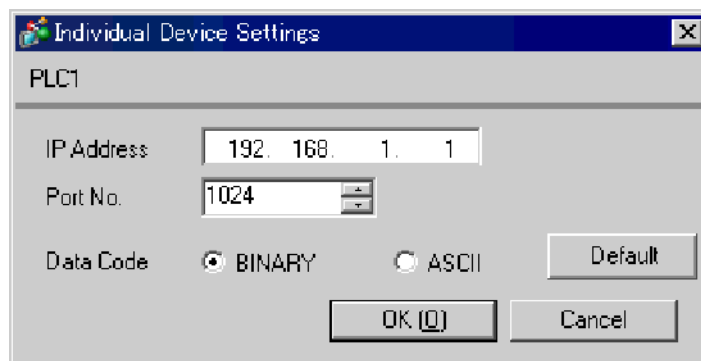

◆ Notes

- Check with a network administrator about IP address. Do not set the duplicate IP address.
- Set IP address on the External Device for IP address in Device-specific settings.
- You need to set IP address on the display in the offline mode of the display.

■ Settings of External Device

Communication setting of communication module 218IF-02 by ladder software. (Check the operation in MPE720 Ver.5.32)

◆ Ladder Software Setting

1 Start ladder software, make an order folder and a PLC folder in a root folder.

Select the connected PLC at the time of PLC folder making.

2 Click the right button of the PLC which select logon in the displayed menu.

NOTE

- Logon after confirming that a check does not begin [online] of a displayed menu.
- Refer to User's Manual of the PLC about a method of logon.

3 Double-click the [Definition folder]-[Module constitution] of the PLC folder, and display [Engineering Manager].

4 Select the rack classification and link I/F, the pull-down menu in [Controller] of [Engineering Manager].

Set the number corresponding to the slot number that a communication module uses.

Select the communication module, setting contents are displayed to [Module details] of [Engineering Manager].

5 Double-click the number part at No. in [Module details].

Double-click the slot number connecting the ethernet unit.

Setup Items		Setup Description
Transmission parameter	This Station IP address	PLC IP address
Connection parameter	My Port	PLC port No.
	DST. IP Address	GP-Pro EX IP address
	DST. Port	GP-Pro EX port No.
	Connection type	UDP
	Protocol type	expansion memobus
	Code	BIN

6 Double-click the "No.1", and set serial communication.

Use serial communication setting to forward communication setting and the ladder program to the PLC.

7 Save setting content and finish [Engineering Manager].

8 Make the communication ladder "high speed drawing" where "16" is set for [Dev-Typ].

 "◆ Ladder Program for Communication" (page 36)

9 Turn the DIP switch "INIT" of a communication module to ON, and supply the power.

10 Forward communication setting and a ladder program to a communication module.

11 Log on the PLC in online and write the transferred data to the flash memory.

12 Turn the PLC power and the INIT DIP switch to OFF. Then, turn the PLC power to ON.

◆ Notes

- Check with a network administrator about IP address. Do not set the duplicate IP address.
- Please refer to the manual of the ladder software for more detail.

◆ Ladder Program for Communication

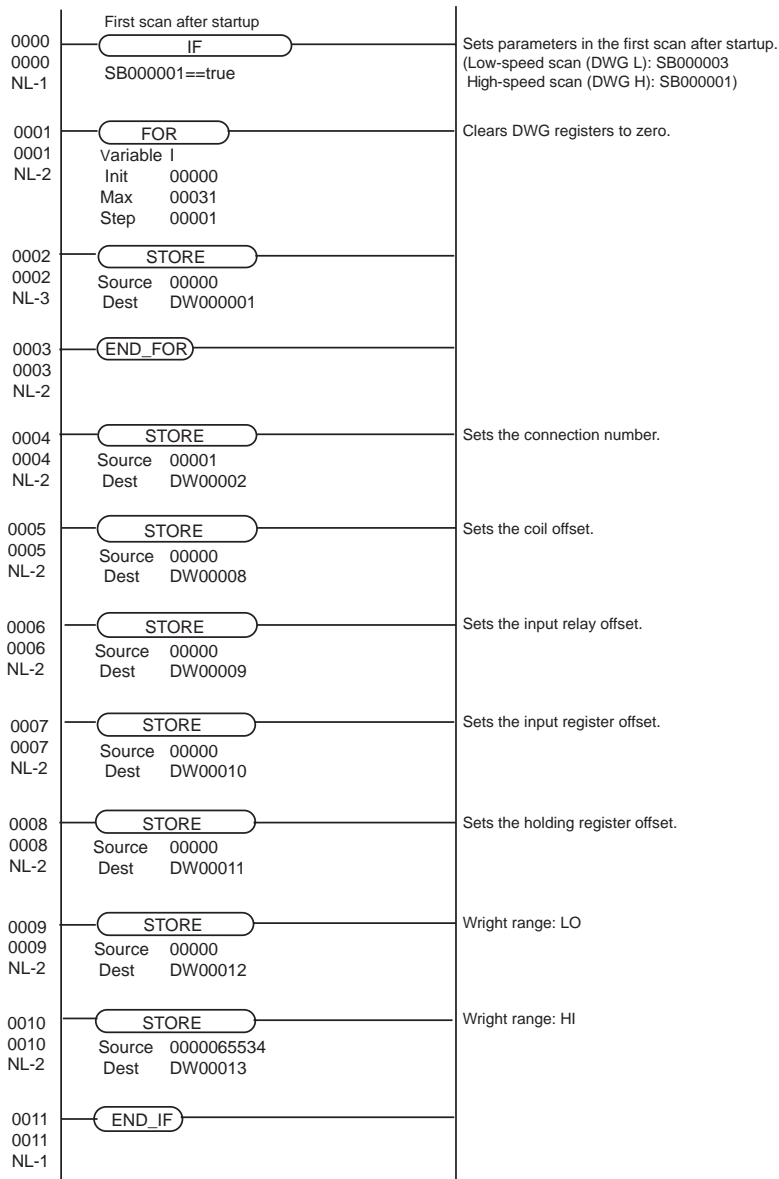

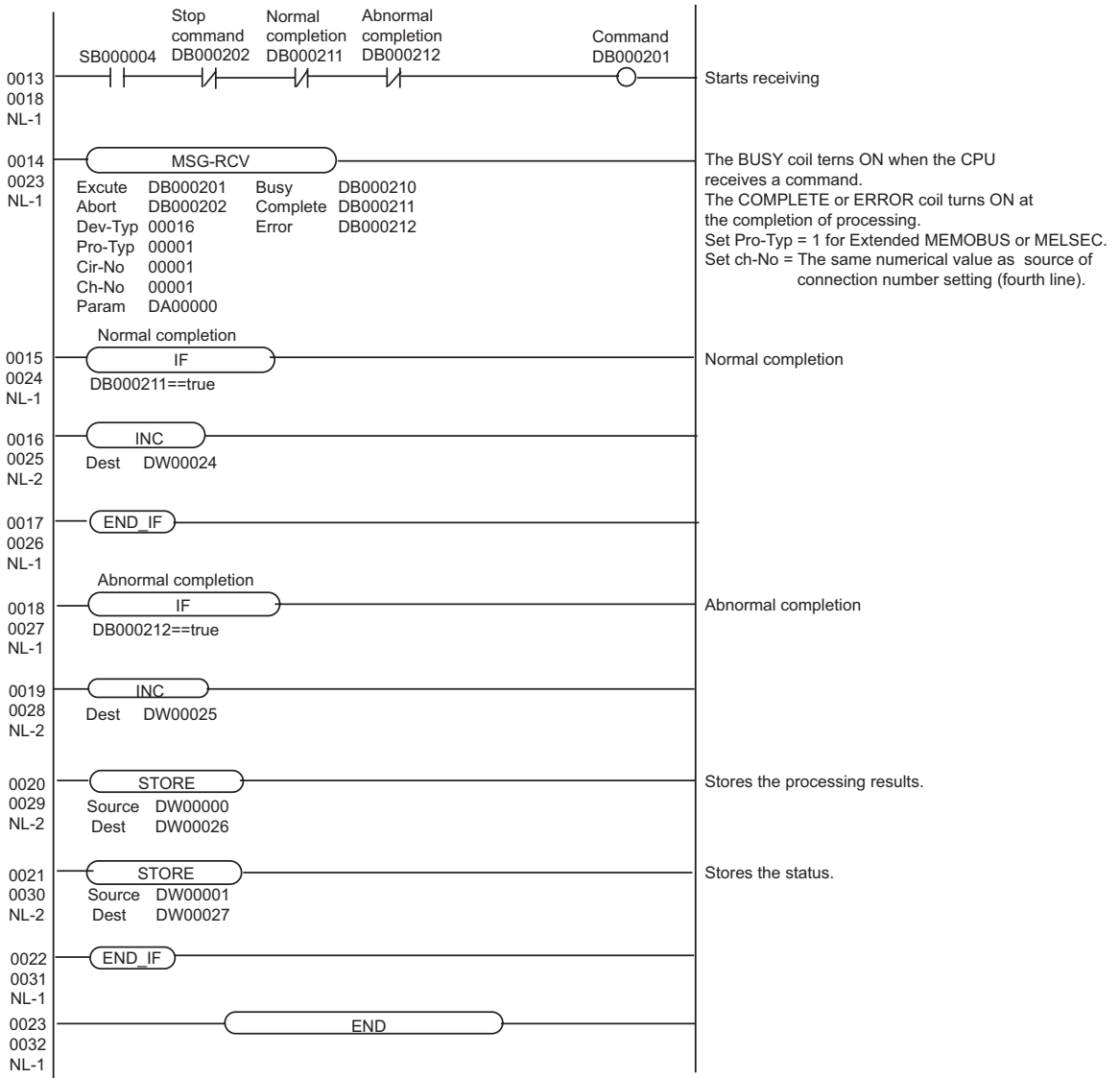

4 Setup Items

Set communication settings of the Display with GP-Pro EX or in offline mode of the Display.

The setting of each parameter must be identical to that of External Device.

 "3 Example of Communication Setting" (page 6)

NOTE • Set the Display's IP address in offline mode.

Cf. Maintenance/Troubleshooting Guide "Ethernet Settings"

4.1 Setup Items in GP-Pro EX

■ Communication Settings

To display the setting screen, select [Device/PLC Settings] from [System setting window] in workspace.

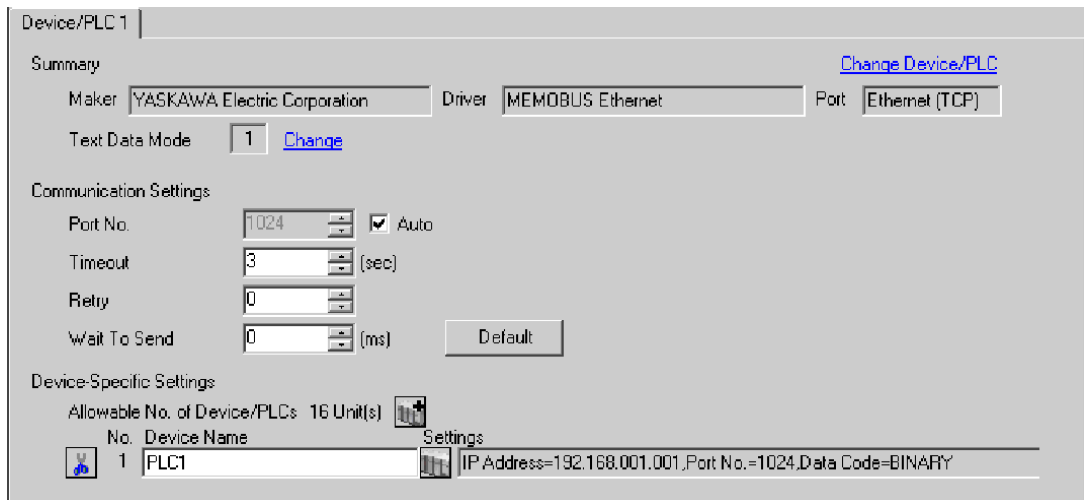

Device/PLC 1

Summary [Change Device/PLC](#)

Maker: YASKAWA Electric Corporation Driver: MEMOBUS Ethernet Port: Ethernet (TCP)

Text Data Mode: 1 [Change](#)

Communication Settings

Port No.: 1024 Auto

Timeout: 3 (sec)

Retry: 0

Wait To Send: 0 (ms) [Default](#)

Device-Specific Settings

Allowable No. of Device/PLCs: 16 Unit(s)

No.	Device Name	Settings
1	PLC1	IP Address=192.168.001.001, Port No.=1024, Data Code=BINARY

Setup Items	Setup Description
Port No.	Enter a port number of the External Device, using 1024 to 65535. Check into [Auto], and a port number is set automatically. NOTE Set the [Auto], when select the [Ethernet (TCP)] in [Connection Method] only.
Timeout	Use an integer from 1 to 127 to enter the time (s) for which Display waits for the response from External Device.
Retry	In case of no response from the External Device, use an integer from 0 to 255 to enter how many times the Display retransmits the command.
Wait To Send	Use an integer from 0 to 255 to enter standby time (ms) for the Display from receiving packets to transmitting next commands.

◆ Device Setting

To display the setting screen, click  ([Setting]) of External Device you want to set from [Device-Specific Settings] of [Device/PLC Settings].

When you connect multiple External Device, click  from [Device-Specific Settings] of [Device/PLC Settings] to add another External Device.

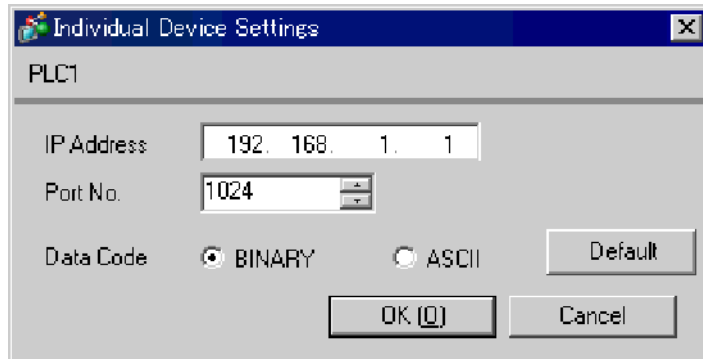

Setup Items	Setup Description
IP Address	Set IP address of the External Device. NOTE • Check with a network administrator about IP address. Do not set the duplicate IP address.
Port No.	Enter a port number of the External Device, using 256 to 65534.
Data Code	Select the data format in communication with the PLC.

4.2 Setup Items in Offline Mode

NOTE

- Refer to the Maintenance/Troubleshooting guide for information on how to enter offline mode or about the operation.

Cf. Maintenance/Troubleshooting Guide "Offline Mode"

◆ Communication Settings

To display the setting screen, touch [Device/PLC Settings] from [Peripheral Settings] in offline mode. Touch the External Device you want to set from the displayed list.

Comm.	Device			
MEMOBUS Ethernet		[TCP]	Page 1/1	
Port No.	<input type="radio"/> Fixed <input checked="" type="radio"/> Auto	<input type="text" value="1024"/> ▼ ▲		
Timeout(s)		<input type="text" value="3"/> ▼ ▲		
Retry		<input type="text" value="0"/> ▼ ▲		
Wait To Send(ms)		<input type="text" value="0"/> ▼ ▲		
	Exit	Back	2006/01/31 15:42:04	

Setup Items	Setup Description
Port No.	Enter a port number of the GP-Pro EX. The port number that input is assigned without being concerned with select of "Fixed" "Auto" by UDP connection. Select either of "Fixed" "Auto" by TCP connection. Enter a port number of the GP-Pro EX with "1024-65535", when select "Fixed". Assign automatically without affecting the input value, when select "Auto".
Timeout	Use an integer from 1 to 127 to enter the time (s) for which Display waits for the response from External Device.
Retry	In case of no response from the External Device, use an integer from 0 to 255 to enter how many times the Display retransmits the command.
Wait To Send	Use an integer from 0 to 255 to enter standby time (ms) for the Display from receiving packets to transmitting next commands.

■ Device Setting

To display the setting screen, touch [Device/PLC Settings] from [Peripheral Settings]. Touch the External Device you want to set from the displayed list, and touch [Device].



Comm.	Device			
MEMOBUS Ethernet		[TCP]		Page 1/1
Device/PLC Name	PLC1 ▼			
IP Address	192 168 1 1			
Port No.	1024 ▼ ▲			
Data Code	<input checked="" type="radio"/> BINARY <input type="radio"/> ASCII			
Exit		Back		2006/01/31 15:42:07

Setup Items	Setup Description
Device/PLC Name	Select the External Device for device setting. Device name is a title of External Device set with GP-Pro EX.(Initial value [PLC1])
IP Address	Set IP address of the External Device. <div style="border: 1px solid black; padding: 2px; display: inline-block; margin-bottom: 5px;">NOTE</div> <ul style="list-style-type: none"> • Check with a network administrator about IP address. Do not set the duplicate IP address.
Port No.	Enter a port number of the External Device, using 256 to 65534.
Data Code	Select the data format in communication with the External Device.

5 Supported Device

Range of supported device address is shown in the table below. Please note that the actually supported range of the devices varies depending on the External Device to be used. Please check the actual range in the manual of your External Device.

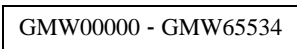
 This address can be specified as system data area.

Device	Bit address	Word address	32 bits	Remarks
Enhancing Coil	EGMB000000 - EGMB65534F	EGMB00000 - EGMB65534	L / H	*1
Enhancing Input Relay	EGIB000000 - EGIB7FFFFF	EGIB00000 - EGIB7FFF		*2
Coil	GMB000000 - GMB4095F	GMB00000 - GMB4095		
Input Relay	GIB000000 - GIB0FFFFF	GIB00000 - GIB0FFF		*2
Input Register	-----	GIW00000 - GIW7FFF		 *2
Holding Register	-----	 GMW00000 - GMW65534		

*1 When you write the bit address, the Display reads the word address corresponding to that of the External Device first. Then, it changes the target bit address among the word data once read and returns the word data to the External Device. Note that the correct data may not be written if you change the word address value in the ladder program while the Display reads the data of the External Device and returns it to the External Device.

*2 Write disable

The address of GP becomes the address which added an offset to the real address of the External Device.

Address relations of GP and External Device are as follows.

Device	Display on GP-Pro EX	Display on External Device
Enhancing Coil (Bit device)	EGMB000000 - EGMB65534F	MW000000+Offset - MW65534F+Offset
Enhancing Coil (Word device)	EGMB000000 - EGMB65534	MW00000+Offset - MW65534+Offset
Coil (Bit device)	GMB000000 - GMB4095F	MB00000+Offset - MB4095F+Offset
Coil (Word device)	GMB00000 - GMB4095	MB0000+Offset - MB4095+Offset
Enhancing Input Relay (Bit device)	EGIB000000 - EGIB7FFFFF	IW00000+Offset - IW7FFFFF+Offset
Enhancing Input Relay (Word device)	EGIB00000 - EGIB7FFF	IW0000+Offset - IW7FFF+Offset
Input Relay (Bit device)	GIB000000 - GIB0FFFFF	IB00000+Offset - IB0FFFFF+Offset
Input Relay (Word device)	GIB00000 - GIB0FFF	IB0000+Offset - IB0FFF+Offset
Input Register	GIW00000 - GIW7FFF	IW0000+Offset - IW7FFF+Offset
Holding Register	GMW000000 - GMW65534	MW00000+Offset - MW65534+Offset

e.g) When you specify "GMW0000" in GP-Pro EX, the address of "MW00000" to which offset value is added, is specified as the actual address in the External Device. Offset value is described as "Head REG" in the ladder software.

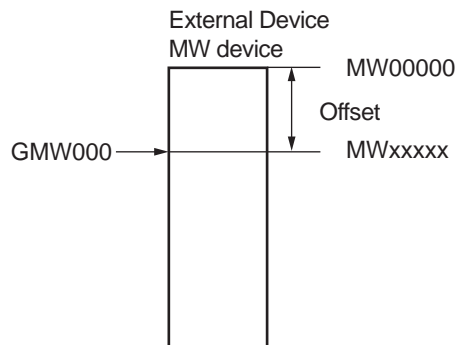
**NOTE**

- Please refer to the GP-Pro EX Reference Manual for system data area.
Cf. GP-Pro EX Reference Manual "LS Area (Direct Access Method Area)"
- Please refer to the precautions on manual notation for icons in the table.

☞ "Manual Symbols and Terminology"

6 Device Code and Address Code

Use device code and address code when you select "Device Type & Address" for the address type in data displays.

Device	Device Name	Device Code (HEX)	Address Code
Coil	GMB	0080	Word Address
Input Relay	GIB	0081	Word Address
Enhancing Coil	EGMB	0090	Word Address
Enhancing Input Relay	EGIB	0091	Word Address
Input Register	GIW	0001	Word Address
Holding Register	GMW	0000	Word Address

7 Error Messages

Error messages are displayed on the screen of Display as follows: "No. : Device Name: Error Message (Error Occurrence Area)". Each description is shown below.

Item	Description
No.	Error No.
Device Name	Name of External Device where error occurs. Device name is a title of External Device set with GP-Pro EX. (Initial value [PLC1])
Error Message	Displays messages related to the error which occurs.
Error Occurrence Area	<p>Displays IP address or device address of External Device where error occurs, or error codes received from External Device.</p> <p>NOTE</p> <ul style="list-style-type: none"> • IP address is displayed such as "IP address (Decimal): MAC address (Hex)". • Device address is displayed such as "Address: Device address". • Received error codes are displayed such as "Decimal [Hex]".

Display Examples of Error Messages

"RHAA035: PLC1: Error has been responded for device write command (Error Code: 2 [02H])"

NOTE

- Refer to your External Device manual for details on received error codes.
- Refer to "Display-related errors" in "Maintenance/Troubleshooting Guide" for details on the error messages common to the driver.

■ Error Code Peculiar to External Device

The error code peculiar to External Device is as follows.

Error	Code cause
01	Function code error
02	Address error for coil, input relay and register
03	Number error for coil, input relay and register

