



# INVERTER SIO Driver

1	System Configuration.....	3
2	External Device Selection .....	7
3	Communication Settings .....	8
4	Setup Items .....	28
5	Cable Diagrams .....	32
6	Supported Device Addresses.....	93
7	Device Code and Address Code.....	100
8	Error Messages.....	104

## Introduction

This manual describes how to connect the Display and the External Device (target inverter).

In this manual, the connection procedure is described in the sections identified below:

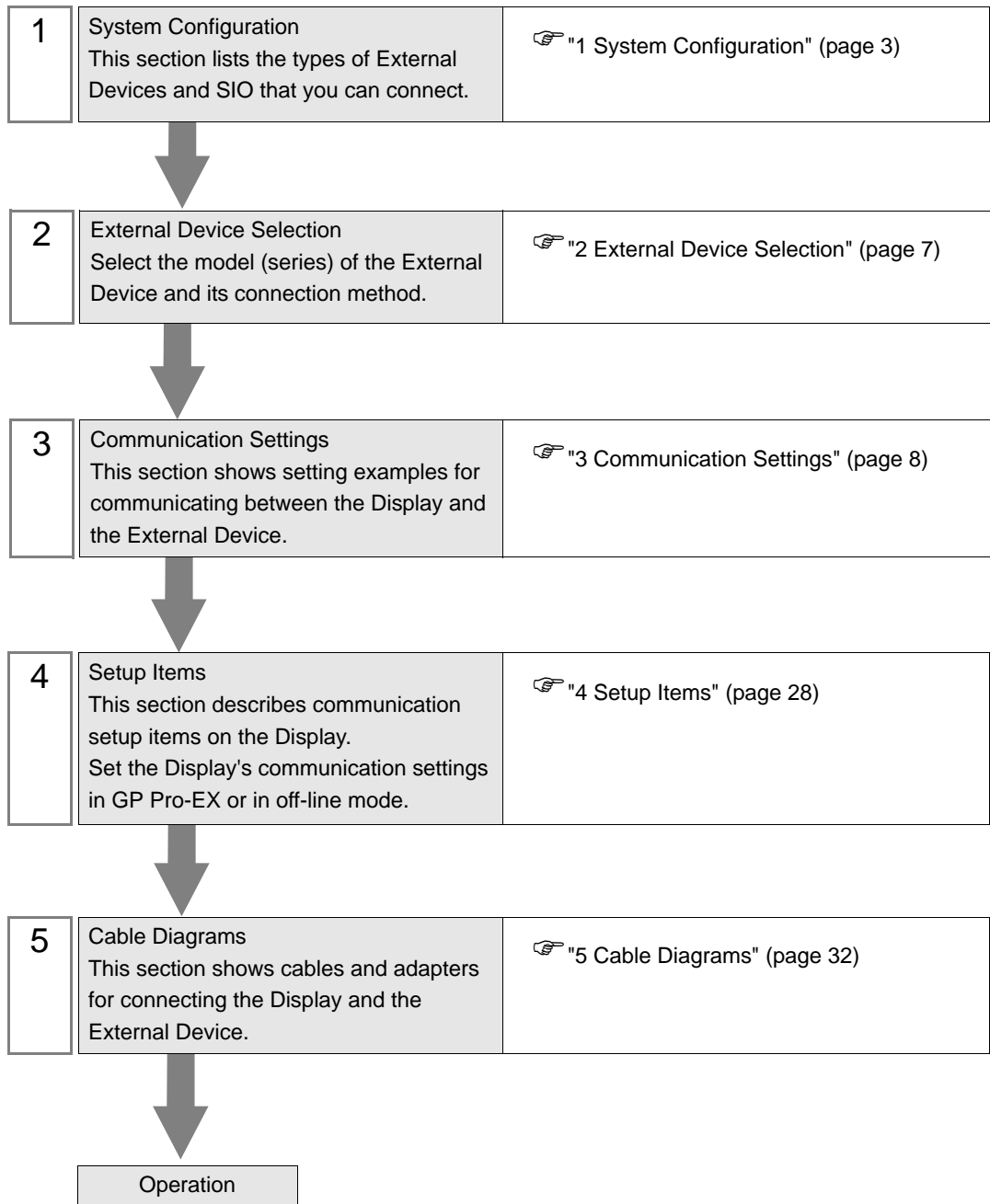

# 1 System Configuration

The following section shows system configurations for connecting Fuji Electric Co.,Ltd. External Devices and the Display.

Series	Inverter*1	Link I/F	SIO Type	Setting Example	Cable Diagram
FRENIC5000G11S	FRN□□□G11S-□	Terminal block on the inverter	RS-422/485 (2 wire)	Setting Example 1 (page 8)	Cable Diagram 1 (page 32)
FRENIC5000P11S	FRN□□□P11S-□	Terminal block on the inverter	RS-422/485 (2 wire)	Setting Example 1 (page 8)	Cable Diagram 1 (page 32)
FVR-E11S	FVR□□□E11S-□	RJ-45 connector on the inverter	RS-422/485 (2 wire)	Setting Example 2 (page 10)	Cable Diagram 2 (page 44)
FVR-C11S	FVR□□□C11S-□	Terminal block on OPC-C11S-RS■*2	RS-422/485 (2 wire)	Setting Example 3 (page 12)	Cable Diagram 4 (page 69)
FRENIC-MEGA	FRN□□□G1□-□	RJ-45 connector on the inverter	RS-422/485 (2 wire)	Setting Example 4 (page 14)	Cable Diagram 2 (page 44)
		Terminal block on the inverter	RS-422/485 (2 wire)	Setting Example 5 (page 16)	Cable Diagram 3 (page 57)
FRENIC-Mini	FRN□□□C1□-□	RJ-45 connector on OPC-C1-RS*3	RS-422/485 (2 wire)	Setting Example 6 (page 18)	Cable Diagram 2 (page 44)
FRENIC-Eco	FRN□□□F1□-□	RJ-45 connector on the inverter	RS-422/485 (2 wire)	Setting Example 7 (page 20)	Cable Diagram 2 (page 44)
		Terminal block on OPC-F1-RS*3	RS-422/485 (2 wire)	Setting Example 8 (page 22)	Cable Diagram 3 (page 57)
FRENIC-Multi	FRN□□□E1□-□	RJ-45 connector on the inverter	RS-422/485 (2 wire)	Setting Example 9 (page 24)	Cable Diagram 2 (page 44)
		RJ-45 connector on OPC-E1-RS*3	RS-422/485 (2 wire)	Setting Example 10 (page 26)	Cable Diagram 5 (page 81)

\*1 □ included in the inverter model names varies depending on the capacity, power supply and language.

\*2 The model code ■ for the option card shows the card type (either A, B or C) categorized according to capacity.

\*3 Communication card for the inverter

**IMPORTANT**

- If a communication error is generated while operating via RS-422/485, there is a possibility that the stop command will not be recognized via RS-422/485. This is dangerous, so be sure to perform an emergency stop using the External Device outer signal terminal's force stop function.
- If the alarm reset is done while the run command is on via RS-422/485, the External Device will reboot abruptly. This is dangerous, so be sure to reset the alarm after confirming that the run command is turned off.

■ Connection Configuration

- 1:1 Connection



- 1:n Connection

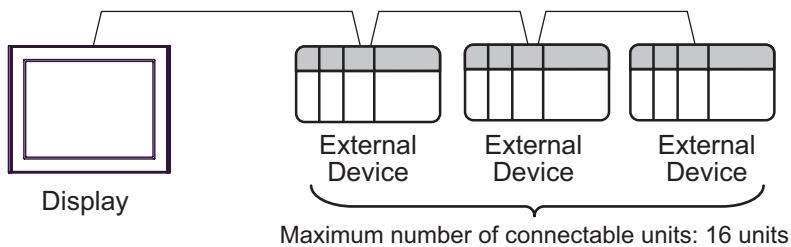

## ■ IPC COM Port

When connecting IPC with an External Device, the COM port used depends on the series and SIO type. Please refer to the IPC manual for details.

Usable port

Series	Usable Port		
	RS-232C	RS-422/485(4 wire)	RS-422/485(2 wire)
PS-2000B	COM1 <sup>*1</sup> , COM2, COM3 <sup>*1</sup> , COM4	-	-
PS-3450A, PS-3451A, PS3000-BA, PS3001-BD	COM1, COM2 <sup>*1*2</sup>	COM2 <sup>*1*2</sup>	COM2 <sup>*1*2</sup>
PS-3650A (T41 model), PS-3651A (T41 model)	COM1 <sup>*1</sup>	-	-
PS-3650A (T42 model), PS-3651A (T42 model)	COM1 <sup>*1*2</sup> , COM2	COM1 <sup>*1*2</sup>	COM1 <sup>*1*2</sup>
PS-3700A (Pentium®4-M) PS-3710A	COM1 <sup>*1</sup> , COM2 <sup>*1</sup> , COM3 <sup>*2</sup> , COM4	COM3 <sup>*2</sup>	COM3 <sup>*2</sup>
PS-3711A	COM1 <sup>*1</sup> , COM2 <sup>*2</sup>	COM2 <sup>*2</sup>	COM2 <sup>*2</sup>
PS4000 <sup>*3</sup>	COM1, COM2	-	-
PL3000	COM1 <sup>*1*2</sup> , COM2 <sup>*1</sup> , COM3, COM4	COM1 <sup>*1*2</sup>	COM1 <sup>*1*2</sup>

\*1 The RI/5V can be switched. Use the IPC's switch to change if necessary.

\*2 Set up the SIO type with the DIP Switch. Please set up as follows according to SIO type to be used.

\*3 When making communication between an External Device and COM port on the Expansion slot, only RS-232C is supported. However, ER (DTR/CTS) control cannot be executed because of the specification of COM port.

For connection with External Device, use user-created cables and disable Pin Nos. 1, 4, 6 and 9.

Please refer to the IPC manual for details of pin layout.

DIP Switch setting: RS-232C

DIP Switch	Setting	Description
1	OFF <sup>*1</sup>	Reserved (always OFF)
2	OFF	SIO type: RS-232C
3	OFF	
4	OFF	Output mode of SD (TXD) data: Always output
5	OFF	Terminal resistance (220Ω) insertion to SD (TXD): None
6	OFF	Terminal resistance (220Ω) insertion to RD (RXD): None
7	OFF	Short-circuit of SDA (TXA) and RDA (RXA): Not available
8	OFF	Short-circuit of SDB (TXB) and RDB (RXB): Not available
9	OFF	RS (RTS) Auto control mode: Disabled
10	OFF	

\*1 When using PS-3450A, PS-3451A, PS3000-BA and PS3001-BD, turn ON the set value.

## DIP Switch setting: RS-422/485 (4 wire)

DIP Switch	Setting	Description
1	OFF	Reserved (always OFF)
2	ON	SIO type: RS-422/485
3	ON	
4	OFF	Output mode of SD (TXD) data: Always output
5	OFF	Terminal resistance (220Ω) insertion to SD (TXD): None
6	OFF	Terminal resistance (220Ω) insertion to RD (RXD): None
7	OFF	Short-circuit of SDA (TXA) and RDA (RXA): Not available
8	OFF	Short-circuit of SDB (TXB) and RDB (RXB): Not available
9	OFF	RS (RTS) Auto control mode: Disabled
10	OFF	

## DIP Switch setting: RS-422/485 (2 wire)

DIP Switch	Setting	Description
1	OFF	Reserved (always OFF)
2	ON	SIO type: RS-422/485
3	ON	
4	OFF	Output mode of SD (TXD) data: Always output
5	OFF	Terminal resistance (220Ω) insertion to SD (TXD): None
6	OFF	Terminal resistance (220Ω) insertion to RD (RXD): None
7	ON	Short-circuit of SDA (TXA) and RDA (RXA): Available
8	ON	Short-circuit of SDB (TXB) and RDB (RXB): Available
9	ON	RS (RTS) Auto control mode: Enabled
10	ON	

## 2 External Device Selection

Select the External Device to be connected to the Display.

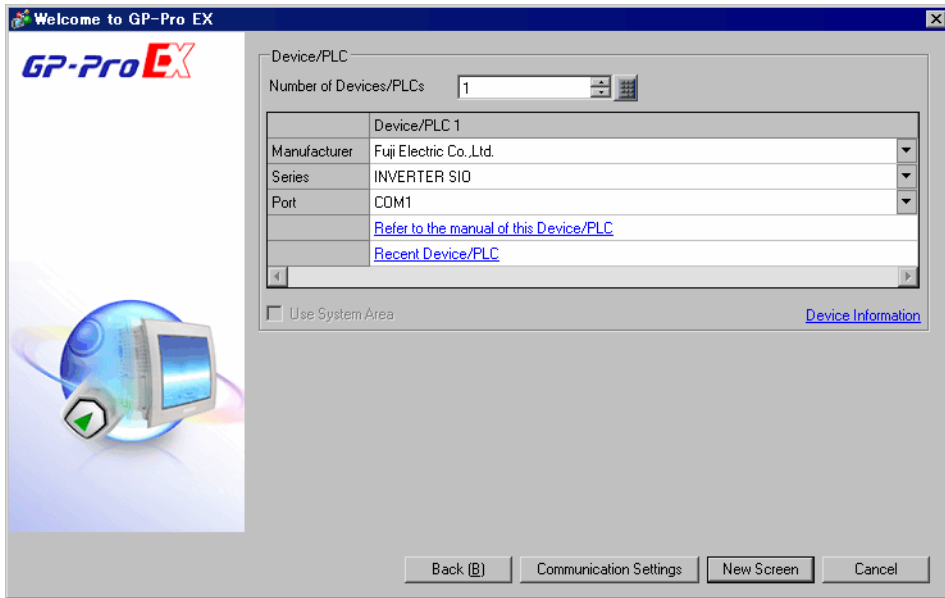

Setup Items	Setup Description
Number of Devices/PLCs	Use an integer from 1 to 4 to enter the number of Devices/PLCs to connect to the display.
Manufacturer	Select the manufacturer of the External Device to connect. Select "Fuji Electric Co.,Ltd.".
Series	Select the External Device model (series) and the connection method. Select "INVERTER SIO". In System configuration, make sure the External Device you are connecting is supported by "INVERTER SIO". ☞ "1 System Configuration" (page 3)
Port	Select the Display port to be connected to the External Device.
Use System Area	Not available in this driver.

## 3 Communication Settings

This section provides examples of communication settings recommended by Pro-face for the Display and the External Device.

### 3.1 Setting Example 1

#### ■ GP-Pro EX Settings

#### ◆ Communication Settings

To display the setup screen, from the [Project] menu, point to [System Settings] and select [Device/PLC].

Device/PLC 1

Summary [Change Device/PLC](#)

Manufacturer  Series  Port

Text Data Mode  [Change](#)

Communication Settings

SIO Type  RS232C  RS422/485(2wire)  RS422/485(4wire)

Speed

Data Length  7  8

Parity  NONE  EVEN  ODD

Stop Bit  1  2

Flow Control  NONE  ER(DTR/CTS)  XON/XOFF

Timeout  (sec)

Retry

Wait To Send  (ms)

RI / VCC  RI  VCC

In the case of RS232C, you can select the 9th pin to RI (Input) or VCC (5V Power Supply). If you use the Digital's RS232C Isolation Unit, please select it to VCC.

Device-Specific Settings

Allowable Number of Devices/PLCs  [Add Device](#)

No.	Device Name	Settings
<input type="button" value="1"/>	<input type="text" value="PLC1"/>	<input type="text" value="Series=FRENIC5000G11S/P11S,Station Address=1"/>

#### IMPORTANT

- Set Wait To Send to 1(ms) or more.



◆ Device Setting

To display the [Individual Device Settings] dialog box, from [Device-Specific Settings] in the [Device/PLC] window, select the external device and click [Settings] .

To connect multiple External Devices, from [Device-Specific Settings] in the [Device/PLC] window, click [Add Device] to add another External Device.



■ External Device Settings

To configure communication settings, use the PRG, FUNC/DATA, Up, Down, or SHIFT key on the touch panel located on the front of the External Device. Refer to your External Device manual for details.

- 1 Turn ON the power of the External Device.
- 2 Press the PRG key to move to the program menu.
- 3 Select [1. DATA SET], and press the FUNC/DATA key.
- 4 Press the Up, Down, or SHIFT key to select the function code you want to set.
- 5 Press the FUNC/DATA key.
- 6 Press the Up, Down, or SHIFT key to display the setting value.

Function Code	Setting	Setup Description
H31	1	Station address
H34	1	Speed
H35	0	Data length selection
H36	0	Parity bit selection
H37	0	Stop bit selection

- 7 Press the FUNC/DATA key.
- 8 Press the PRG key to move to the operation mode.
- 9 Reboot the External Device.

This completes the External Device settings.

### 3.2 Setting Example 2

#### ■ GP-Pro EX Settings

##### ◆ Communication Settings

To display the setup screen, from the [Project] menu, point to [System Settings] and select [Device/PLC].

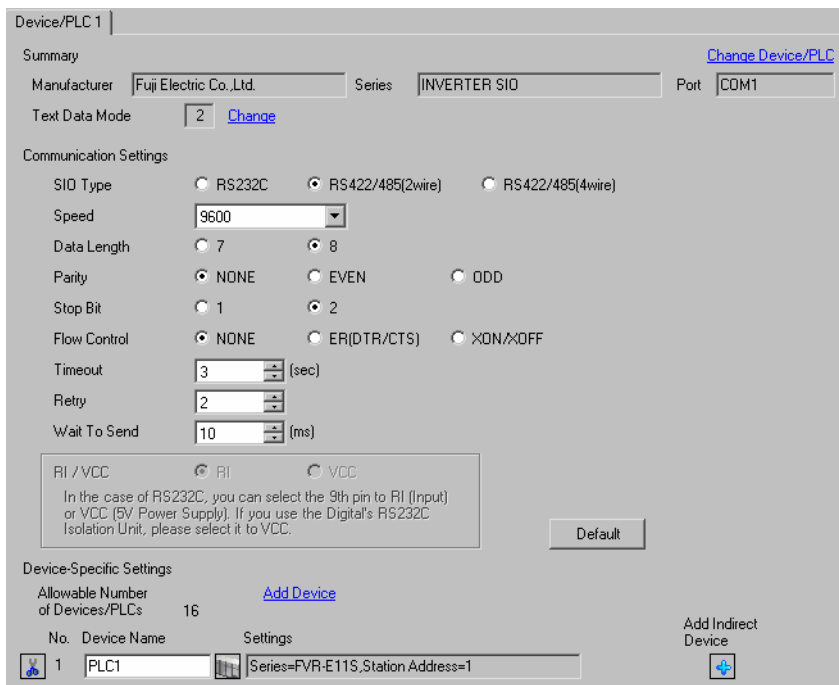

**IMPORTANT**

- Set Wait To Send to 10(ms) or more.

##### ◆ Device Setting

To display the [Individual Device Settings] dialog box, from [Device-Specific Settings] in the [Device/PLC] window, select the external device and click [Settings] .

To connect multiple External Devices, from [Device-Specific Settings] in the [Device/PLC] window, click [Add Device] to add another External Device.



## ■ External Device Settings

To configure communication settings, use the FUNC/DATA, Up, Down, or PRG/RESET key on the touch panel located on the front of the External Device. Refer to your External Device manual for details.

- 1 Turn ON the power of the External Device.
- 2 Press the PRG/RESET key to move to the program mode.
- 3 Press the Up or Down key to display the function code you want to set.
- 4 Press the FUNC/DATA key.
- 5 Press the Up or Down key to display the setting value.

Function Code	Setting	Setup Description
H31	1	Station address
H34	1	Speed
H35	0	Data length selection
H36	0	Parity bit selection
H37	1	Stop bit selection

- 6 Press the FUNC/DATA key.
- 7 Press the PRG/RESET key to move to the normal mode.
- 8 Reboot the External Device.

This completes the External Device settings.

### 3.3 Setting Example 3

#### ■ GP-Pro EX Settings

##### ◆ Communication Settings

To display the setup screen, from the [Project] menu, point to [System Settings] and select [Device/PLC].

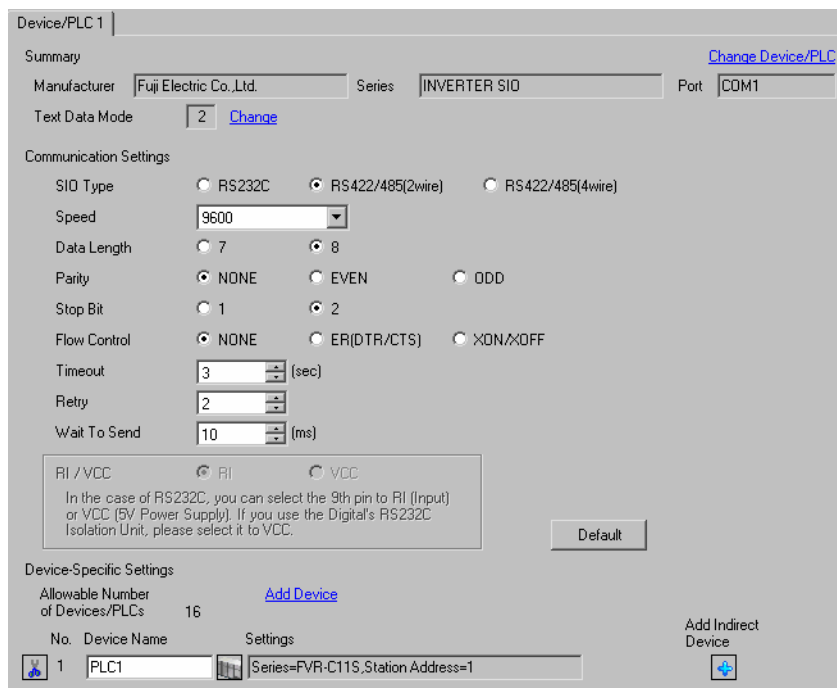

**IMPORTANT**

- Set Wait To Send to 10(ms) or more.

##### ◆ Device Setting

To display the [Individual Device Settings] dialog box, from [Device-Specific Settings] in the [Device/PLC] window, select the external device and click [Settings] .

To connect multiple External Devices, from [Device-Specific Settings] in the [Device/PLC] window, click [Add Device] to add another External Device.



## ■ External Device Settings

To configure communication settings, use the FUNC/DATA, Up, Down, or PRG/RESET key on the touch panel located on the front of the External Device. Refer to your External Device manual for details.

- 1 Turn ON the power of the External Device.
- 2 Press the PRG/RESET key to move to the program mode.
- 3 Press the Up or Down key to display the function code [o00].
- 4 Press the FUNC/DATA key.
- 5 Press the Up or Down key to display the setting value.

Function Code	Setting	Setup Description
o00	1	Option select (RS-485 Communications)

- 6 Press the FUNC/DATA key.
- 7 Press the Up or Down key to display the function code you want to set.
- 8 Press the Up or Down key to display the setting value.

Function Code	Setting	Setup Description
o01	1	Station address
o04	1	Speed
o05	0	Data length selection
o06	0	Parity bit selection
o07	0	Stop bit selection

- 9 Press the FUNC/DATA key.
- 10 Press the PRG/RESET key to move to the normal mode.
- 11 Reboot the External Device.

This completes the External Device settings.

### 3.4 Setting Example 4

#### ■ GP-Pro EX Settings

##### ◆ Communication Settings

To display the setup screen, from the [Project] menu, point to [System Settings] and select [Device/PLC].

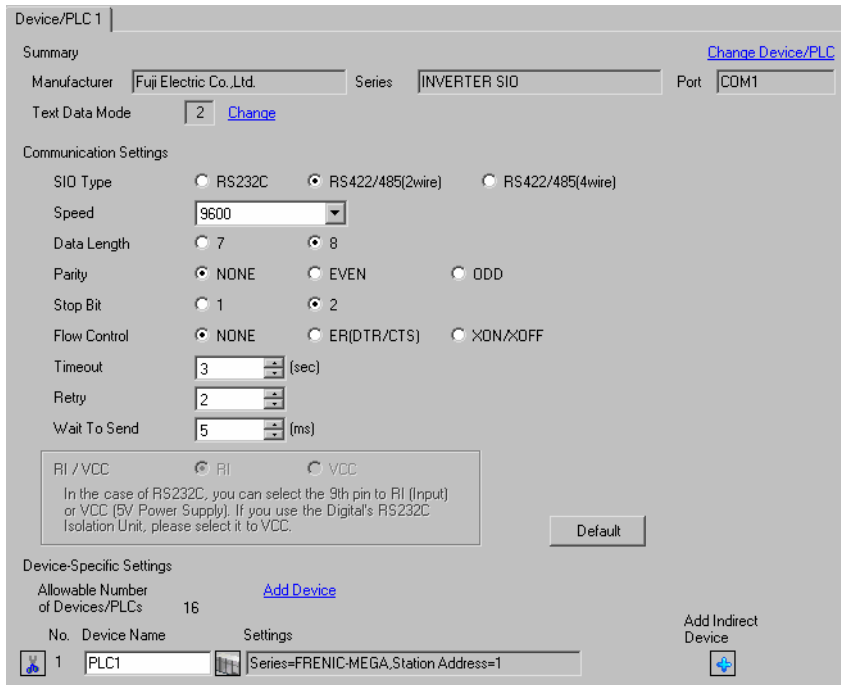

**IMPORTANT**

- Set Wait To Send to 5(ms) or more.

##### ◆ Device Setting

To display the [Individual Device Settings] dialog box, from [Device-Specific Settings] in the [Device/PLC] window, select the external device and click [Settings] .

To connect multiple External Devices, from [Device-Specific Settings] in the [Device/PLC] window, click [Add Device] to add another External Device.

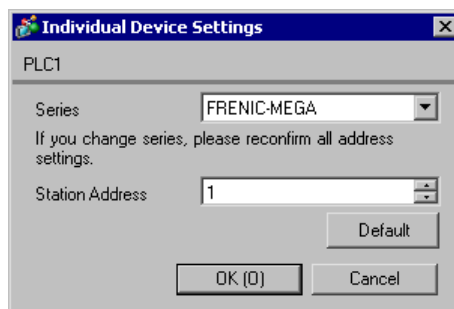

## ■ External Device Settings

To configure communication settings, use the FUNC/DATA, Up, Down, or PRG/RESET key on the touch panel located on the front of the External Device. Refer to your External Device manual for details.

- 1 Turn ON the power of the External Device.
- 2 Press the PRG/RESET key to move to the program mode.
- 3 Press the Up or Down key to display the function code group [1.Y\_ \_ ].
- 4 Press the FUNC/DATA key.
- 5 Press the Up or Down key to display the function code you want to set.
- 6 Press the FUNC/DATA key.
- 7 Press the Up or Down key to display the setting value.

Function Code	Setting	Setup Description
Y01	1	Station address
Y04	2	Speed
Y05	0	Data length selection
Y06	0	Parity bit selection
Y07	0	Stop bit selection
Y10	2	Protocol selection

- 8 Press the FUNC/DATA key.
- 9 Press the PRG/RESET key to move to the operation mode.
- 10 Reboot the External Device.

This completes the External Device settings.

### 3.5 Setting Example 5

#### ■ GP-Pro EX Settings

#### ◆ Communication Settings

To display the setup screen, from the [Project] menu, point to [System Settings] and select [Device/PLC].

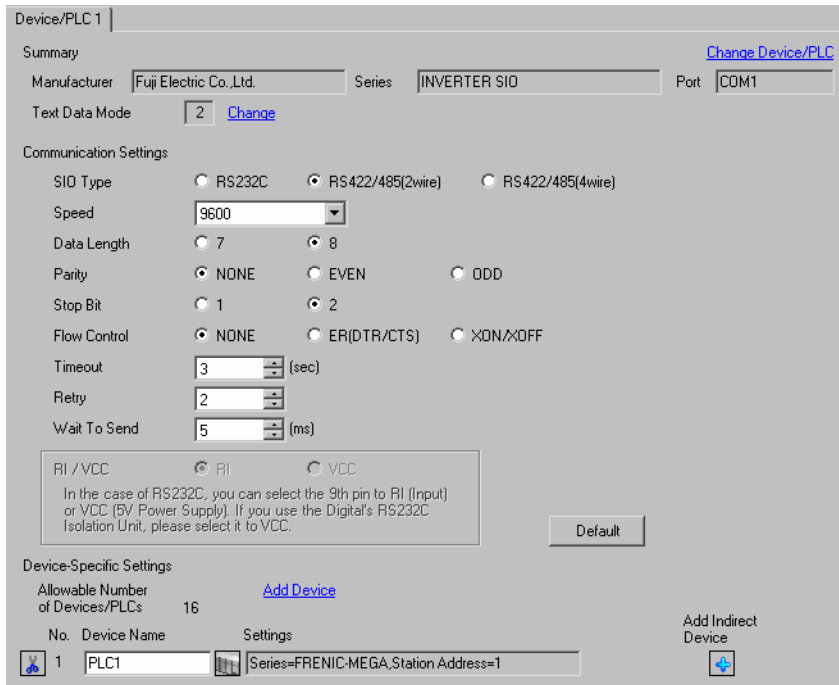

**IMPORTANT** • Set Wait To Send to 5(ms) or more.

#### ◆ Device Setting

To display the [Individual Device Settings] dialog box, from [Device-Specific Settings] in the [Device/PLC] window, select the external device and click [Settings] .

To connect multiple External Devices, from [Device-Specific Settings] in the [Device/PLC] window, click [Add Device] to add another External Device.

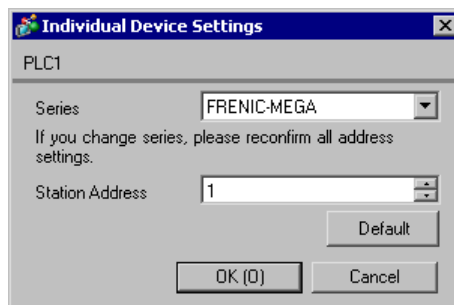



## ■ External Device Settings

To configure communication settings, use the FUNC/DATA, Up, Down, or PRG/RESET key on the touch panel located on the front of the External Device. Refer to your External Device manual for details.

- 1 Turn ON the power of the External Device.
- 2 Press the PRG/RESET key to move to the program mode.
- 3 Press the Up or Down key to display the function code group [1.Y\_ \_ ].
- 4 Press the FUNC/DATA key.
- 5 Press the Up or Down key to display the function code you want to set.
- 6 Press the FUNC/DATA key.
- 7 Press the Up or Down key to display the setting value.

Function Code	Setting	Setup Description
Y11	1	Station address
Y14	2	Speed
Y15	0	Data length selection
Y16	0	Parity bit selection
Y17	0	Stop bit selection
Y20	2	Protocol selection

- 8 Press the FUNC/DATA key.
- 9 Press the PRG/RESET key to move to the operation mode.
- 10 Reboot the External Device.

This completes the External Device settings.

### 3.6 Setting Example 6

#### ■ GP-Pro EX Settings

##### ◆ Communication Settings

To display the setup screen, from the [Project] menu, point to [System Settings] and select [Device/PLC].

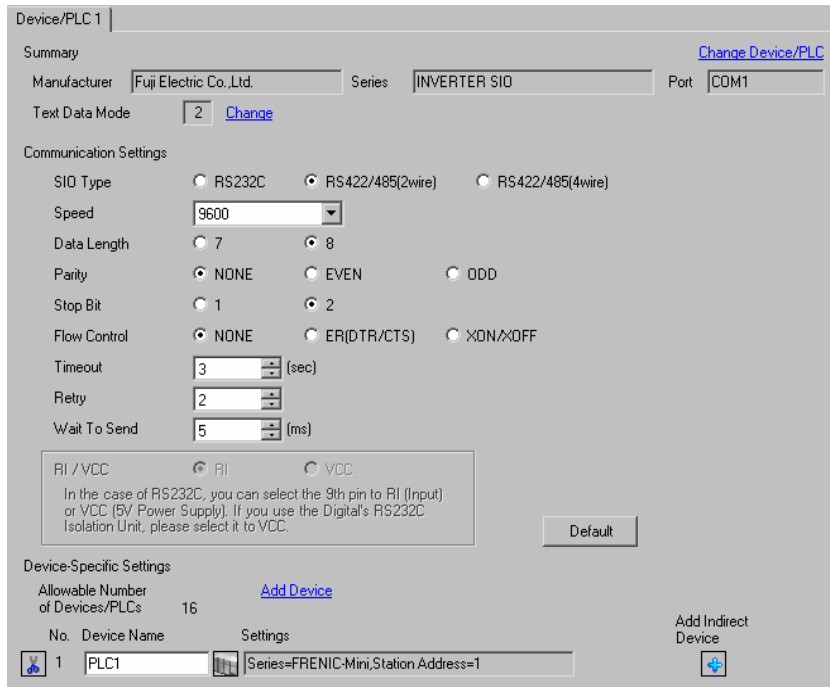

**IMPORTANT** • Set Wait To Send to 5(ms) or more.

##### ◆ Device Setting

To display the [Individual Device Settings] dialog box, from [Device-Specific Settings] in the [Device/PLC] window, select the external device and click [Settings] .

To connect multiple External Devices, from [Device-Specific Settings] in the [Device/PLC] window, click [Add Device] to add another External Device.

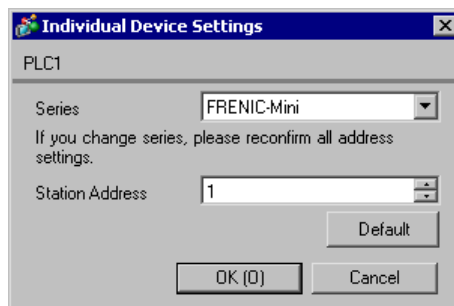

## ■ External Device Settings

To configure communication settings, use the FUNC/DATA, Up, Down, or PRG/RESET key on the touch panel located on the front of the External Device. Refer to your External Device manual for details.

- 1 Turn ON the power of the External Device.
- 2 Press the PRG/RESET key to move to the program mode.
- 3 Press the Up or Down key to display the function code group [1.Y\_ \_ ].
- 4 Press the FUNC/DATA key.
- 5 Press the Up or Down key to display the function code you want to set.
- 6 Press the FUNC/DATA key.
- 7 Press the Up or Down key to display the setting value.

Function Code	Setting	Setup Description
Y01	1	Station address
Y04	2	Speed
Y05	0	Data length selection
Y06	0	Parity bit selection
Y07	0	Stop bit selection
Y10	2	Protocol selection

- 8 Press the FUNC/DATA key.
- 9 Press the PRG/RESET key to move to the operation mode.
- 10 Reboot the External Device.

This completes the External Device settings.

### 3.7 Setting Example 7

#### ■ GP-Pro EX Settings

##### ◆ Communication Settings

To display the setup screen, from the [Project] menu, point to [System Settings] and select [Device/PLC].

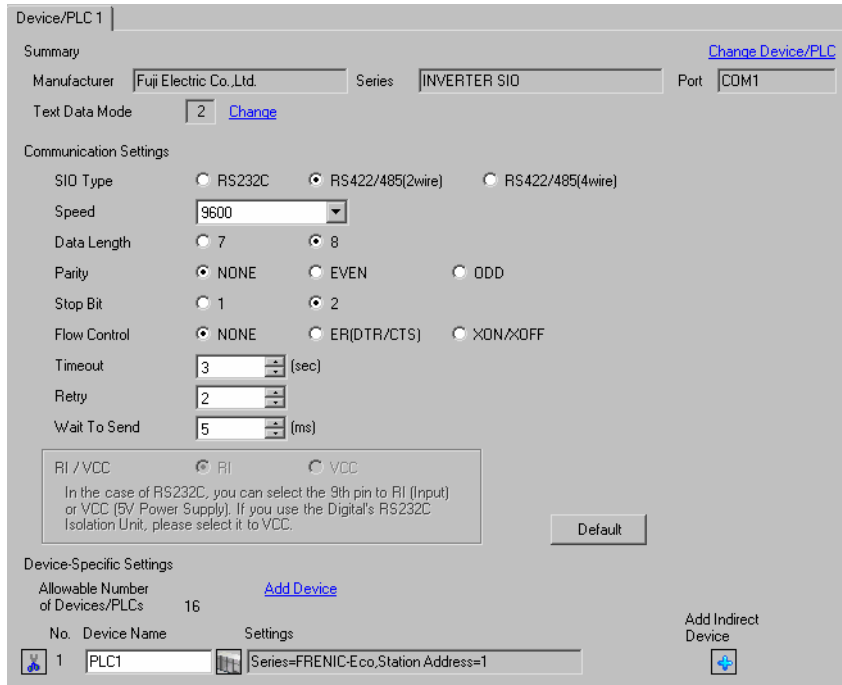

**IMPORTANT** • Set Wait To Send to 5(ms) or more.

##### ◆ Device Setting

To display the [Individual Device Settings] dialog box, from [Device-Specific Settings] in the [Device/PLC] window, select the external device and click [Settings] .

To connect multiple External Devices, from [Device-Specific Settings] in the [Device/PLC] window, click [Add Device] to add another External Device.



## ■ External Device Settings

To configure communication settings, use the FUNC/DATA, Up, Down, or PRG/RESET key on the touch panel located on the front of the External Device. Refer to your External Device manual for details.

- 1 Turn ON the power of the External Device.
- 2 Press the PRG/RESET key to move to the program mode.
- 3 Press the Up or Down key to display the function code group [1.Y\_ \_ ].
- 4 Press the FUNC/DATA key.
- 5 Press the Up or Down key to display the function code you want to set.
- 6 Press the FUNC/DATA key.
- 7 Press the Up or Down key to display the setting value.

Function Code	Setting	Setup Description
Y01	1	Station address
Y04	2	Speed
Y05	0	Data length selection
Y06	0	Parity bit selection
Y07	0	Stop bit selection
Y10	2	Protocol selection

- 8 Press the FUNC/DATA key.
- 9 Press the PRG/RESET key to move to the operation mode.
- 10 Reboot the External Device.

This completes the External Device settings.

### 3.8 Setting Example 8

#### ■ GP-Pro EX Settings

##### ◆ Communication Settings

To display the setup screen, from the [Project] menu, point to [System Settings] and select [Device/PLC].

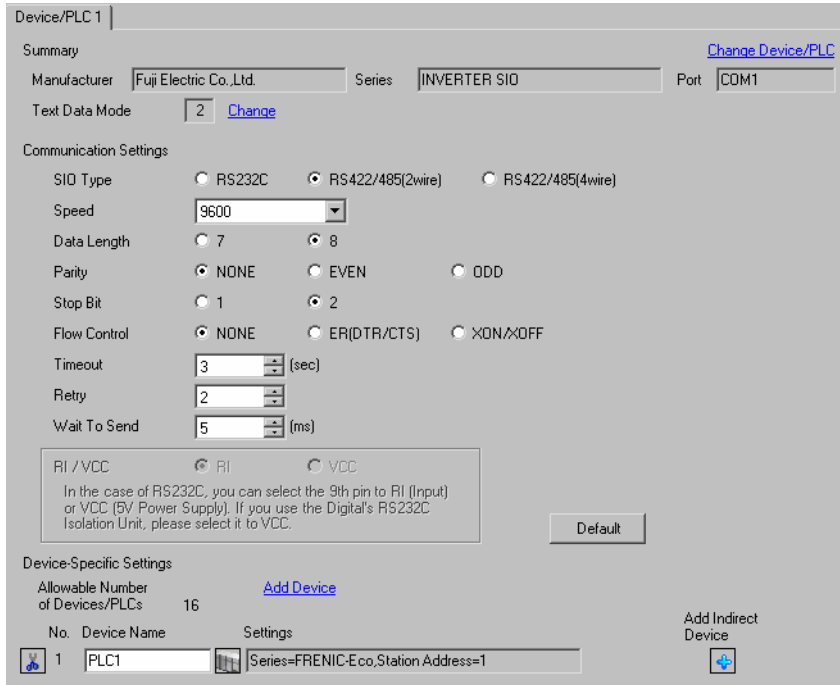

**IMPORTANT** • Set Wait To Send to 5(ms) or more.

##### ◆ Device Setting

To display the [Individual Device Settings] dialog box, from [Device-Specific Settings] in the [Device/PLC] window, select the external device and click [Settings] .

To connect multiple External Devices, from [Device-Specific Settings] in the [Device/PLC] window, click [Add Device] to add another External Device.



## ■ External Device Settings

To configure communication settings, use the FUNC/DATA, Up, Down, or PRG/RESET key on the touch panel located on the front of the External Device. Refer to your External Device manual for details.

- 1 Turn ON the power of the External Device.
- 2 Press the PRG/RESET key to move to the program mode.
- 3 Press the Up or Down key to display the function code group [1.Y\_ \_ ].
- 4 Press the FUNC/DATA key.
- 5 Press the Up or Down key to display the function code you want to set.
- 6 Press the FUNC/DATA key.
- 7 Press the Up or Down key to display the setting value.

Function Code	Setting	Setup Description
Y11	1	Station address
Y14	2	Speed
Y15	0	Data length selection
Y16	0	Parity bit selection
Y17	0	Stop bit selection
Y20	2	Protocol selection

- 8 Press the FUNC/DATA key.
- 9 Press the PRG/RESET key to move to the operation mode.
- 10 Reboot the External Device.

This completes the External Device settings.

### 3.9 Setting Example 9

#### ■ GP-Pro EX Settings

##### ◆ Communication Settings

To display the setup screen, from the [Project] menu, point to [System Settings] and select [Device/PLC].

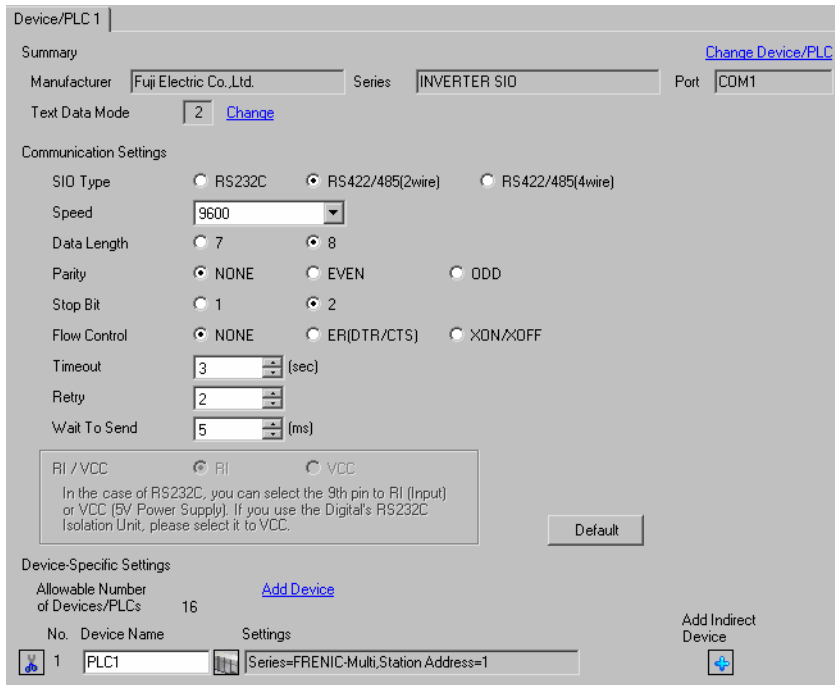

**IMPORTANT**

- Set Wait To Send to 5(ms) or more.

##### ◆ Device Setting

To display the [Individual Device Settings] dialog box, from [Device-Specific Settings] in the [Device/PLC] window, select the external device and click [Settings].

To connect multiple External Devices, from [Device-Specific Settings] in the [Device/PLC] window, click [Add Device] to add another External Device.

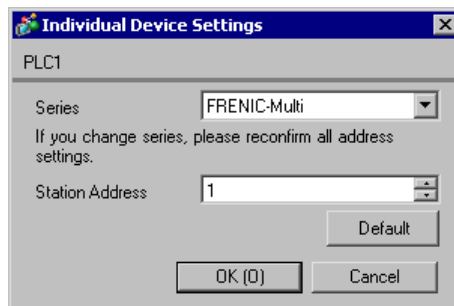



## ■ External Device Settings

To configure communication settings, use the FUNC/DATA, Up, Down, or PRG/RESET key on the touch panel located on the front of the External Device. Refer to your External Device manual for details.

- 1 Turn ON the power of the External Device.
- 2 Press the PRG/RESET key to move to the program mode.
- 3 Press the Up or Down key to display the function code group [1.Y\_ \_ ].
- 4 Press the FUNC/DATA key.
- 5 Press the Up or Down key to display the function code you want to set.
- 6 Press the FUNC/DATA key.
- 7 Press the Up or Down key to display the setting value.

Function Code	Setting	Setup Description
Y01	1	Station address
Y04	2	Speed
Y05	0	Data length selection
Y06	0	Parity bit selection
Y07	0	Stop bit selection
Y10	2	Protocol selection

- 8 Press the FUNC/DATA key.
- 9 Press the PRG/RESET key to move to the operation mode.
- 10 Reboot the External Device.

This completes the External Device settings.

### 3.10 Setting Example 10

#### ■ GP-Pro EX Settings

#### ◆ Communication Settings

To display the setup screen, from the [Project] menu, point to [System Settings] and select [Device/PLC].

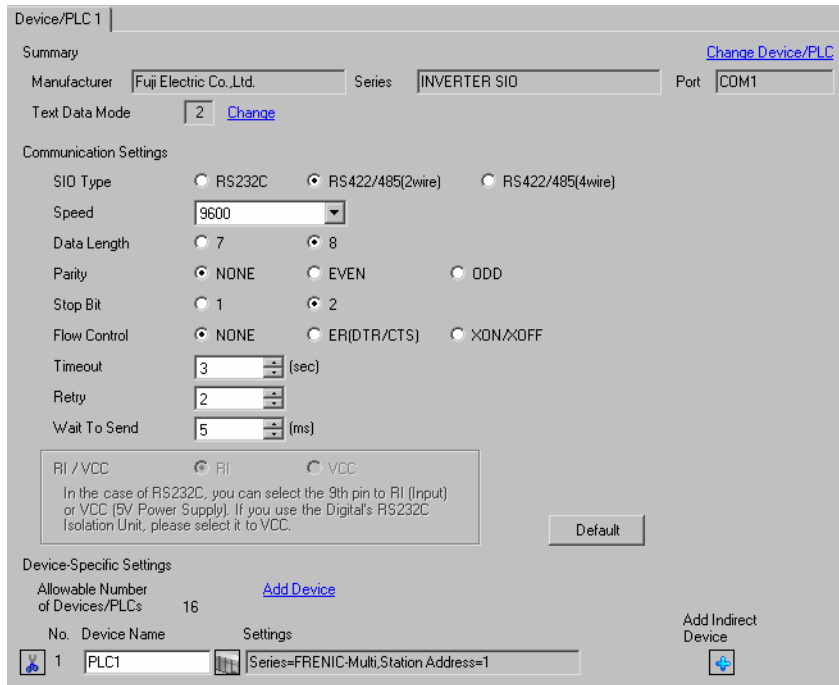

**IMPORTANT** • Set Wait To Send to 5(ms) or more.

#### ◆ Device Setting

To display the [Individual Device Settings] dialog box, from [Device-Specific Settings] in the [Device/PLC] window, select the external device and click [Settings] .

To connect multiple External Devices, from [Device-Specific Settings] in the [Device/PLC] window, click [Add Device] to add another External Device.

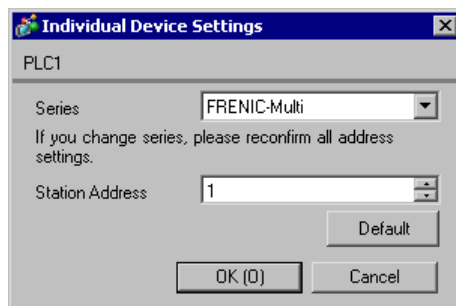

## ■ External Device Settings

To configure communication settings, use the FUNC/DATA, Up, Down, or PRG/RESET key on the touch panel located on the front of the External Device. Refer to your External Device manual for details.

- 1 Turn ON the power of the External Device.
- 2 Press the PRG/RESET key to move to the program mode.
- 3 Press the Up or Down key to display the function code group [1.Y\_ \_ ].
- 4 Press the FUNC/DATA key.
- 5 Press the Up or Down key to display the function code you want to set.
- 6 Press the FUNC/DATA key.
- 7 Press the Up or Down key to display the setting value.

Function Code	Setting	Setup Description
Y11	1	Station address
Y14	2	Speed
Y15	0	Data length selection
Y16	0	Parity bit selection
Y17	0	Stop bit selection
Y20	2	Protocol selection

- 8 Press the FUNC/DATA key.
- 9 Press the PRG/RESET key to move to the operation mode.
- 10 Reboot the External Device.

This completes the External Device settings.

## 4 Setup Items

Set up the Display's communication settings in GP Pro-EX or in the Display's off-line mode.

The setting of each parameter must match that of the External Device.

☞ "3 Communication Settings" (page 8)

### 4.1 Setup Items in GP-Pro EX

#### ■ Communication Settings

To display the setup screen, from the [Project] menu, point to [System Settings] and select [Device/PLC].

Device/PLC 1

Summary [Change Device/PLC](#)

Manufacturer  Series  Port

Text Data Mode  [Change](#)

Communication Settings

SIO Type  RS232C  RS422/485(2wire)  RS422/485(4wire)

Speed

Data Length  7  8

Parity  NONE  EVEN  ODD

Stop Bit  1  2

Flow Control  NONE  ER(DTR/CTS)  XON/XOFF

Timeout  (sec)

Retry

Wait To Send  (ms)

RI / VCC  RI  VCC

In the case of RS232C, you can select the 9th pin to RI (Input) or VCC (5V Power Supply). If you use the Digital's RS232C Isolation Unit, please select it to VCC.

Device-Specific Settings

Allowable Number of Devices/PLCs 16 [Add Device](#)

No. Device Name Settings

Setup Items	Setup Description
SIO Type	Select the SIO type to communicate with the External Device. <b>IMPORTANT</b> In the communication settings, set [SIO Type] correctly according to the serial interface specifications of the Display. If you select an SIO type that the serial interface does not support, proper operation cannot be guaranteed. Refer to your Display manual for details on the serial interface specifications.
Speed	Select the communication speed between the External Device and the Display.
Data Length	Select the data length.
Parity	Select how to check parity.
Stop Bit	Select the stop bit length.
Flow Control	Select a communication control method to prevent transmission and reception data overflow.

continued to next page

Setup Items	Setup Description
Timeout	Enter the time (seconds) for which the Display waits for the response from the External Device, from "1 to 127". <b>NOTE</b> <ul style="list-style-type: none"> <li>If the Timeout value is set to less than 10(s), it will be changed to 10(s) when initializing the External Device from the Display. After initialization, it will return to the original set value.</li> </ul>
Retry	In case of no response from the External Device, use an integer from 0 to 255 to enter how many times the Display retransmits the command.
Wait To Send	Enter the standby time (milliseconds) from when the Display receives packets until it transmits the next command, from "0 to 255".

**NOTE**

- Refer to the GP-Pro EX Reference Manual for Indirect Device.
- Cf. GP-Pro EX Reference Manual "Changing the Device/PLC at Runtime (Indirect Device)"

■ Device Settings

To display the [Individual Device Settings] dialog box, from [Device-Specific Settings] in the [Device/PLC] window, select the external device and click [Settings]  .

To connect multiple External Devices, from [Device-Specific Settings] in the [Device/PLC] window, click [Add Device] to add another External Device.

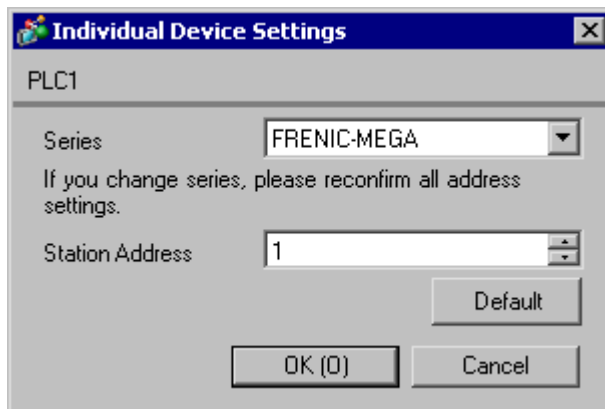

Setup Items	Setup Description
Series	Select the series of the External Device.
Station Address	Enter the station address of the External Device, using 1 to 31.

## 4.2 Setup Items in Off-line Mode

**NOTE**

- Refer to the Maintenance/Troubleshooting manual for information on how to enter off-line mode or about the operation.  
Cf. Maintenance/Troubleshooting Manual "Off-line Mode"
- The number of the setup items to be displayed for 1 page in the off-line mode depends on the Display in use. Please refer to the Reference manual for details.

### ■ Communication Settings

To display the setting screen, touch [Device/PLC Settings] from [Peripheral Equipment Settings] in off-line mode. Touch the External Device you want to set from the displayed list.

Comm.	Device	Option		
INVERTER SIO		[COM1]	Page 1/1	
SIO Type	RS422/485(2wire) ▼			
Speed	9600 ▼			
Data Length	<input type="radio"/> 7 <input checked="" type="radio"/> 8			
Parity	<input checked="" type="radio"/> NONE <input type="radio"/> EVEN <input type="radio"/> ODD			
Stop Bit	<input type="radio"/> 1 <input checked="" type="radio"/> 2			
Flow Control	NONE ▼			
Timeout(s)	3 ▼ ▲			
Retry	2 ▼ ▲			
Wait To Send(ms)	5 ▼ ▲			
Exit		Back		2009/04/05 03:05:22

Setup Items	Setup Description
SIO Type	Select the SIO type to communicate with the External Device. <b>IMPORTANT</b> In the communication settings, set [SIO Type] correctly according to the serial interface specifications of the Display. If you select an SIO type that the serial interface does not support, proper operation cannot be guaranteed. Refer to your Display manual for details on the serial interface specifications.
Speed	Select the communication speed between the External Device and the Display.
Data Length	Select the data length.
Parity	Select how to check parity.
Stop Bit	Select the stop bit length.
Flow Control	Select a communication control method to prevent transmission and reception data overflow.

continued to next page

Setup Items	Setup Description
Timeout	Enter the time (seconds) for which the Display waits for the response from the External Device, from "1 to 127". <b>NOTE</b> <ul style="list-style-type: none"> <li>If the Timeout value is set to less than 10(s), it will be changed to 10(s) when initializing the External Device from the Display. After initialization, it will return to the original set value.</li> </ul>
Retry	In case of no response from the External Device, use an integer from 0 to 255 to enter how many times the Display retransmits the command.
Wait To Send	Enter the standby time (milliseconds) from when the Display receives packets until it transmits the next command, from "0 to 255".

### ■ Device Setting

To display the setting screen, touch [Device/PLC Settings] from [Peripheral Equipment Settings]. Touch the External Device you want to set from the displayed list, and touch [Device Settings].

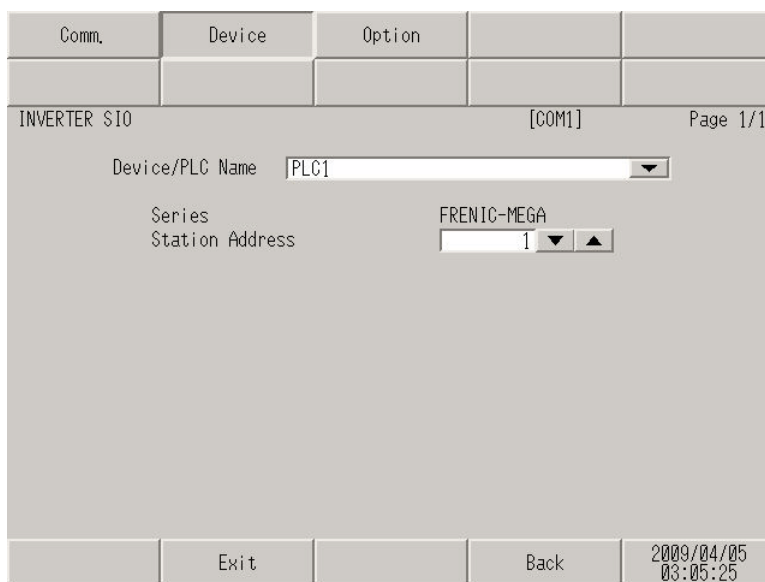

Setup Items	Setup Description
Device/PLC Name	Select the External Device to set as a device. Device/PLC name is the title of the External Device set with GP-Pro EX. (Initial value [PLC1])
Series	Displays the series of the External Device.
Station Address	Enter the station address of the External Device, using 1 to 31.

## 5 Cable Diagrams

The following cable diagrams may be different from cable diagrams recommended by Fuji Electric Co.,Ltd. Please be assured there is no operational problem in applying the cable diagrams shown in this manual.

- Please ground the FG pin of the External Device body. Use a grounding resistance of 100Ω 2mm<sup>2</sup> or thicker wire, or your country's applicable standard. Refer to your External Device manual for more details.
- The SG and FG are connected inside the Display. When connecting the External Device to the SG, design your system to avoid short-circuit loops.
- Connect an isolation unit if the communication is not stable due to noise or other factors.

Cable Diagram 1

Display (Connection Port)	Cable		Remarks
GP3000* <sup>1</sup> (COM1) AGP-3302B (COM2) GP-4*0ITM (COM1) ST* <sup>2</sup> (COM2) LT3000 (COM1)	1A	COM port conversion adapter by Pro-face CA3-ADPCOM-01 + Terminal block conversion adapter by Pro-face CA3-ADPTRM-01 + User-created cable	Cable length: 500m or less
	1B	User-created cable	
GP3000* <sup>3</sup> (COM2)	1C	Online adapter by Pro-face CA4-ADPONL-01 + Terminal block conversion adapter by Pro-face CA3-ADPTRM-01 + User-created cable	
	1D	Online adapter by Pro-face CA4-ADPONL-01 + User-created cable	
IPC* <sup>4</sup>	1E	COM port conversion adapter by Pro-face CA3-ADPCOM-01 + Terminal block conversion adapter by Pro-face CA3-ADPTRM-01 + User-created cable	
	1F	User-created cable	
GP-4106 (COM1)	1G	User-created cable	
GP-4107 (COM1) GP-4*03T* <sup>5</sup> (COM2) GP-4203T (COM1)	1H	User-created cable	

Continues to the next page.



Display (Connection Port)	Cable		Remarks
GP4000* <sup>6</sup> (COM2) GP-4201T (COM1)	1I	RS-422 Terminal Block Conversion Adapter by Pro-face PFXZCBADTM1* <sup>7</sup> + User-created cable	Cable length: 500m or less
	1B	User-created cable	
LT-4*01TM (COM1)	1J	RJ45 RS-485 Cable (5m) by Pro-face PFXZLMCBRJR81	

\*1 All GP3000 models except AGP-3302B

\*2 All ST models except AST-3211A and AST-3302B

\*3 All GP3000 models except the GP-3200 Series and AGP-3302B

\*4 Only the COM port which can communicate by RS-422/485 (2-wire) can be used.

☞ ■ IPC COM Port (page 5)

\*5 Except GP-4203T

\*6 All GP4000 models except GP-4100 Series, GP-4\*01TM, GP-4201T and GP-4\*03T

\*7 When using a Terminal Block Conversion Adapter (CA3-ADPTRM-01) instead of the RS-422 Terminal Block Conversion Adapter, refer to Cable Diagram 1A.

- The recommended connection cable is the Furukawa Electric's AWM2789 long-distance cable.

**IMPORTANT**

- Depending on the operating environment, malfunctions may occur due to External Device noise. In this case, connect the ferrite core or condenser to the cable.

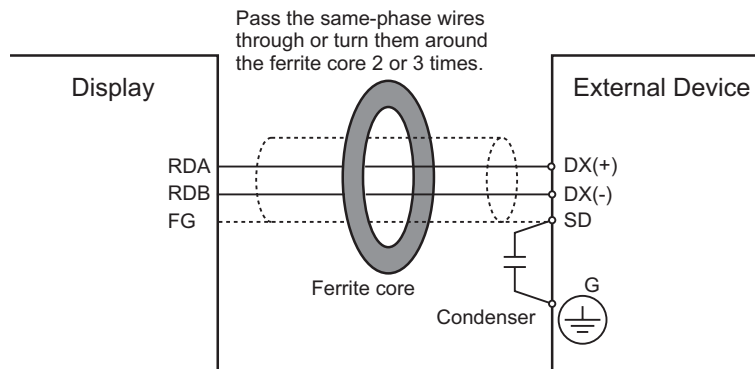

1A)

- 1:1 Connection

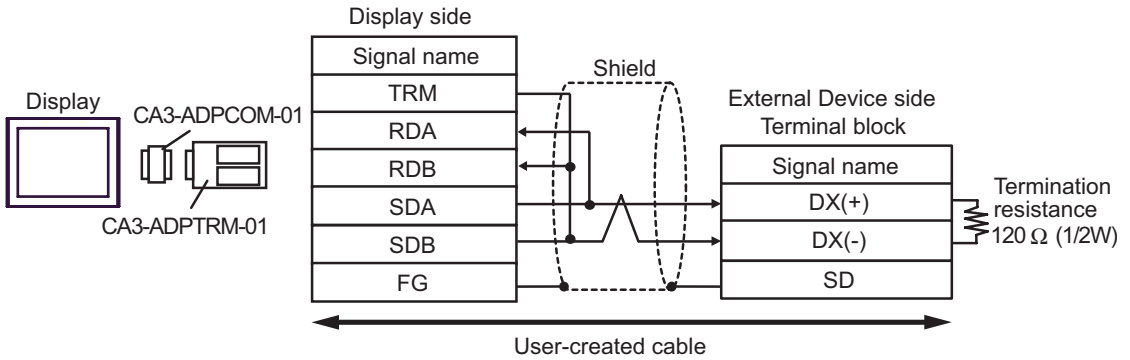

- 1:n Connection

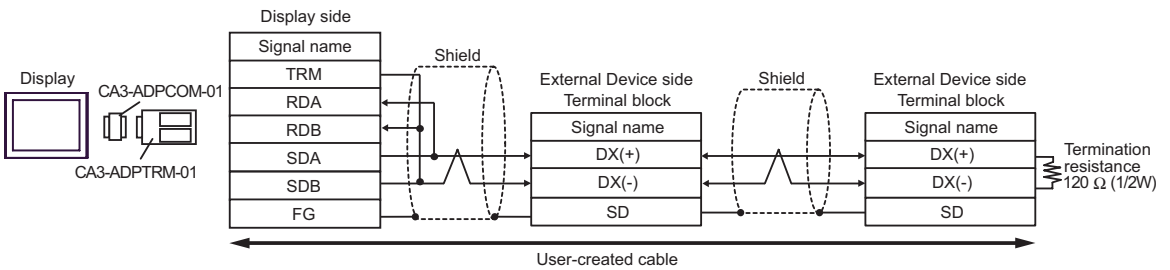

1B)

- 1:1 Connection

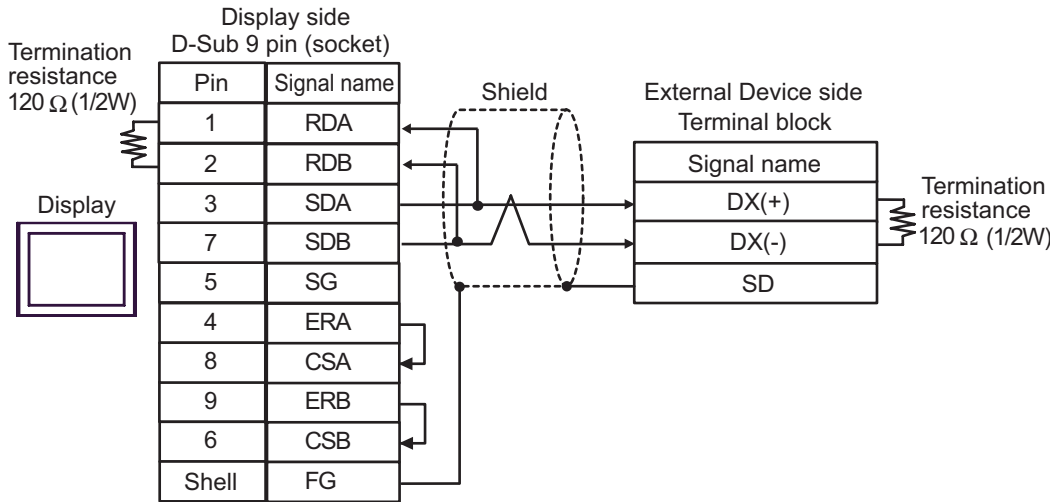

- 1:n Connection

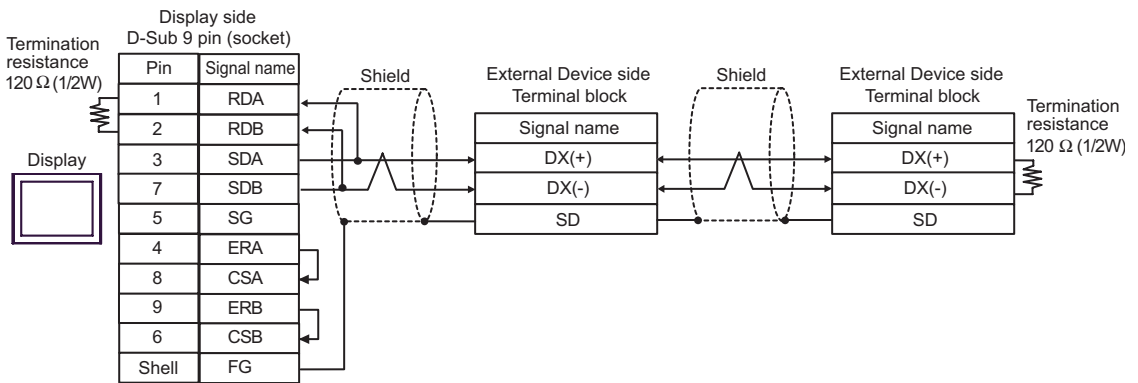

1C)

- 1:1 Connection

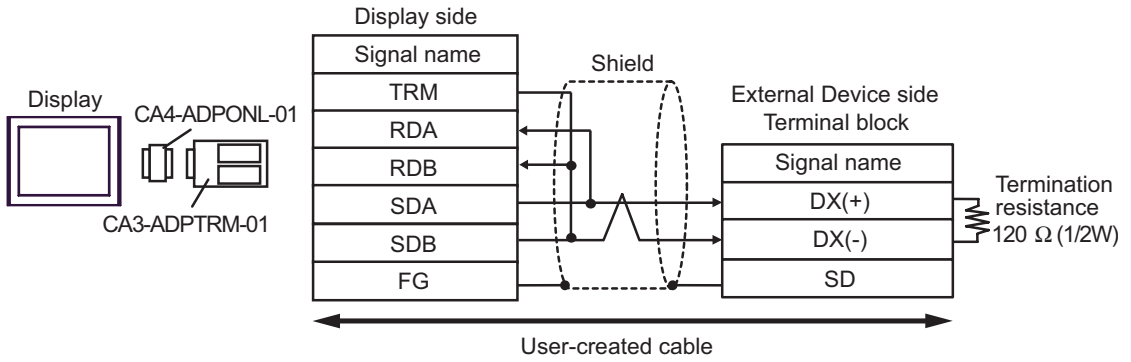

- 1:n Connection

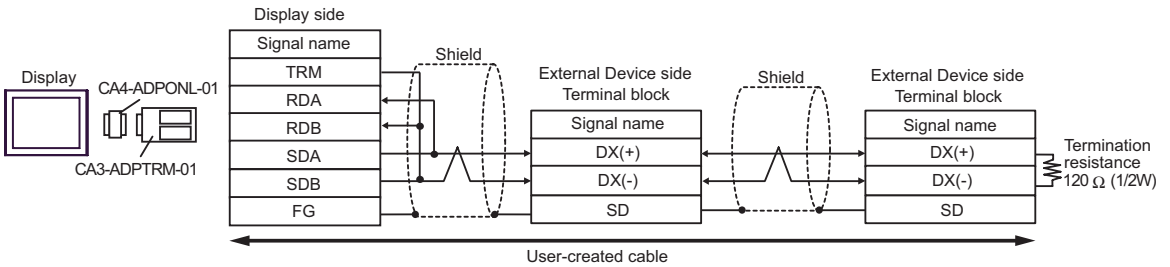

1D)

- 1:1 Connection

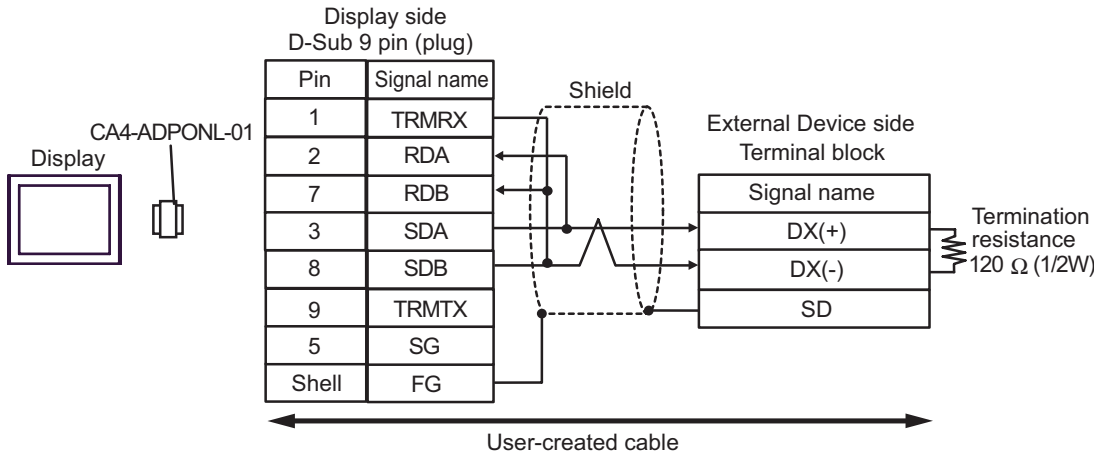

- 1:n Connection

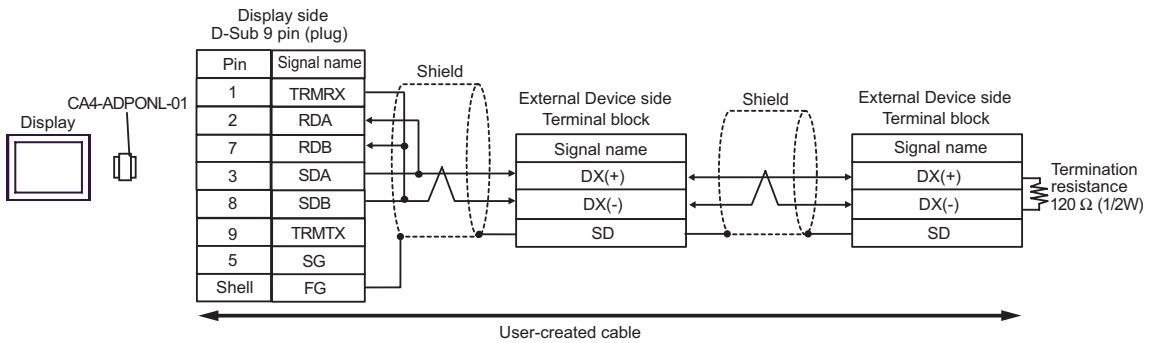

1E)

- 1:1 Connection

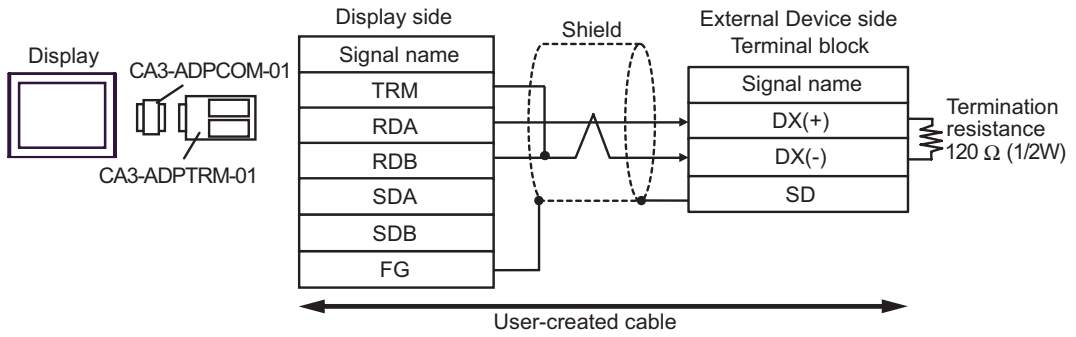

- 1:n Connection

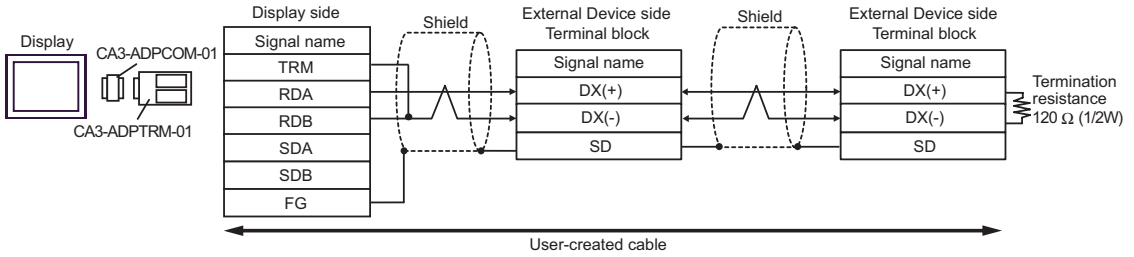

1F)

- 1:1 Connection

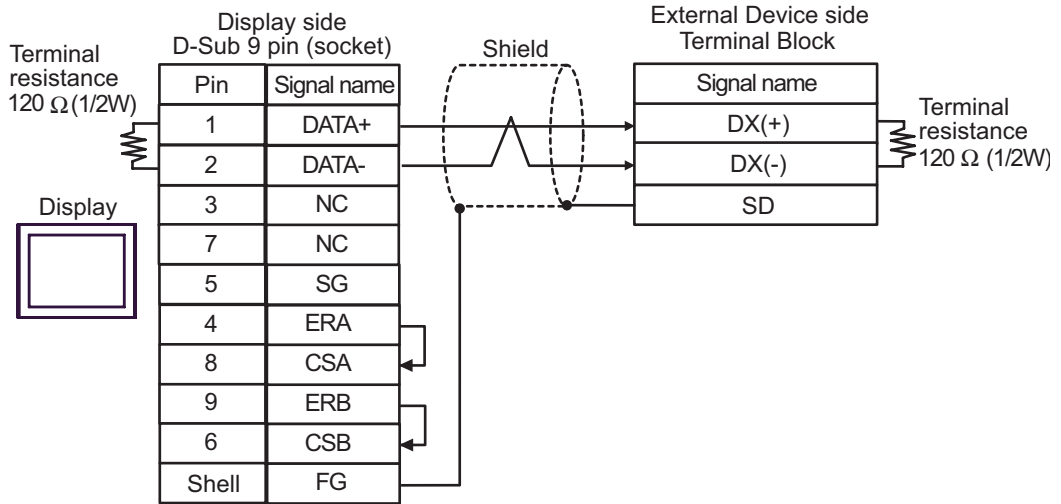

- 1:n Connection

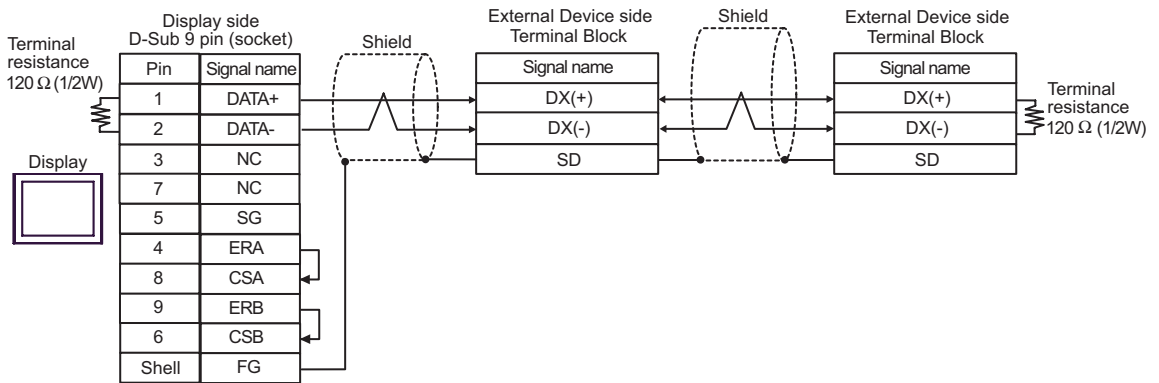

1G)

- 1:1 Connection

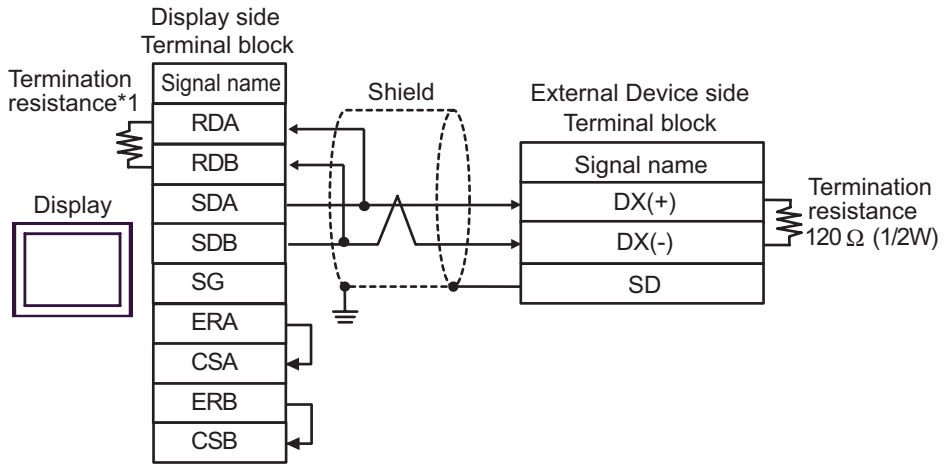

- 1:n Connection

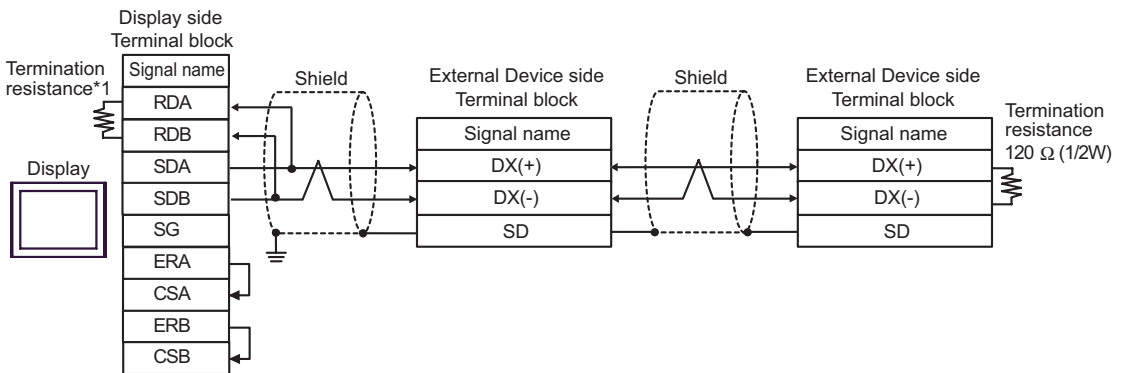

\*1 The resistance in the Display is used as the termination resistance. Set the value of the DIP Switch on the rear of the Display as shown in the table below.

DIP Switch No.	Set Value
1	OFF
2	OFF
3	ON
4	ON



1H)

- 1:1 Connection

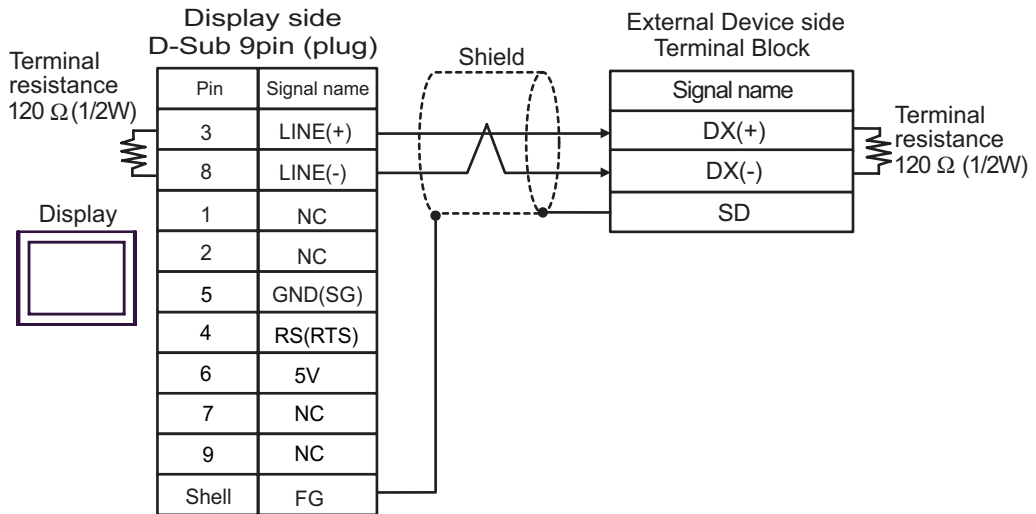

- 1:n Connection

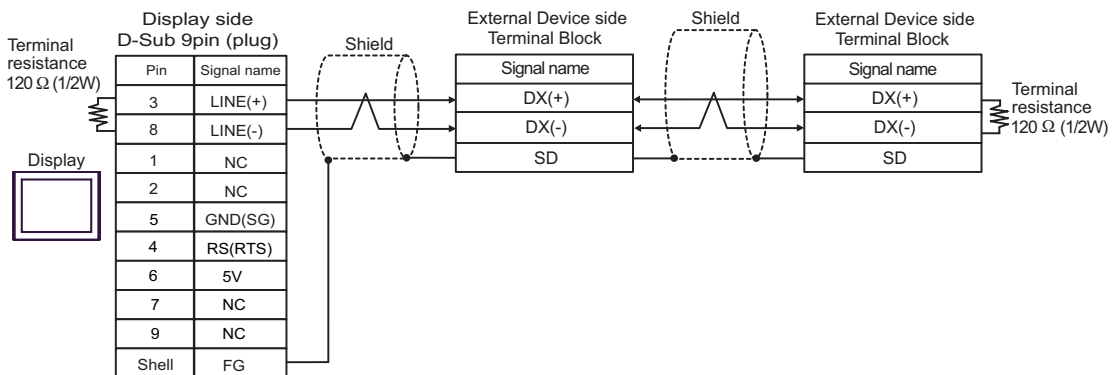

**IMPORTANT**

- The 5V output (Pin #6) on the Display is the power for the Siemens AG's PROFIBUS connector. Do not use it for other devices.

**NOTE**

- In COM on the GP-4107, the SG and FG terminals are isolated.

1l)

- 1:1 Connection

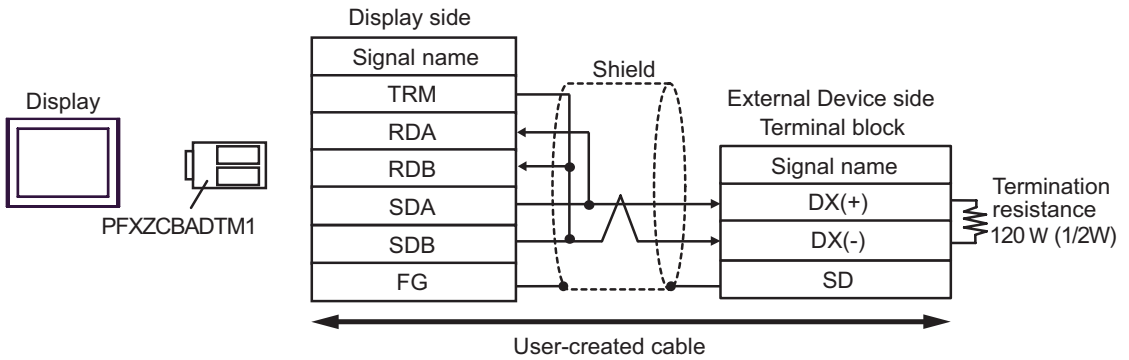

- 1:n Connection

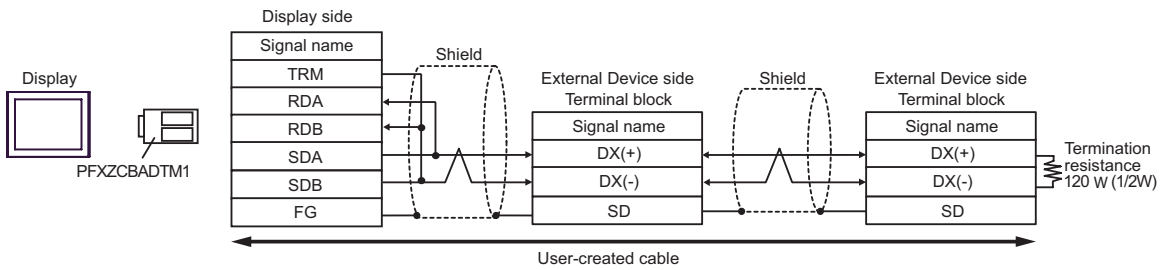

1J)

- 1:1 Connection

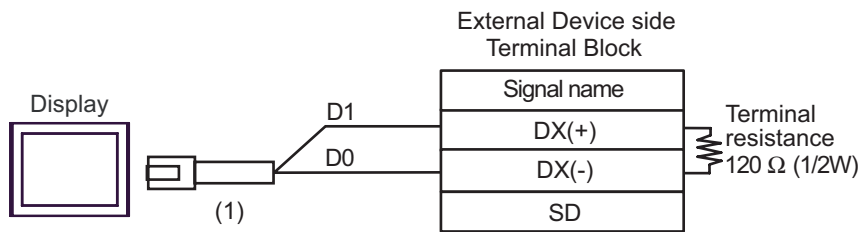

- 1:n Connection

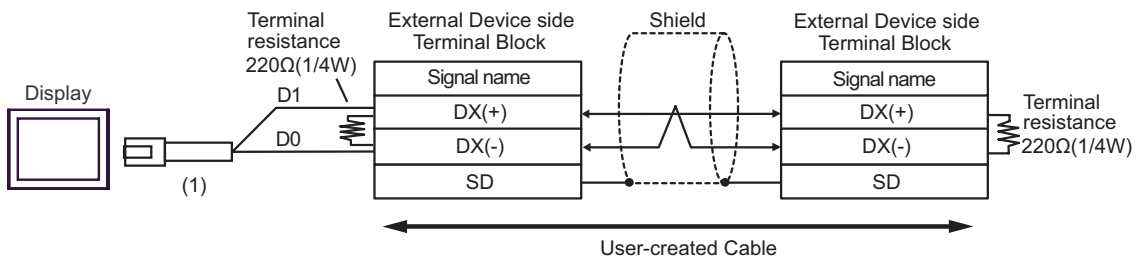

Number	Name	Notes
(1)	RJ45 RS-485 Cable (5m) by Pro-face PFXZLMCBJR81	

Cable Diagram 2

Display (Connection Port)	Cable		Remarks
GP3000* <sup>1</sup> (COM1) AGP-3302B (COM2) GP-4*01TM (COM1) ST* <sup>2</sup> (COM2) LT3000 (COM1)	2A	COM port conversion adapter by Pro-face CA3-ADPCOM-01 + Terminal block conversion adapter by Pro-face CA3-ADPTRM-01 + User-created cable	Cable length: 500m or less
	2B	User-created cable	
GP3000* <sup>3</sup> (COM2)	2C	Online adapter by Pro-face CA4-ADPONL-01 + Terminal block conversion adapter by Pro-face CA3-ADPTRM-01 + User-created cable	
	2D	Online adapter by Pro-face CA4-ADPONL-01 + User-created cable	
IPC* <sup>4</sup>	2E	COM port conversion adapter by Pro-face CA3-ADPCOM-01 + Terminal block conversion adapter by Pro-face CA3-ADPTRM-01 + User-created cable	
	2F	User-created cable	
GP-4106 (COM1)	2G	User-created cable	
GP-4107 (COM1) GP-4*03T* <sup>5</sup> (COM2) GP-4203T (COM1)	2H	User-created cable	
GP4000* <sup>6</sup> (COM2) GP-4201T (COM1)	2I	RS-422 Terminal Block Conversion Adapter by Pro-face PFXZCBADTM1* <sup>7</sup> + User-created cable	
	2B	User-created cable	
LT-4*01TM (COM1)	2J	RJ45 RS-485 Cable (5m) by Pro-face PFXZLMCBJR81	

\*1 All GP3000 models except AGP-3302B

\*2 All ST models except AST-3211A and AST-3302B

\*3 All GP3000 models except the GP-3200 Series and AGP-3302B

\*4 Only a COM port which can communicate by RS-422/485 (2-wire) can be used.

 ■ IPC COM Port (page 5)

- \*5 Except GP-4203T
- \*6 All GP4000 models except GP-4100 Series, GP-4\*01TM, GP-4201T and GP-4\*03T
- \*7 When using a Terminal Block Conversion Adapter (CA3-ADPTRM-01) instead of the RS-422 Terminal Block Conversion Adapter, refer to Cable Diagram 2A.

- The following cables are recommended as the connecting cable for use with RJ-45 connectors.

Part name	Model	Remarks
Extension cable by Fuji Electric Systems Co., Ltd.	CB-5S, CB-3S, CB-1S	3 cables available in length of 5m, 3m, and 1m.

When using an off-the-shelf LAN cable, use a 10BASE-T/100BASE-TX straight type cable (less than 20m) compliant to US ANSI TIA/EIA-568A Category 5.

The recommended LAN cables are KB-10T5-01K (1m) and KB-STP-01K (1m) (Shielded LAN cable compliant with EMC Directive) by SANWA Supply Co., Ltd.

- The recommended connection cable between the terminal block of the Display side and the RJ-45 connector is the Furukawa Electric's AWM2789 long-distance cable.
- Set the termination resistance switch on the External Device as follows:

Series	Switch	Setting
FVR-E11S	SW2	ON
FRENIC-MEGA	SW3	ON
FRENIC-Mini OPC-C1-RS card	SW1	ON
FRENIC-Eco	SW3	ON
FRENIC-Multi	SW3	ON

- RJ-45 connector pin numbers differ depending on the External Device series.

The following pin numbers correspond to each series. Refer to your External Device manual for details.

Pin No.	FRENIC-MEGA FRENIC-Mini FRENIC-Eco FRENIC-Multi	FVR-E11S
1	VCC (+5V)	SEL_TP
2	GND	GND
3	NC	DX (-)
4	DX (-)	DX (+)
5	DX (+)	SEL_ANY
6	NC	GND
7	GND	VCC
8	VCC (+5V)	VCC

**IMPORTANT**

- Do not use pin numbers 1, 2, 7 and 8 of the FRENIC-MEGA, FRENIC-Mini, FRENIC-Eco, FRENIC-Multi series for communications. Refer to your External Device manual for details.
  - When using the FVR-E11S series, do not connect the VCC to the connector cables. Refer to your External Device manual for details.
-

2A)

- 1:1 Connection

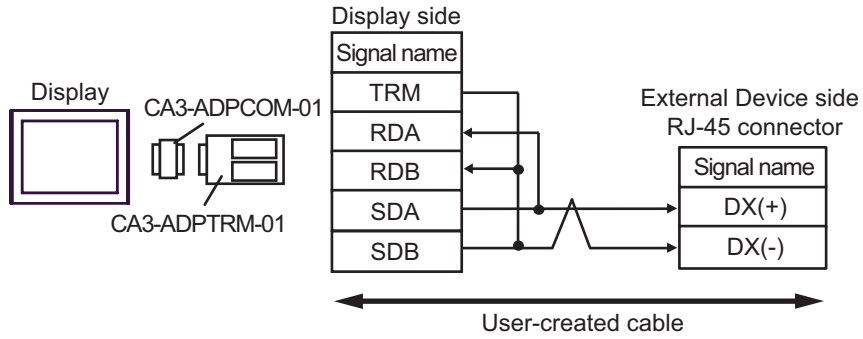

- 1:n Connection

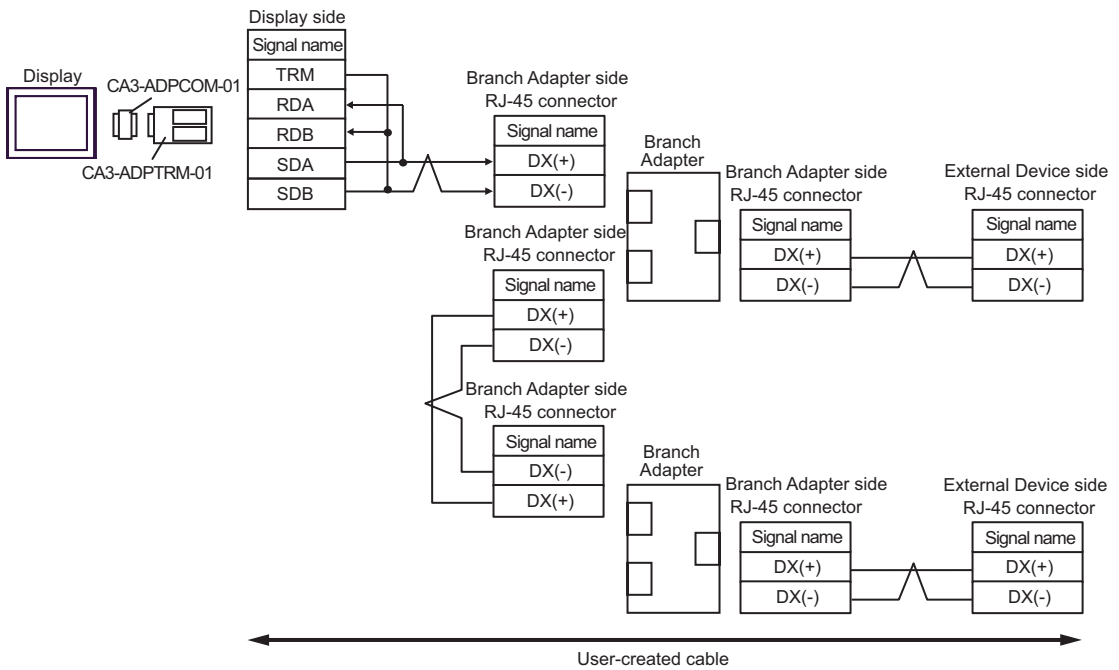

**NOTE**

- For 1:n connection, set the termination resistance switch on the External Device located at the end to ON.
- The recommended branch adapter is the SK KOHKI's MS8-BA-JJJ.

2B)

- 1:1 Connection

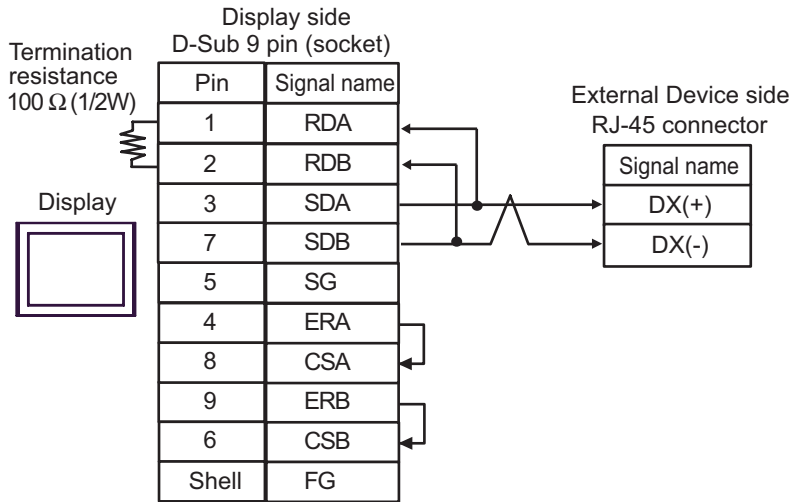

- 1:n Connection

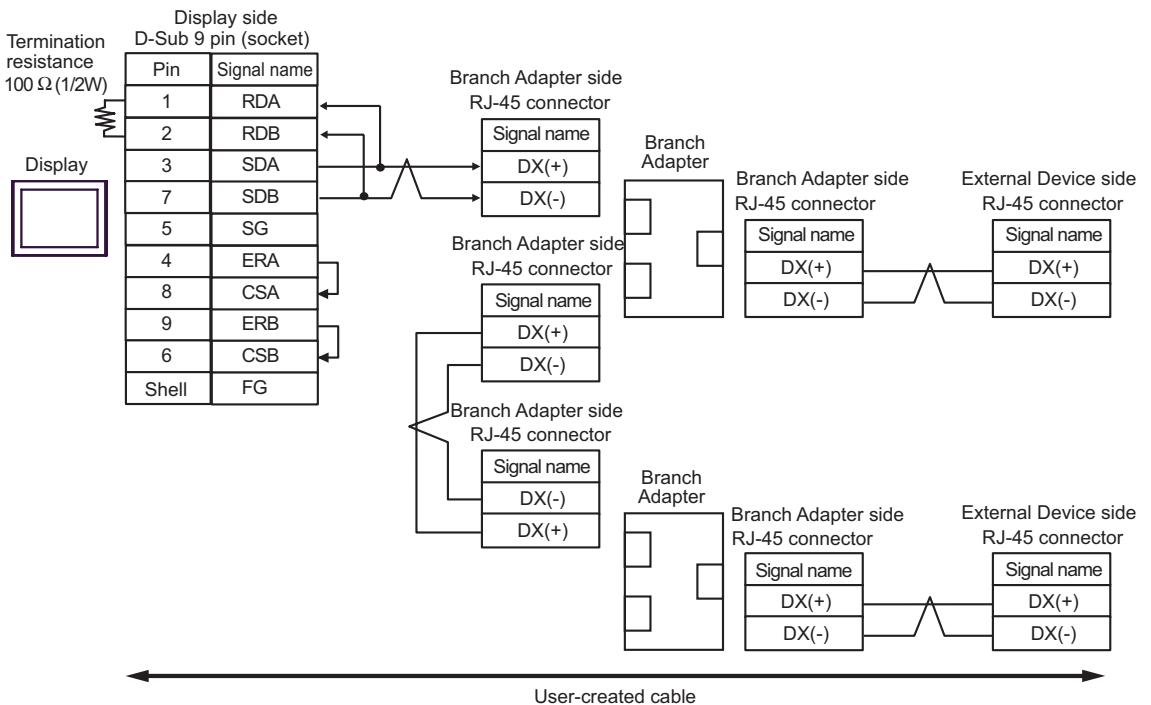

**NOTE**

- For 1:n connection, set the termination resistance switch on the External Device located at the end to ON.
- The recommended branch adapter is the SK KOHKI's MS8-BA-JJJ.



2C)

- 1:1 Connection

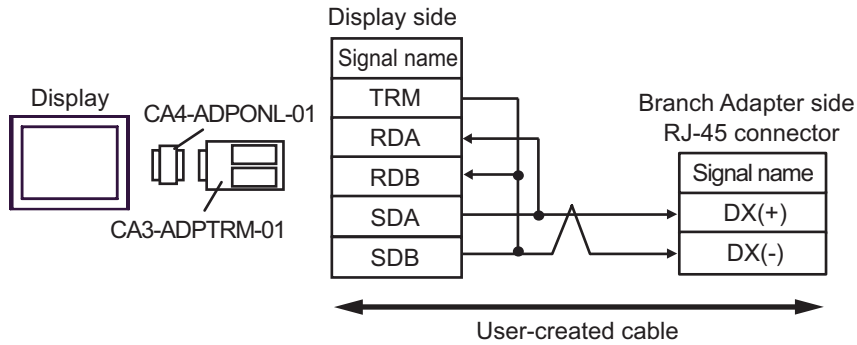

- 1:n Connection

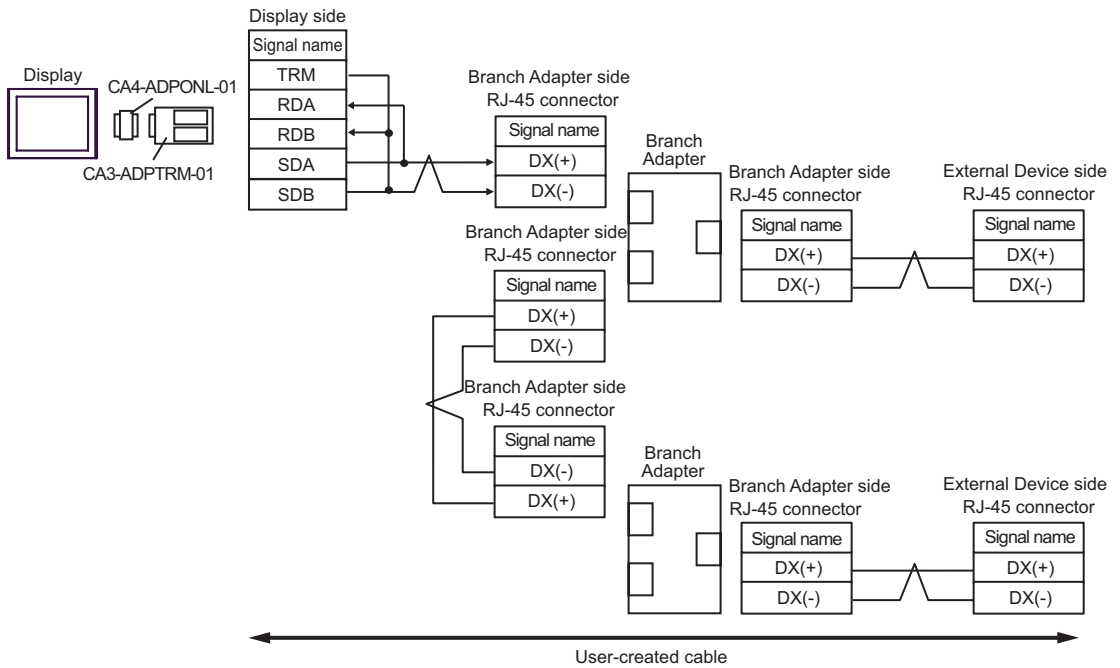

**NOTE**

- For 1:n connection, set the termination resistance switch on the External Device located at the end to ON.
- The recommended branch adapter is the SK KOHKI's MS8-BA-JJJ.

2D)

- 1:1 Connection

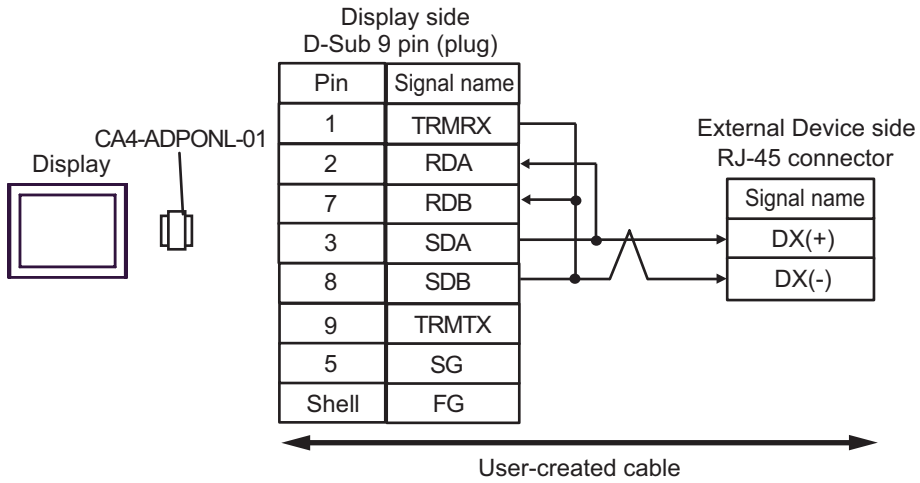

- 1:n Connection

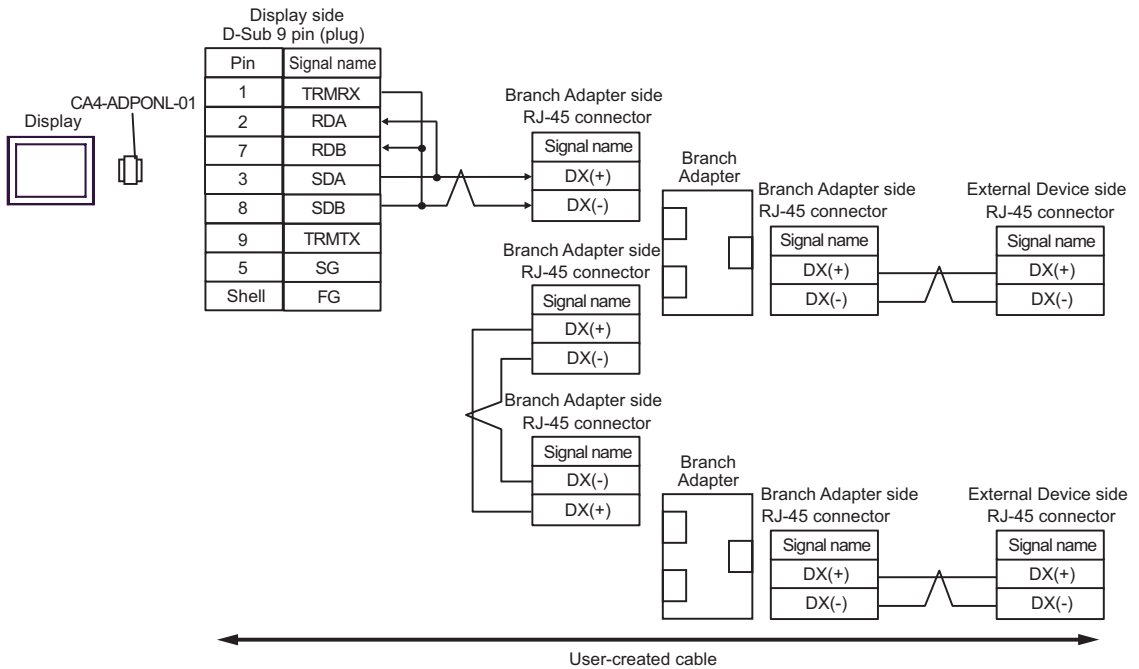

**NOTE**

- For 1:n connection, set the termination resistance switch on the External Device located at the end to ON.
- The recommended branch adapter is the SK KOHKI's MS8-BA-JJJ.

2E)

- 1:1 Connection

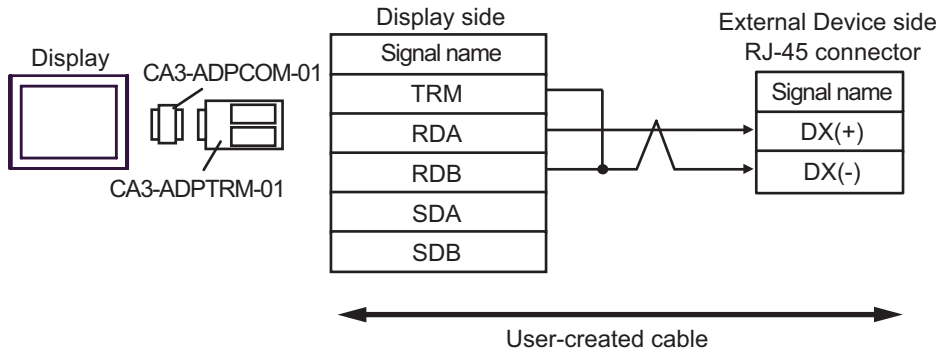

- 1:n Connection

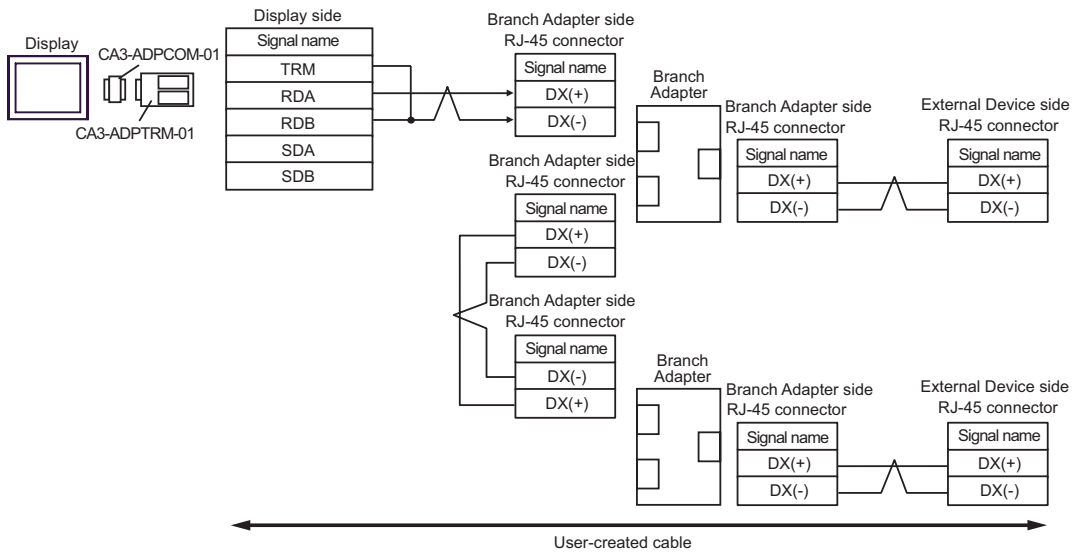

**NOTE**

- For 1:n connection, set the termination resistance switch on the External Device located at the end to ON.
- The recommended branch adapter is the SK KOHKI's MS8-BA-JJJ.

2F)

- 1:1 Connection

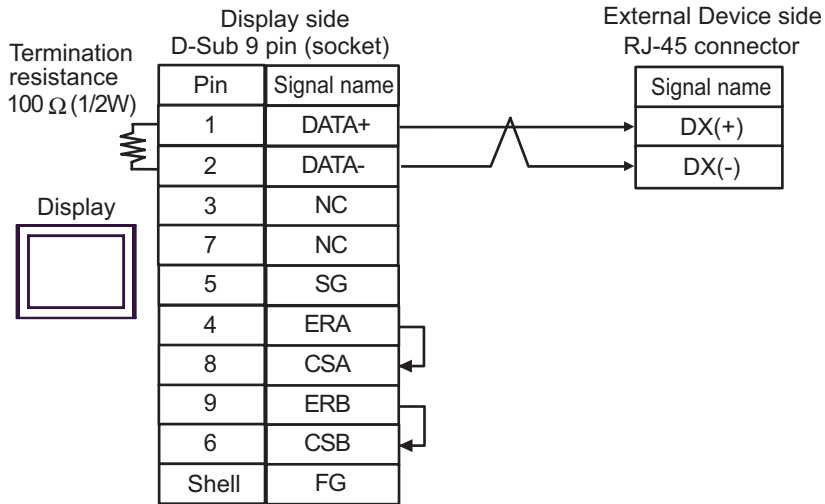

- 1:n Connection

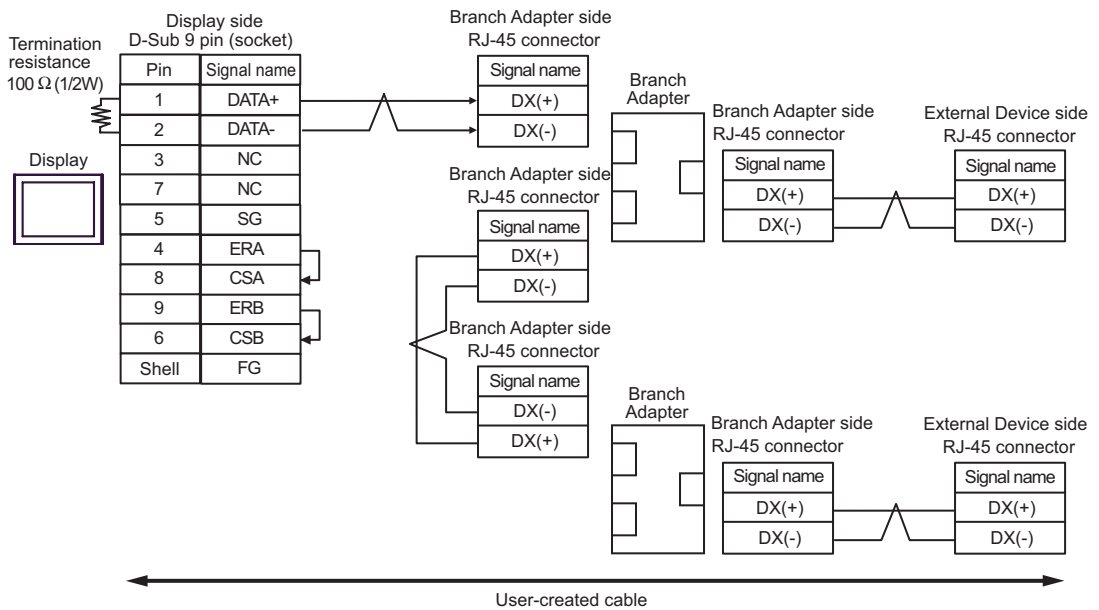

**NOTE**

- For 1:n connection, set the termination resistance switch on the External Device located at the end to ON.
- The recommended branch adapter is the SK KOHKI's MS8-BA-JJJ.

2G)

- 1:1 Connection

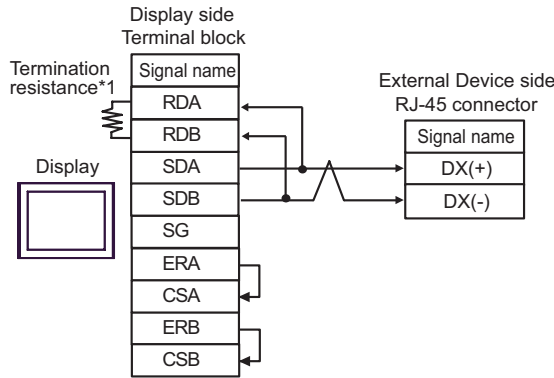

- 1:n Connection

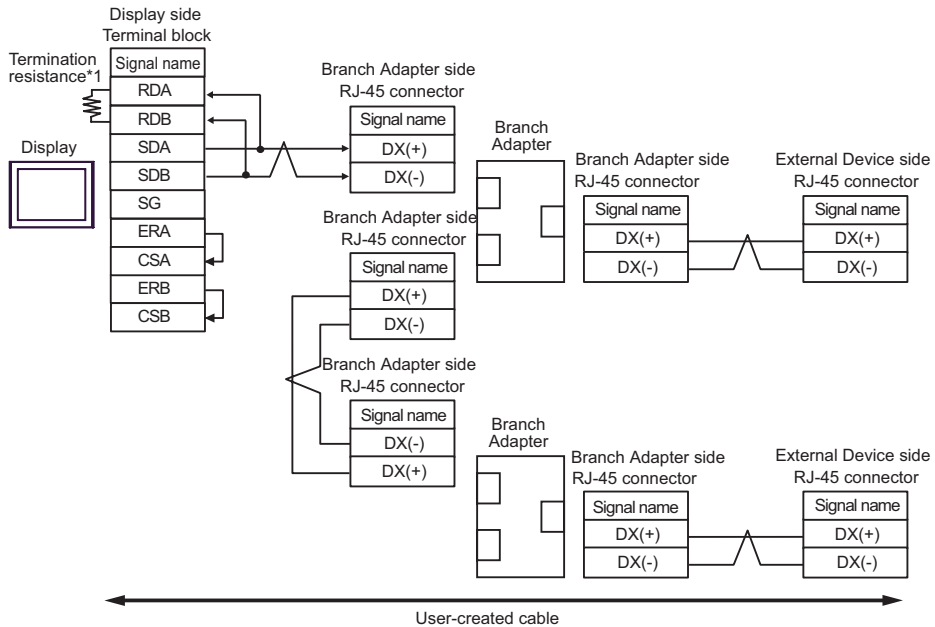

**NOTE**

- For 1:n connection, set the termination resistance switch on the External Device located at the end to ON.
- The recommended branch adapter is the SK KOHKI's MS8-BA-JJJ.

\*1 The resistance in the Display is used as the termination resistance. Set the value of the DIP Switch on the rear of the Display as shown in the table below.

DIP Switch No.	Set Value
1	OFF
2	OFF
3	ON
4	ON

2H)

- 1:1 Connection

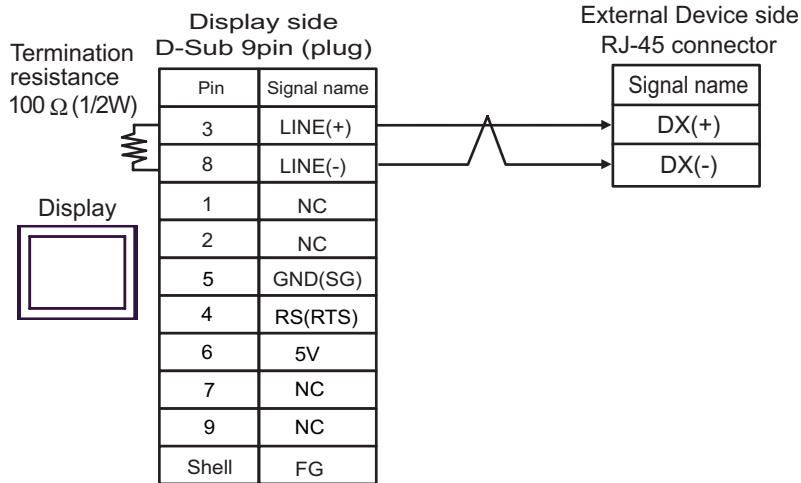

- 1:n Connection

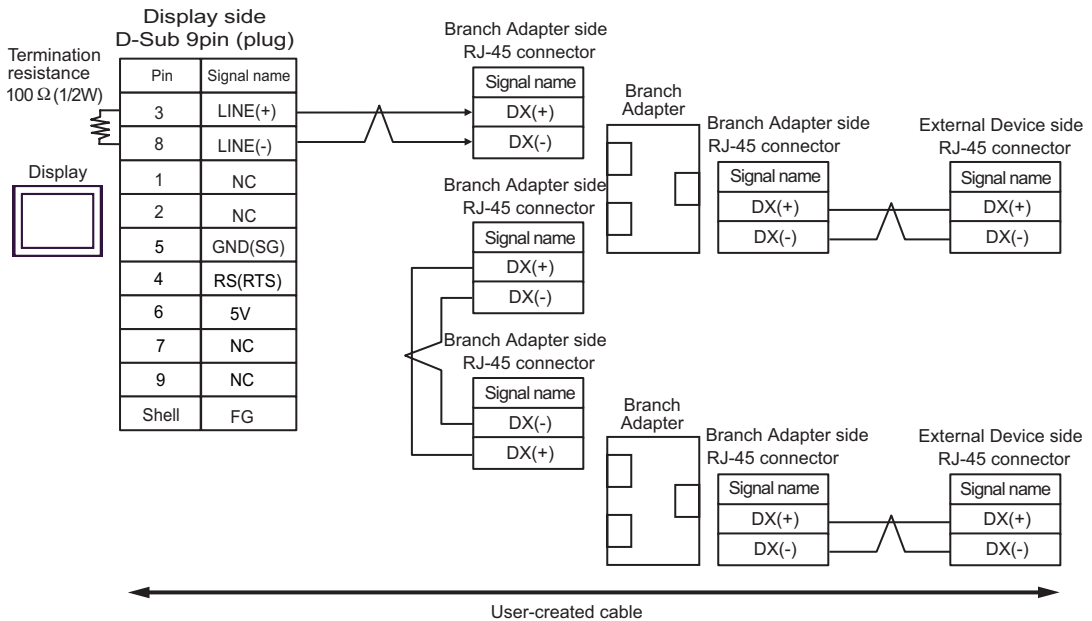

**IMPORTANT**

- The 5V output (Pin #6) on the Display is the power for the Siemens AG's PROFIBUS connector. Do not use it for other devices.

**NOTE**

- For 1:n connection, set the termination resistance switch on the External Device located at the end to ON.
- The recommended branch adapter is the SK KOHKI's MS8-BA-JJJ.
- In COM on the GP-4107, the SG and FG terminals are isolated.

2l)

- 1:1 Connection

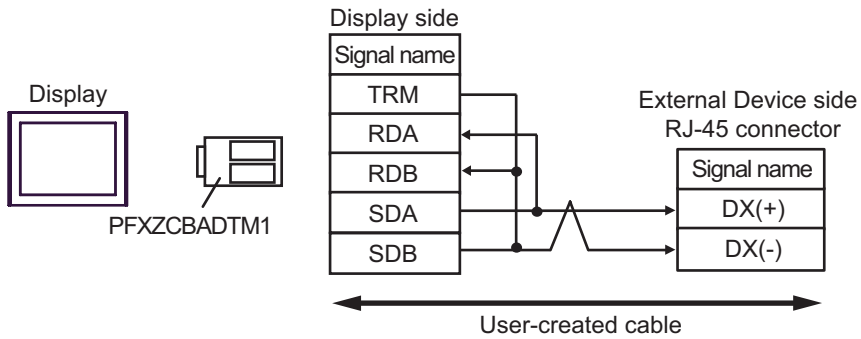

- 1:n Connection

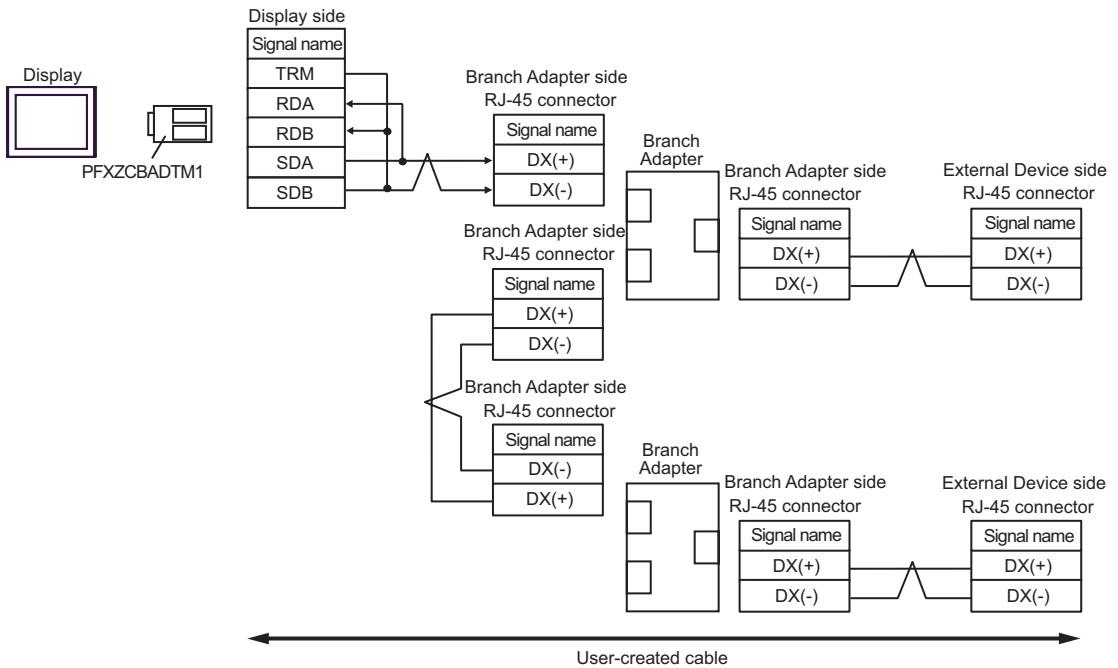

**NOTE**

- For 1:n connection, set the termination resistance switch on the External Device located at the end to ON.
- The recommended branch adapter is the SK KOHKI's MS8-BA-JJJ.

2J)

- 1:1 Connection

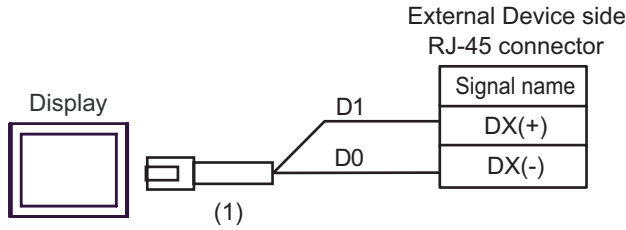

- 1:n Connection

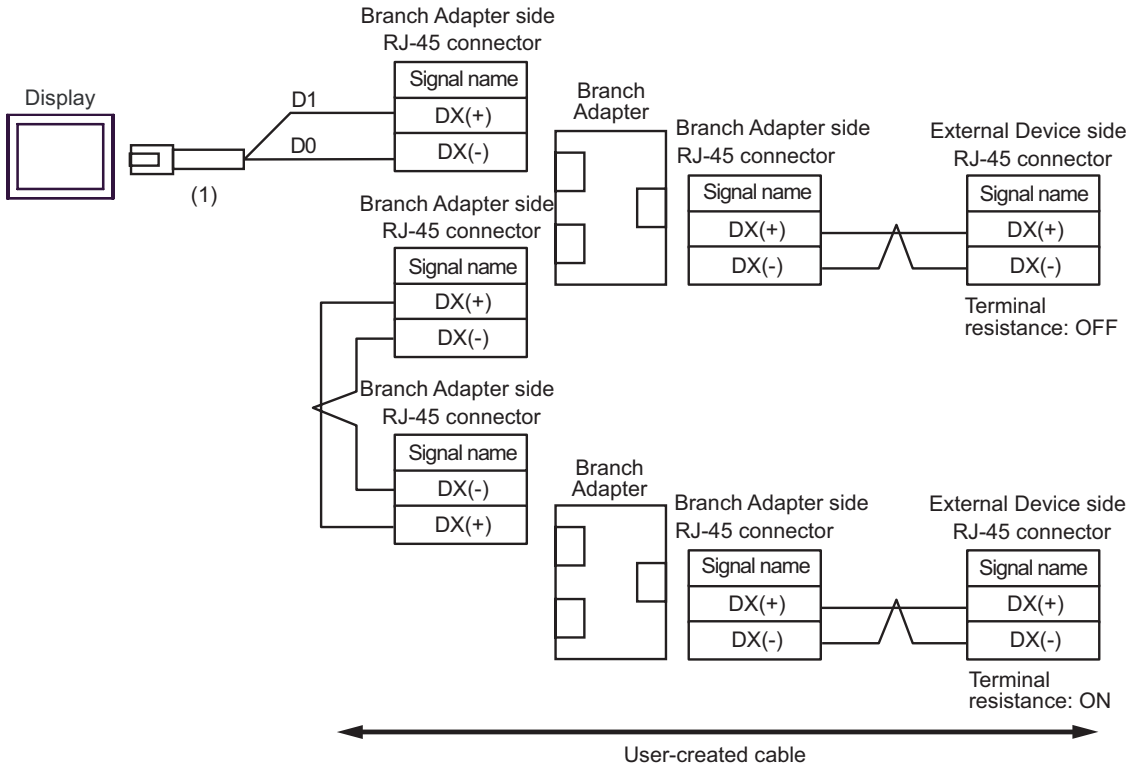

Number	Name	Notes
(1)	RJ45 RS-485 Cable (5m) by Pro-face PFXZLMCBRJR81	

**NOTE**

- For 1:n connection, set the termination resistance switch on the External Device located at the end to ON.
- The recommended branch adapter is the SK KOHKI's MS8-BA-JJJ.



Cable Diagram 3

Display (Connection Port)	Cable		Remarks
GP3000* <sup>1</sup> (COM1) AGP-3302B (COM2) GP-4*01TM (COM1) ST* <sup>2</sup> (COM2) LT3000 (COM1)	3A	COM port conversion adapter by Pro-face CA3-ADPCOM-01 + Terminal block conversion adapter by Pro-face CA3-ADPTRM-01 + User-created cable	Cable length: 500m or less
	3B	User-created cable	
GP3000* <sup>3</sup> (COM2)	3C	Online adapter by Pro-face CA4-ADPONL-01 + Terminal block conversion adapter by Pro-face CA3-ADPTRM-01 + User-created cable	
	3D	Online adapter by Pro-face CA4-ADPONL-01 + User-created cable	
IPC* <sup>4</sup>	3E	COM port conversion adapter CA3-ADPCOM-01 + Terminal block conversion adapter by Pro-face CA3-ADPTRM-01 + User-created cable	
	3F	User-created cable	
GP-4106 (COM1)	3G	User-created cable	
GP-4107 (COM1) GP-4*03T* <sup>5</sup> (COM2) GP-4203T (COM1)	3H	User-created cable	
GP4000* <sup>6</sup> (COM2) GP-4201T (COM1)	3I	RS-422 Terminal Block Conversion Adapter by Pro-face PFXZCBADTM1* <sup>7</sup> + User-created cable	
	3B	User-created cable	
LT-4*01TM (COM1)	3J	RJ45 RS-485 Cable (5m) by Pro-face PFXZLMCBJR81	

\*1 All GP3000 models except AGP-3302B

\*2 All ST models except AST-3211A and AST-3302B

\*3 All GP3000 models except the GP-3200 Series and AGP-3302B

\*4 Only a COM port which can communicate by RS-422/485 (2-wire) can be used.

 ■ IPC COM Port (page 5)

- \*5 Except GP-4203T
- \*6 All GP4000 models except GP-4100 Series, GP-4\*01TM, GP-4201T and GP-4\*03T
- \*7 When using a Terminal Block Conversion Adapter (CA3-ADPTRM-01) instead of the RS-422 Terminal Block Conversion Adapter, refer to Cable Diagram 3A.

- The recommended connection cable is the Furukawa Electric's AWM2789 long-distance cable.
- Set the termination resistance switch on the External Device as follows:

Series	Switch	Setting
FRENIC-MEGA	SW2	ON
FRENIC-Eco OPC-F1-RS card	SW103	ON

**IMPORTANT**

- Depending on the operating environment, malfunctions may occur due to External Device noise. In this case, connect the ferrite core to the cable.

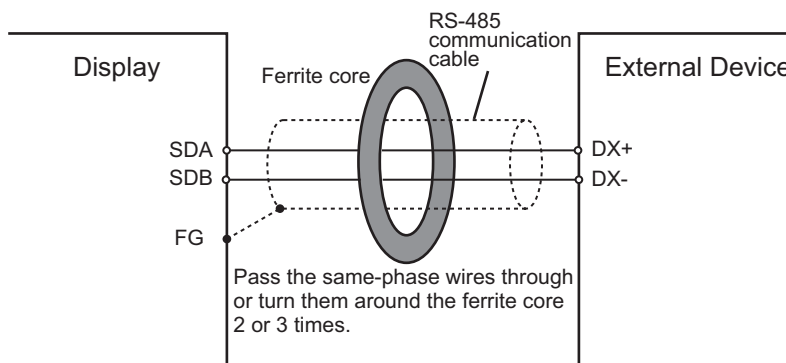

3A)

- 1:1 Connection

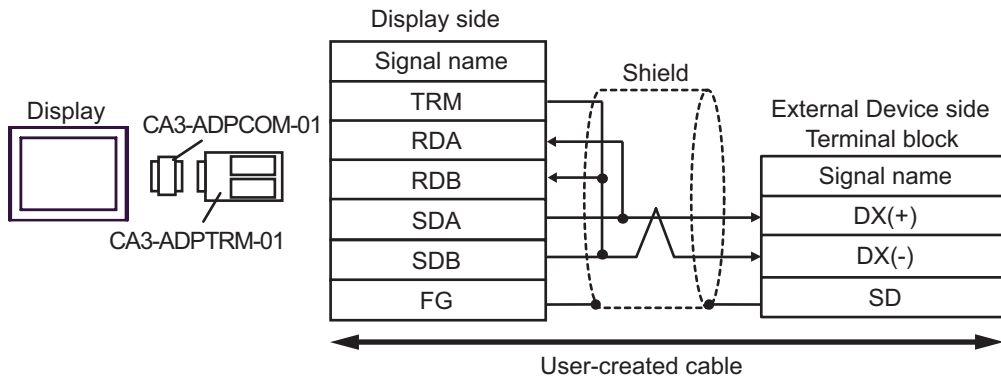

- 1:n Connection

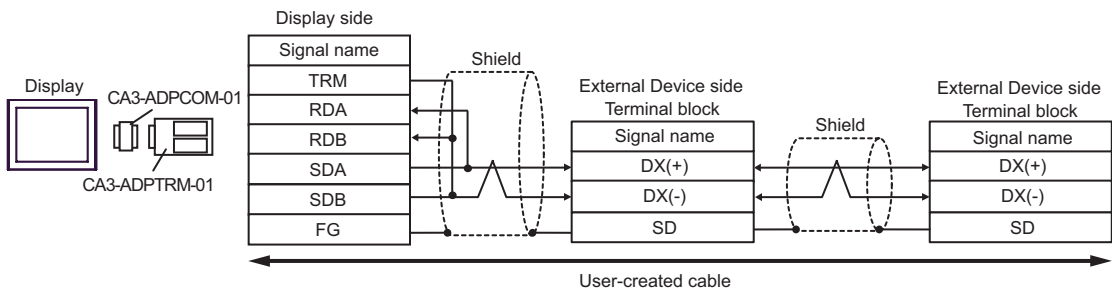

**NOTE**

- For 1:n connection, set the termination resistance switch on the External Device located at the end to ON.

3B)

- 1:1 Connection

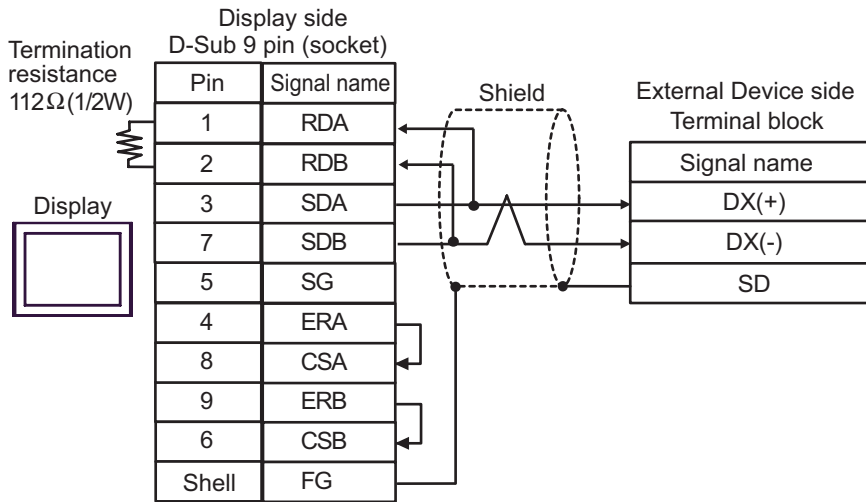

- 1:n Connection

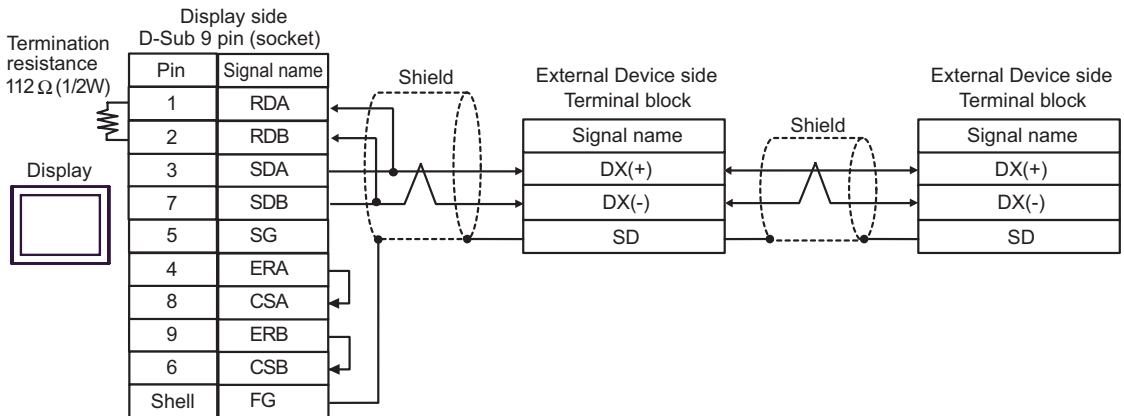

**NOTE**

- For 1:n connection, set the termination resistance switch on the External Device located at the end to ON.

3C)

- 1:1 Connection

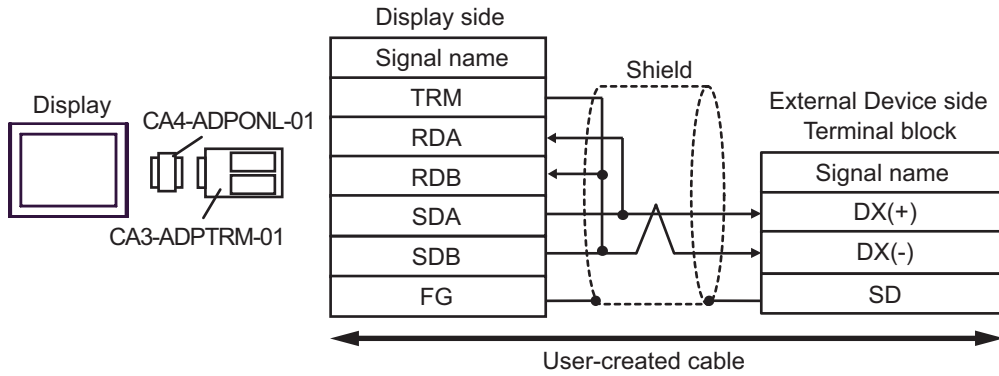

- 1:n Connection

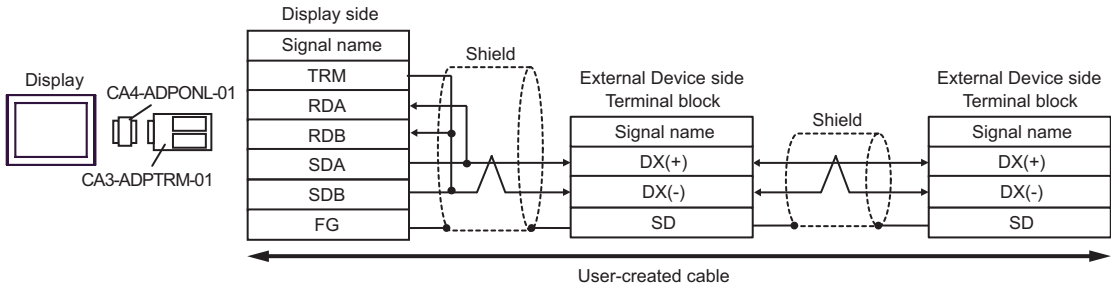

**NOTE**

- For 1:n connection, set the termination resistance switch on the External Device located at the end to ON.

3D)

- 1:1 Connection

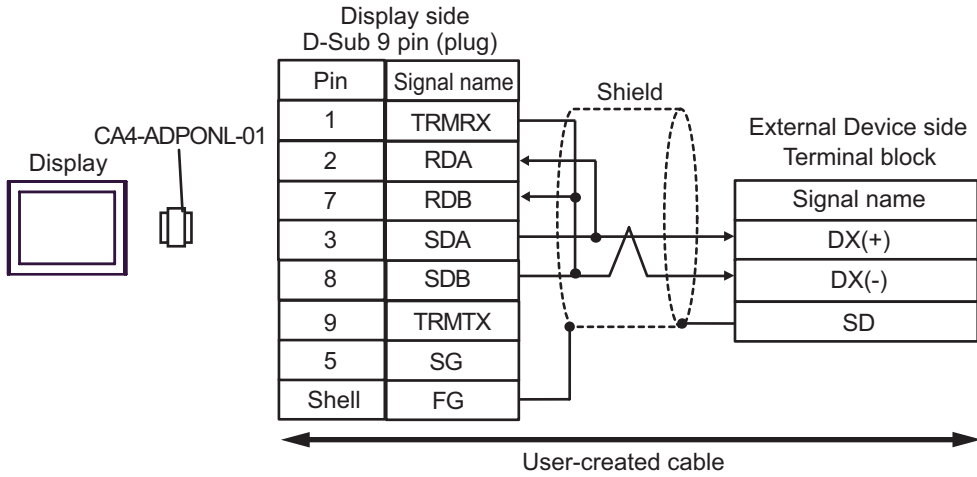

- 1:n Connection

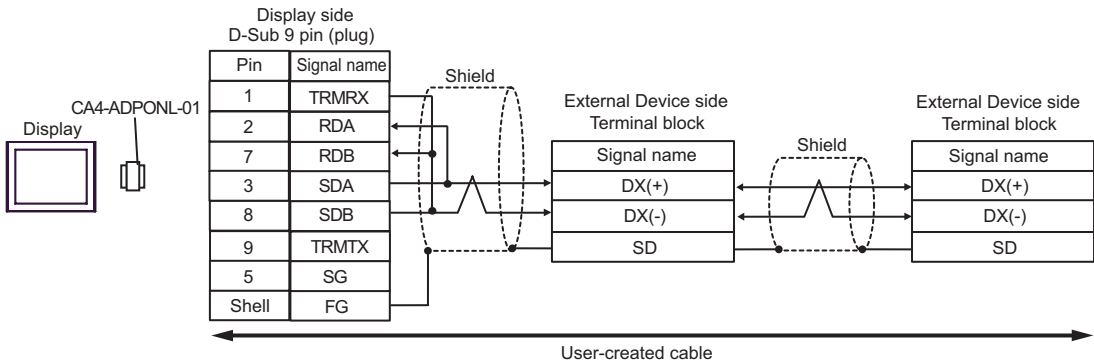

**NOTE**

- For 1:n connection, set the termination resistance switch on the External Device located at the end to ON.

3E)

- 1:1 Connection

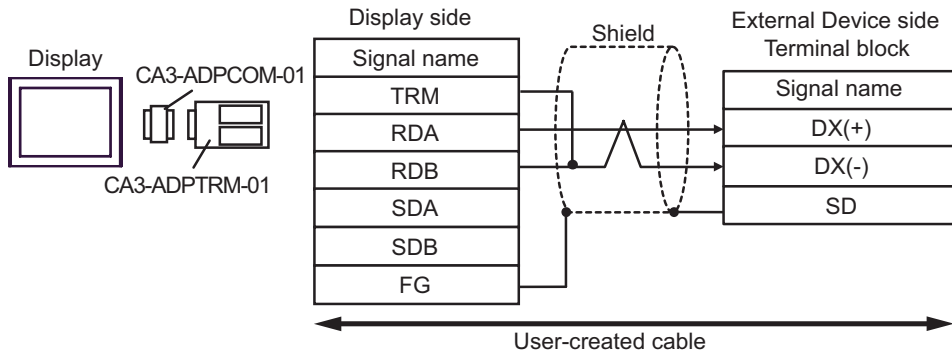

- 1:n Connection

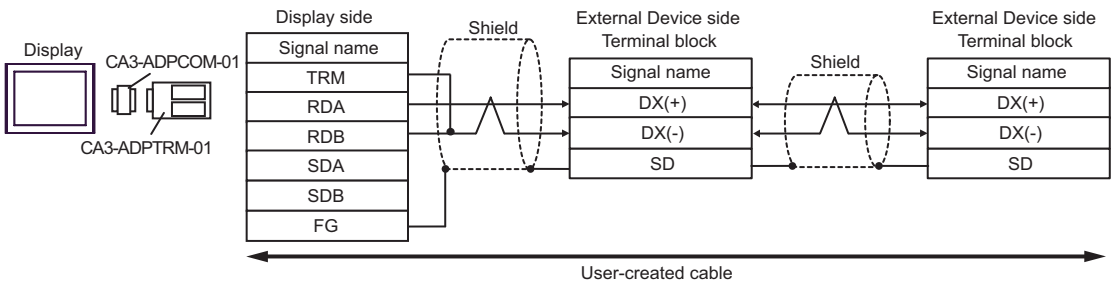

**NOTE**

- For 1:n connection, set the termination resistance switch on the External Device located at the end to ON.

3F)

- 1:1 Connection

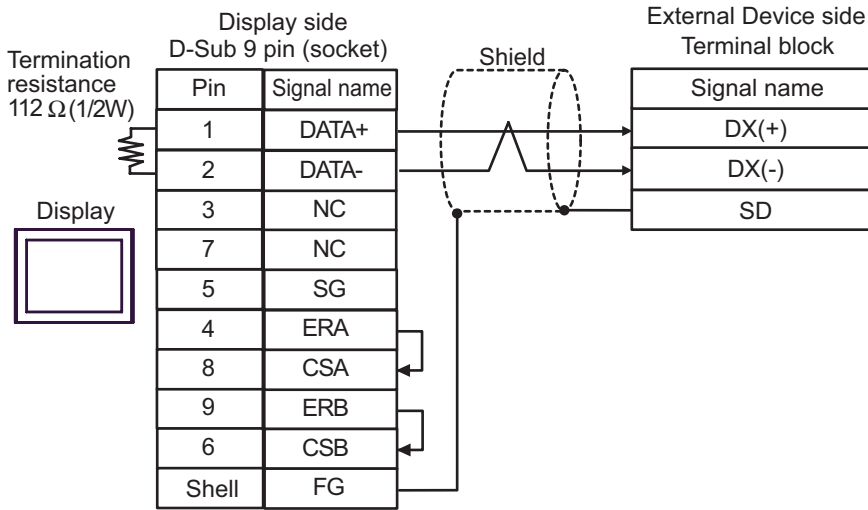

- 1:n Connection

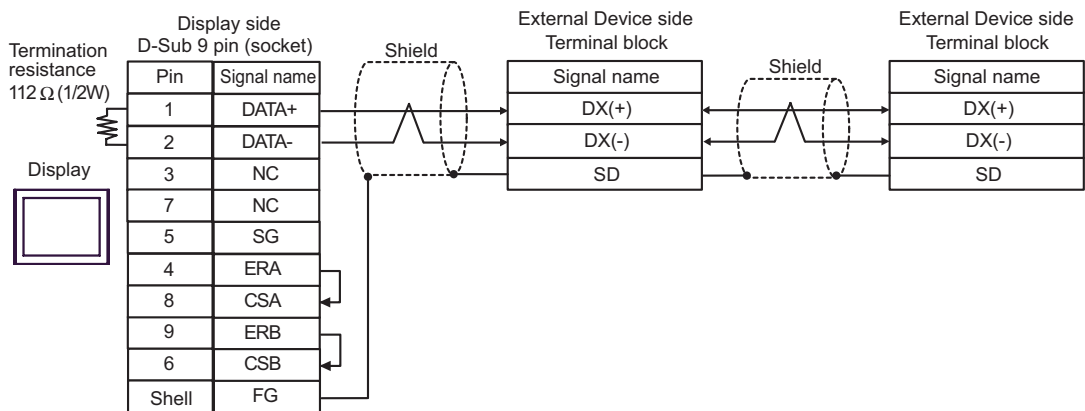

**NOTE**

- For 1:n connection, set the termination resistance switch on the External Device located at the end to ON.



3G)

- 1:1 Connection

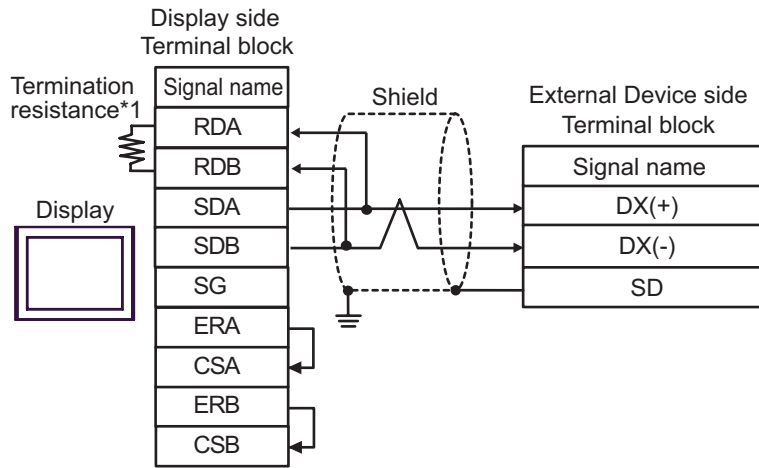

- 1:n Connection

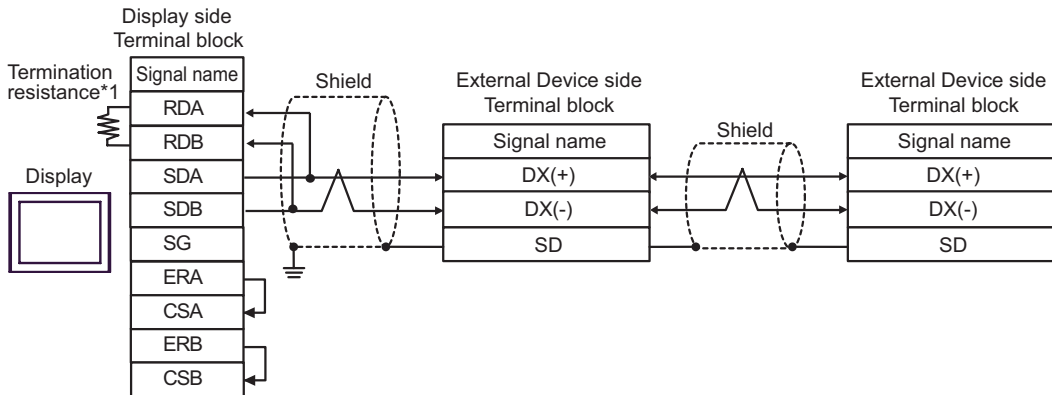

**NOTE**

- For 1:n connection, set the termination resistance switch on the External Device located at the end to ON.

\*1 The resistance in the Display is used as the termination resistance. Set the value of the DIP Switch on the rear of the Display as shown in the table below.

DIP Switch No.	Set Value
1	OFF
2	OFF
3	ON
4	ON

3H)

- 1:1 Connection

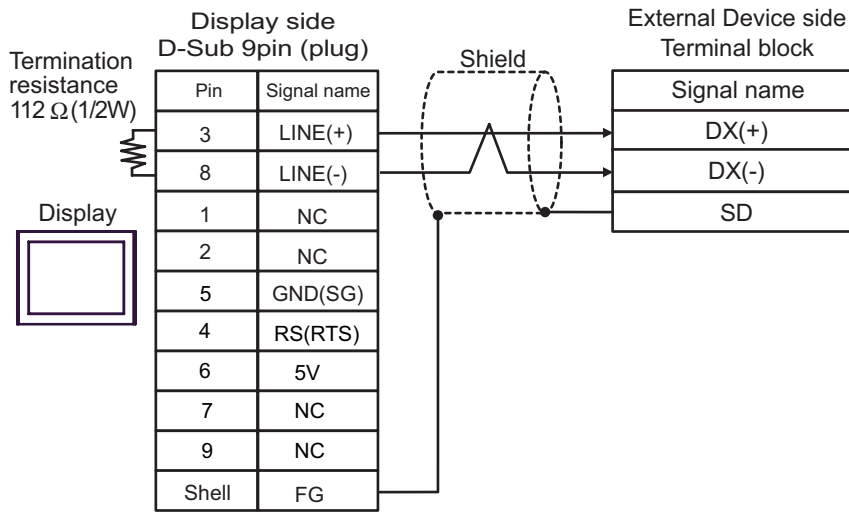

- 1:n Connection

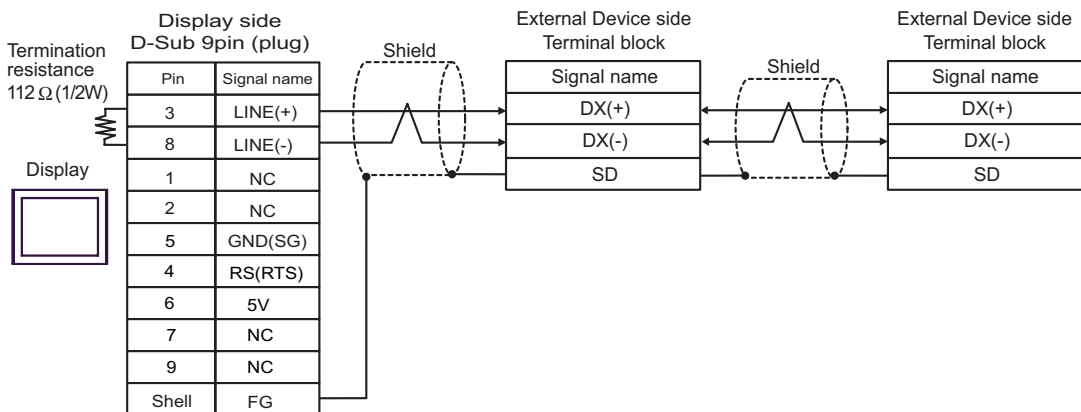

**IMPORTANT** • The 5V output (Pin #6) on the Display is the power for the Siemens AG's PROFIBUS connector. Do not use it for other devices.

**NOTE** • For 1:n connection, set the termination resistance switch on the External Device located at the end to ON.  
 • In COM on the GP-4107, the SG and FG terminals are isolated.

3l)

- 1:1 Connection

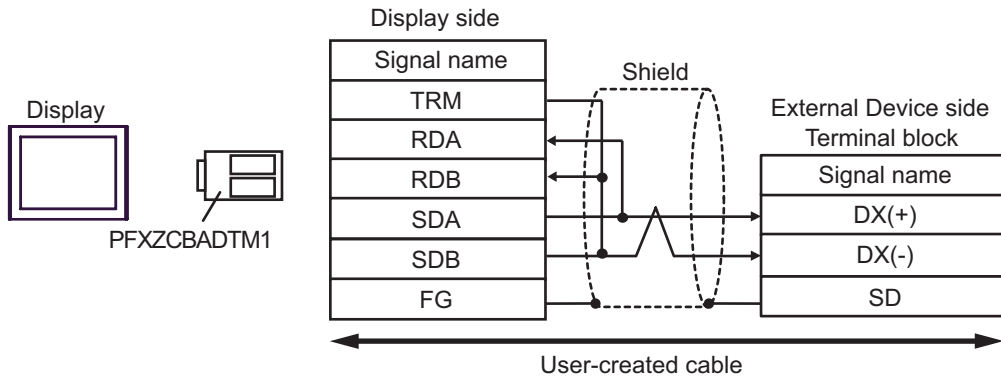

- 1:n Connection

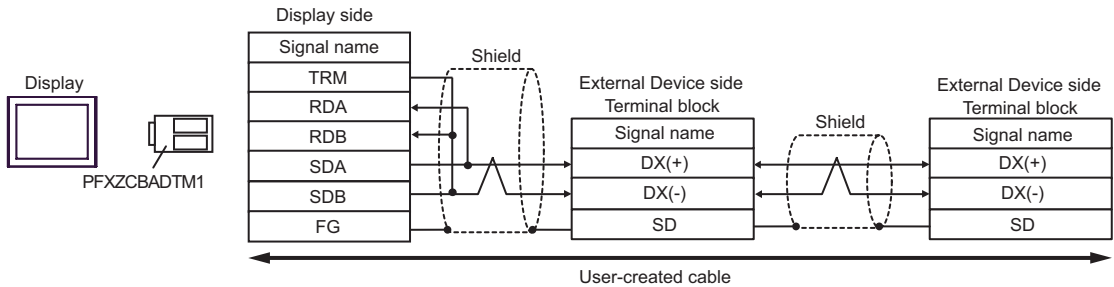

**NOTE**

- For 1:n connection, set the termination resistance switch on the External Device located at the end to ON.

3J)

- 1:1 Connection

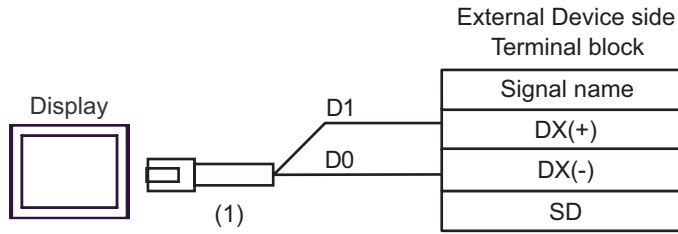

- 1:n Connection

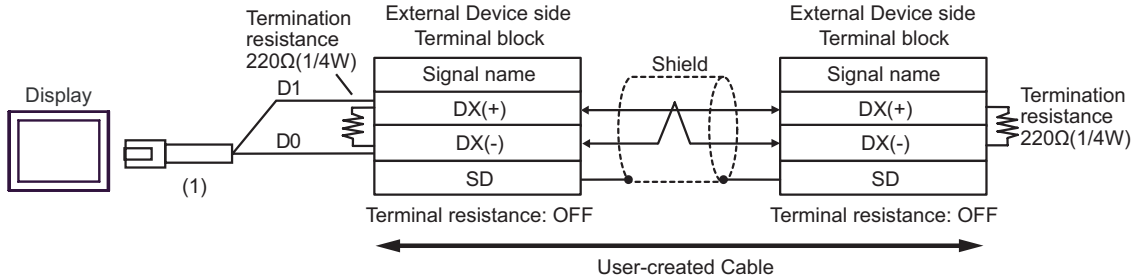

Number	Name	Notes
(1)	RJ45 RS-485 Cable (5m) by Pro-face PFXZLMCBJR81	

Cable Diagram 4

Display (Connection Port)	Cable		Remarks
GP3000* <sup>1</sup> (COM1) AGP-3302B (COM2) GP-4*01TM (COM1) ST* <sup>2</sup> (COM2) LT3000 (COM1)	4A	COM port conversion adapter by Pro-face CA3-ADPCOM-01 + Terminal block conversion adapter by Pro-face CA3-ADPTRM-01 + User-created cable	Cable length: 500m or less
	4B	User created cable	
GP3000* <sup>3</sup> (COM2)	4C	Online adapter by Pro-face CA4-ADPONL-01 + Terminal block conversion adapter by Pro-face CA3-ADPTRM-01 + User-created cable	
	4D	Online adapter by Pro-face CA4-ADPONL-01 + User-created cable	
IPC* <sup>4</sup>	4E	COM port conversion adapter by Pro-face CA3-ADPCOM-01 + Terminal block conversion adapter by Pro-face CA3-ADPTRM-01 + User-created cable	
	4F	User-created cable	
GP-4106 (COM1)	4G	User created cable	
GP-4107 (COM1) GP-4*03T* <sup>5</sup> (COM2) GP-4203T (COM1)	4H	User-created cable	
GP4000* <sup>6</sup> (COM2) GP-4201T (COM1)	4I	RS-422 Terminal Block Conversion Adapter by Pro-face PFXZCBADTM1* <sup>7</sup> + User-created cable	
	4B	User-created cable	
LT-4*01TM (COM1)	4J	RJ45 RS-485 Cable (5m) by Pro-face PFXZLMCBJR81	

\*1 All GP3000 models except AGP-3302B

\*2 All ST models except AST-3211A and AST-3302B

\*3 All GP3000 models except the GP-3200 Series and AGP-3302B

\*4 Only a COM port which can communicate by RS-422/485 (2-wire) can be used.

 ■ IPC COM Port (page 5)

- \*5 Except GP-4203T
- \*6 All GP4000 models except GP-4100 Series, GP-4\*01TM, GP-4201T and GP-4\*03T
- \*7 When using a Terminal Block Conversion Adapter (CA3-ADPTRM-01) instead of the RS-422 Terminal Block Conversion Adapter, refer to Cable Diagram 4A.
  - The recommended connection cable is the Furukawa Electric's AWM2789 long-distance cable.

4A)

- 1:1 Connection

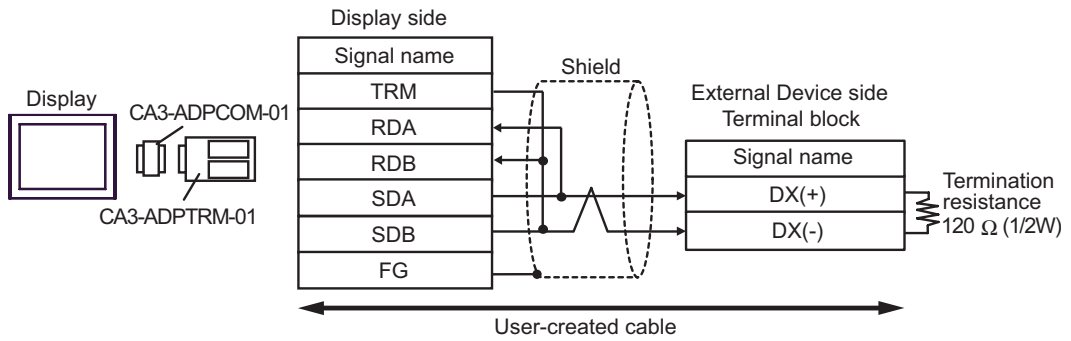

- 1:n Connection

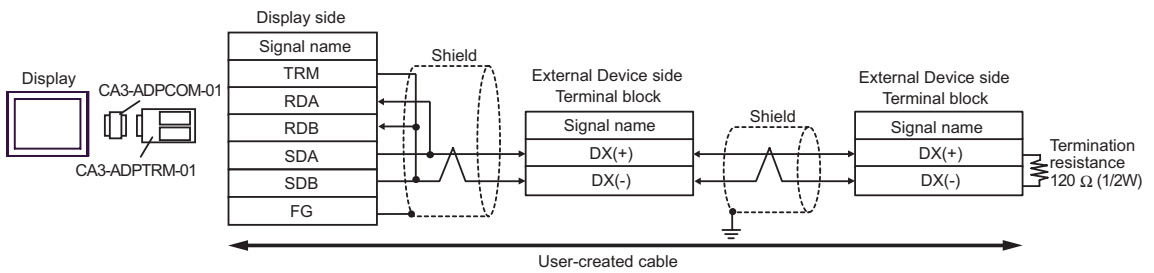

4B)

- 1:1 Connection

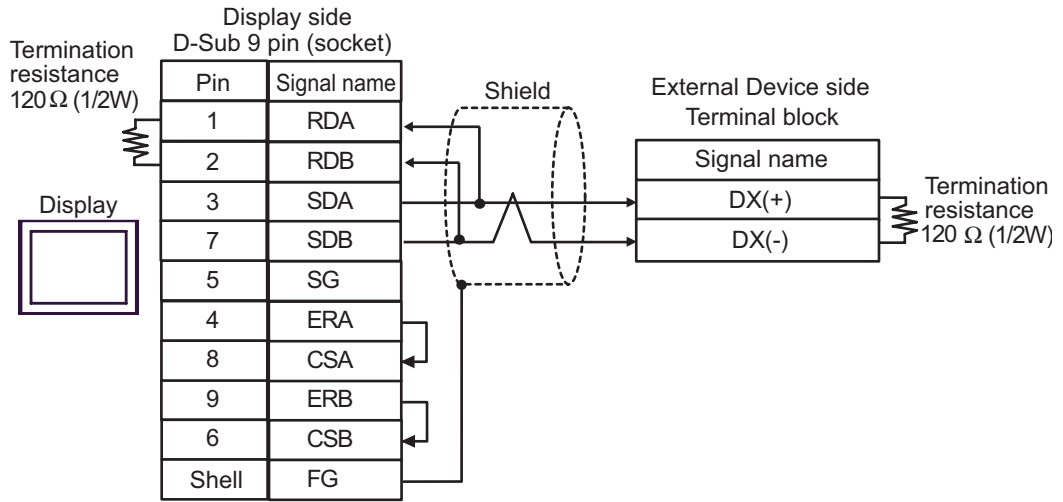

- 1:n Connection

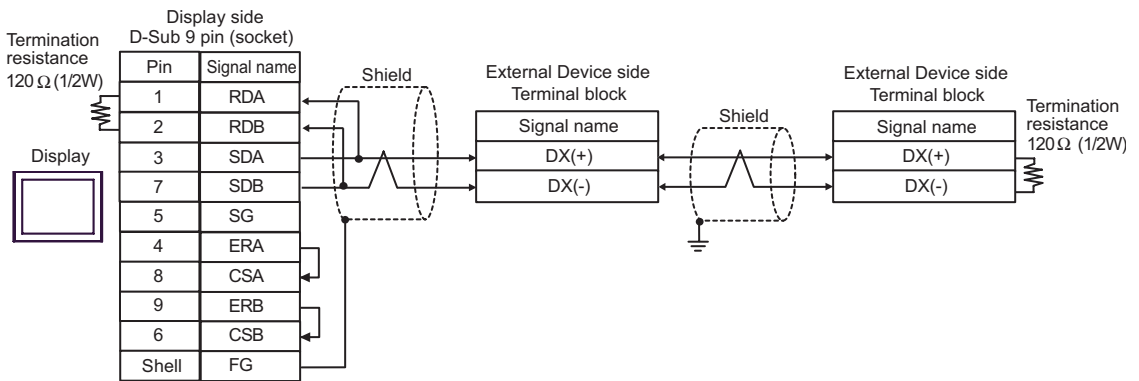



4C)

- 1:1 Connection

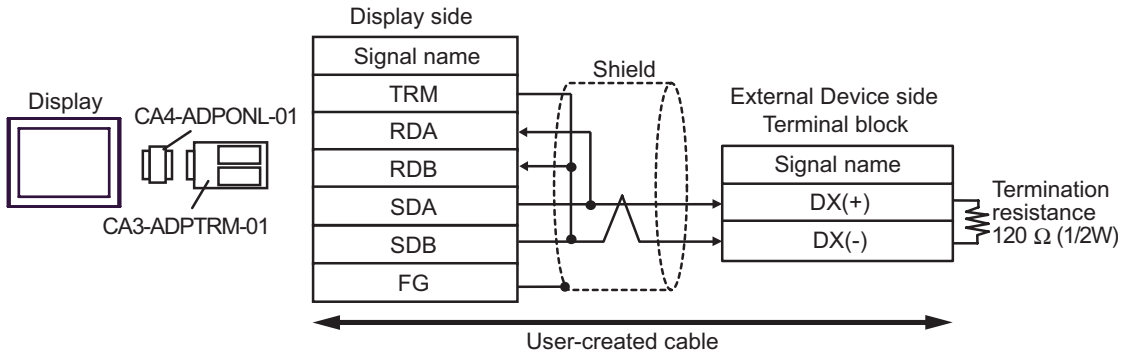

- 1:n Connection

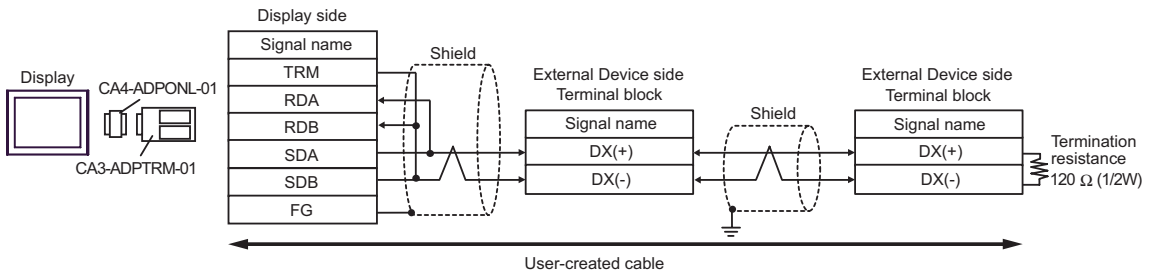

4D)

- 1:1 Connection

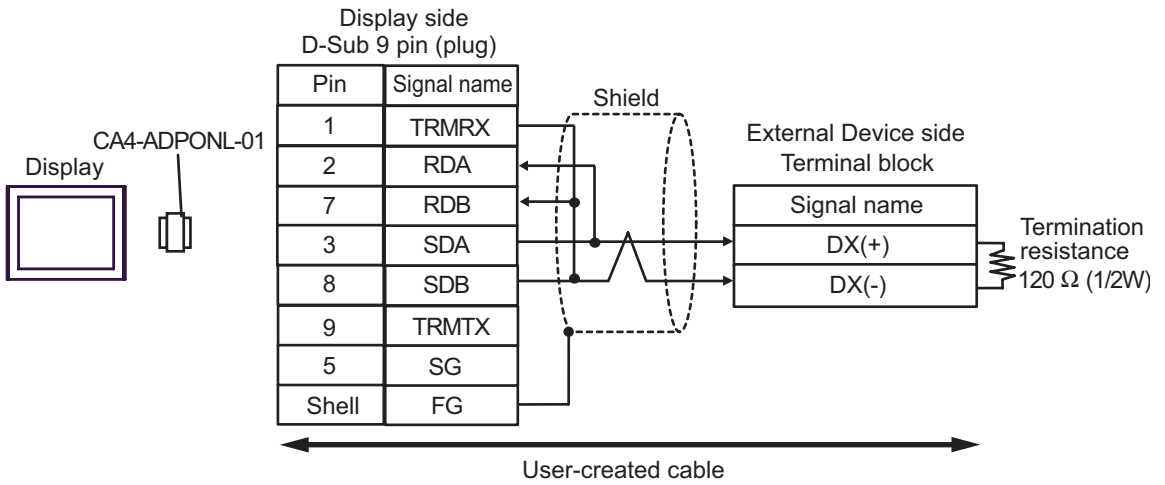

- 1:n Connection

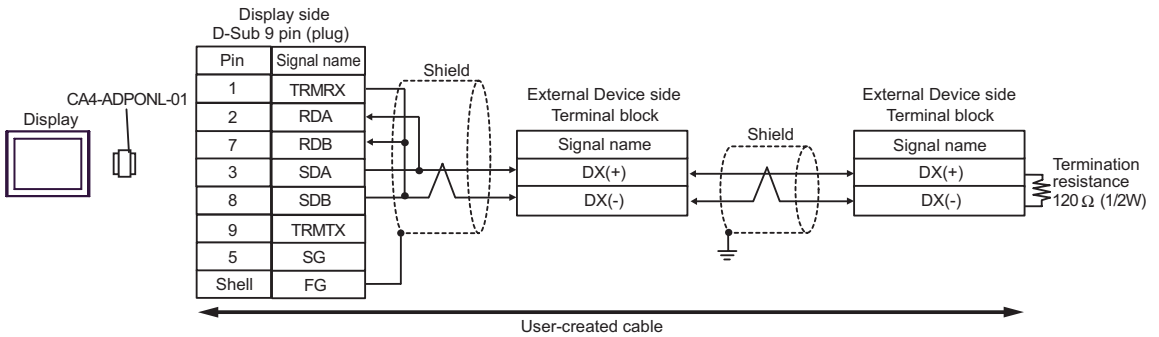

4E)

- 1:1 Connection

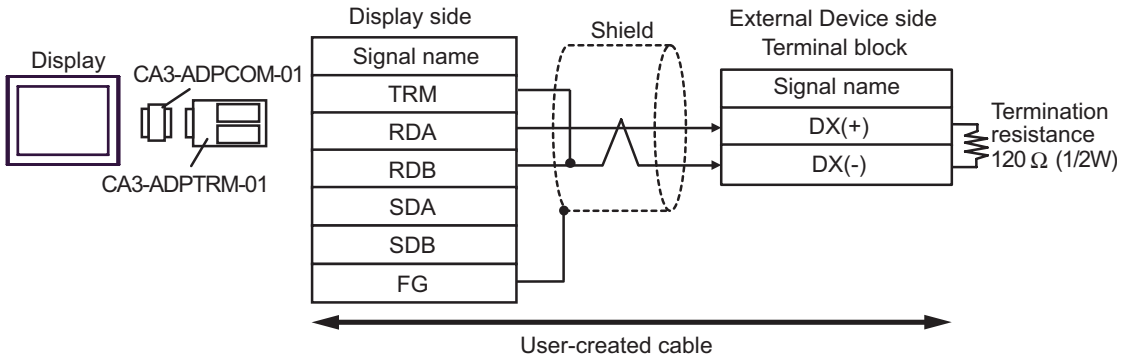

- 1:n Connection

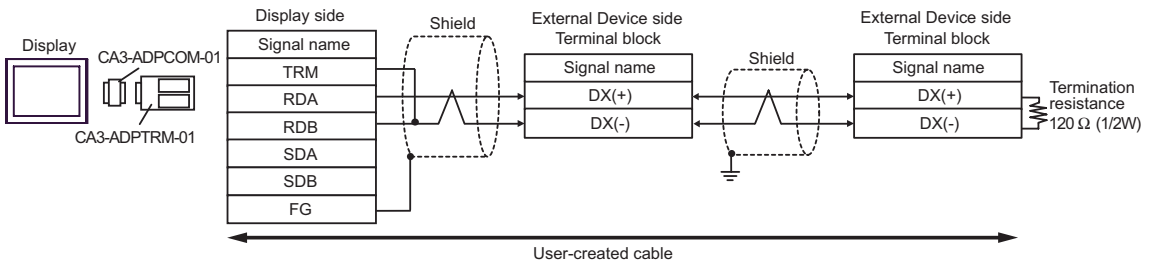

4F)

- 1:1 Connection

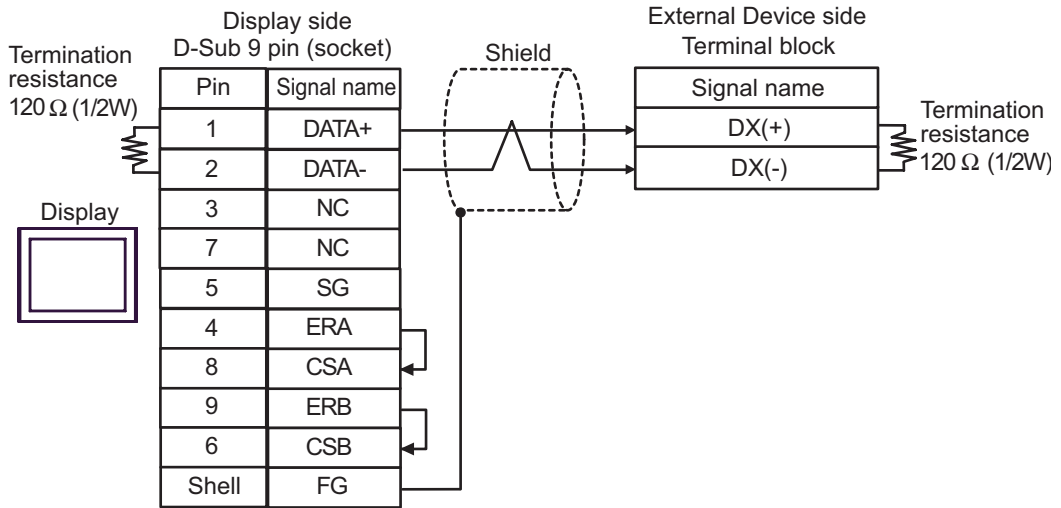

- 1:n Connection

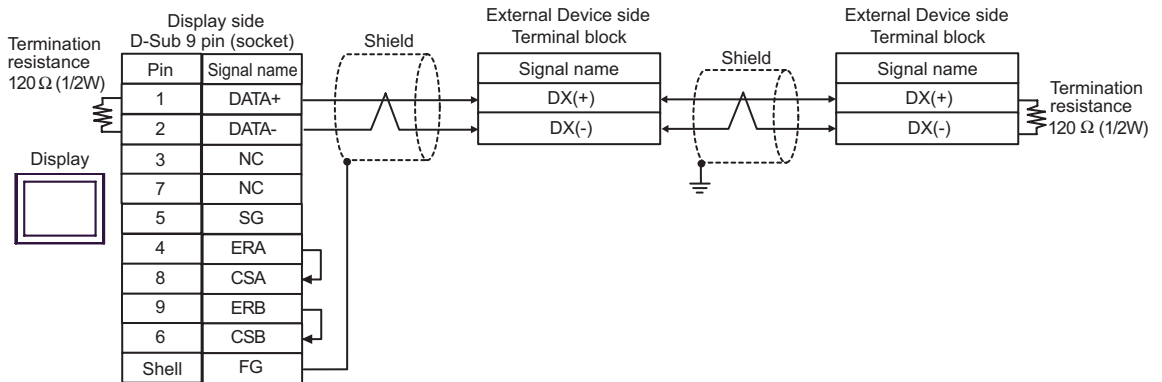

4G)

- 1:1 Connection

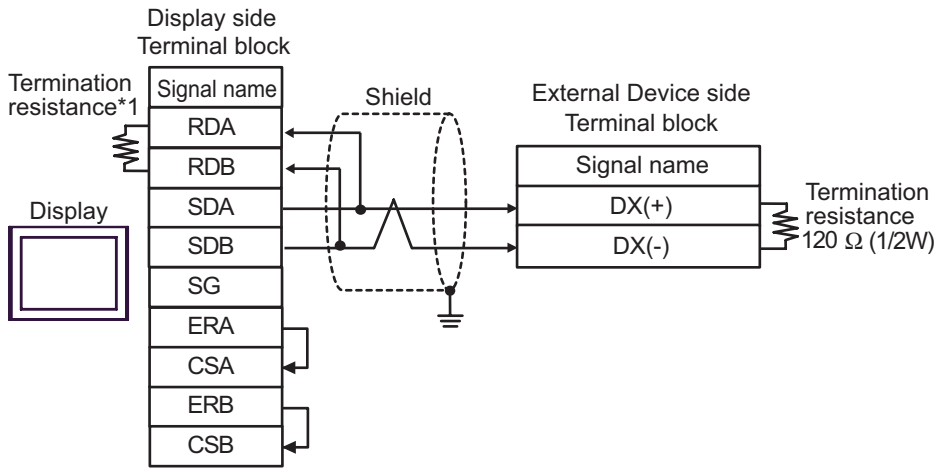

- 1:n Connection

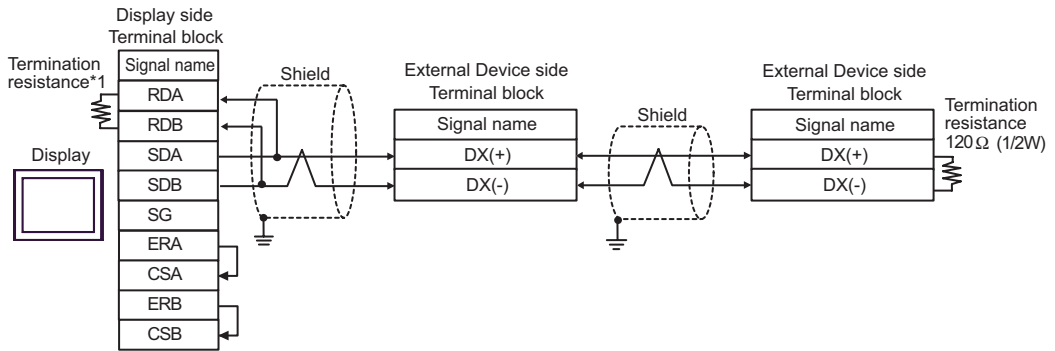

\*1 The resistance in the Display is used as the termination resistance. Set the value of the DIP Switch on the rear of the Display as shown in the table below.

DIP Switch No.	Set Value
1	OFF
2	OFF
3	ON
4	ON

4H)

- 1:1 Connection

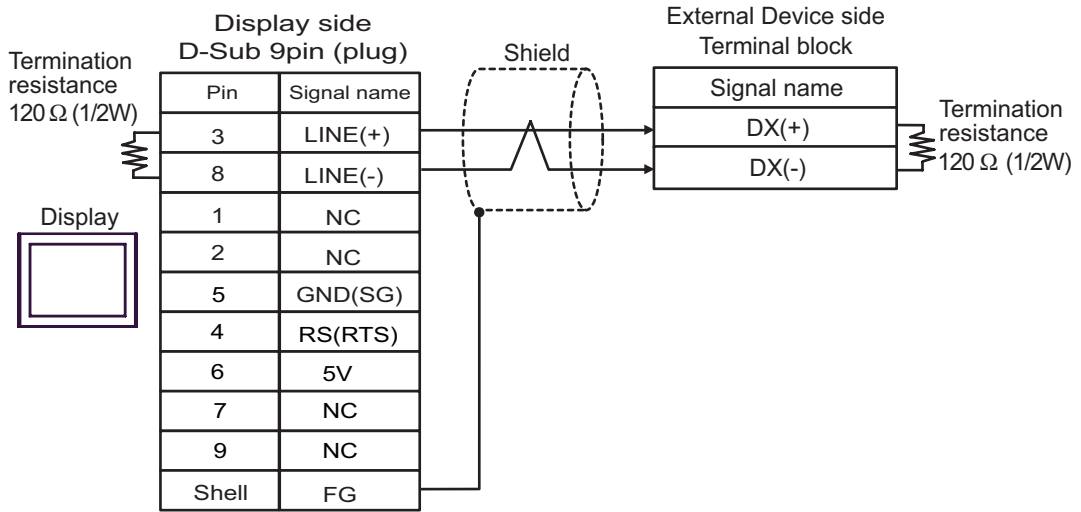

- 1:n Connection

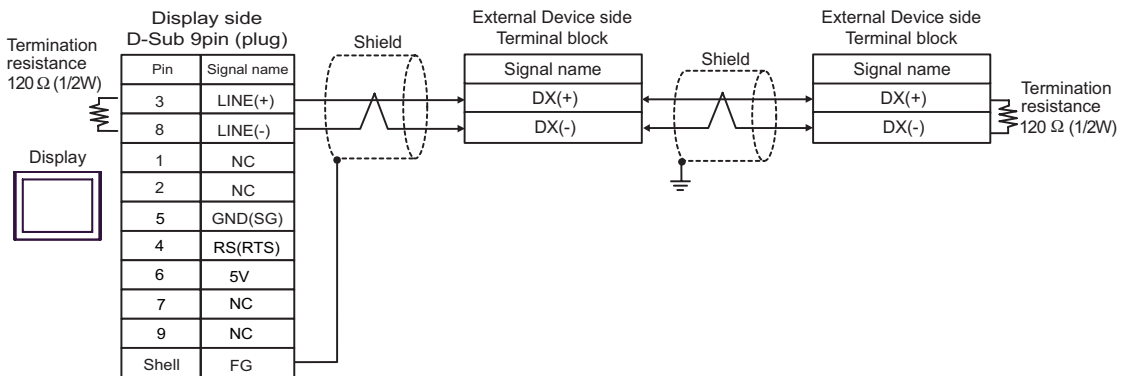

**IMPORTANT**

- The 5V output (Pin #6) on the Display is the power for the Siemens AG's PROFIBUS connector. Do not use it for other devices.

**NOTE**

- In COM on the GP-4107, the SG and FG terminals are isolated.

4l)

- 1:1 Connection

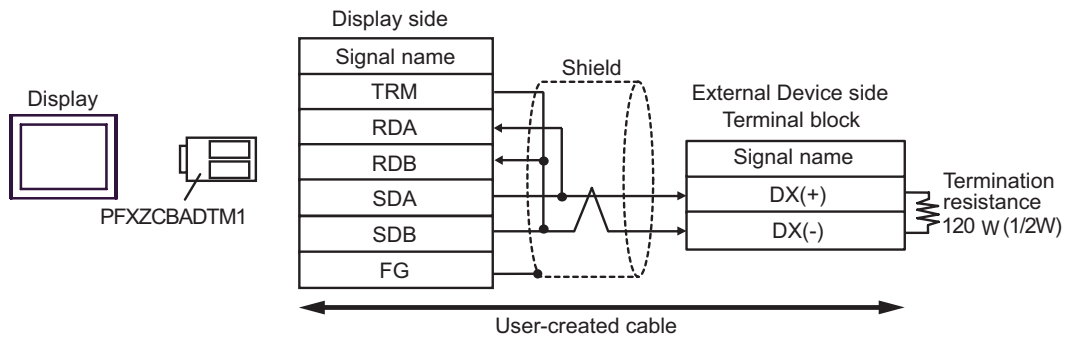

- 1:n Connection

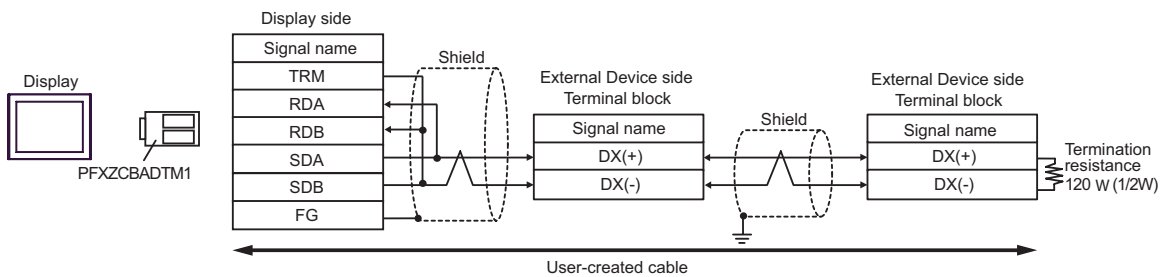

4J)

- 1:1 Connection

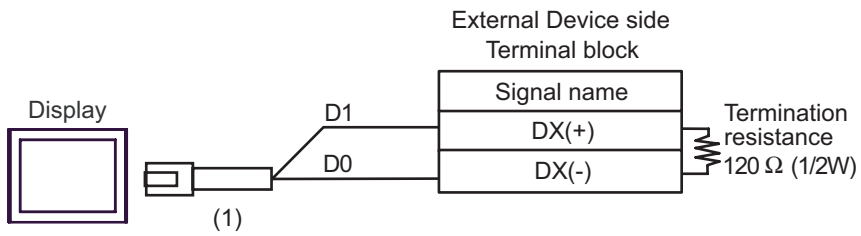

- 1:n Connection

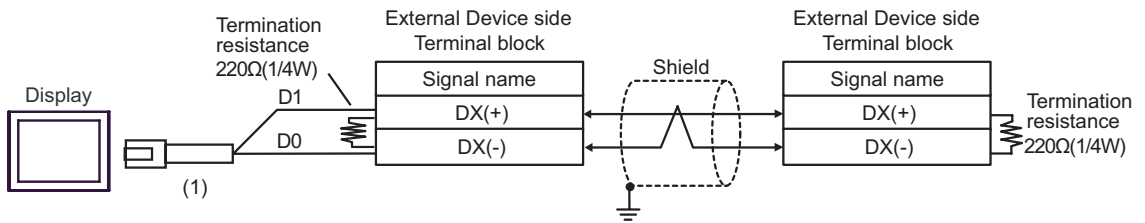

Number	Name	Notes
(1)	RJ45 RS-485 Cable (5m) by Pro-face PFXZLMCBJR81	



Cable Diagram 5

Display (Connection Port)	Cable		Remarks
GP3000* <sup>1</sup> (COM1) AGP-3302B (COM2) GP-4*0ITM (COM1) ST* <sup>2</sup> (COM2) LT3000 (COM1)	5A	The COM port conversion adapter by Pro-face CA3-ADPCOM-01 + Terminal block conversion adapter by Pro-face CA3-ADPTRM-01 + User-created cable	Cable length: 500m or less
	5B	User-created cable	
GP3000* <sup>3</sup> (COM2)	5C	Online adapter by Pro-face CA4-ADPONL-01 + Terminal block conversion adapter by Pro-face CA3-ADPTRM-01 + User-created cable	
	5D	Online adapter by Pro-face CA4-ADPONL-01 + User-created cable	
IPC* <sup>4</sup>	5E	COM port conversion adapter by Pro-face CA3-ADPCOM-01 + Terminal block conversion adapter by Pro-face CA3-ADPTRM-01 + User-created cable	
	5F	User-created cable	
GP-4106 (COM1)	5G	User-created cable	
GP-4107 (COM1) GP-4*03T* <sup>5</sup> (COM2) GP-4203T (COM1)	5H	User-created cable	
GP4000* <sup>6</sup> (COM2) GP-420IT (COM1)	5I	RS-422 Terminal Block Conversion Adapter by Pro-face PFXZCBADTM1* <sup>7</sup> + User-created cable	
	5B	User-created cable	
LT-4*0ITM (COM1)	5J	RJ45 RS-485 Cable (5m) by Pro-face PFXZLMCBJR81	

\*1 All GP3000 models except AGP-3302B

\*2 All ST models except AST-3211A and AST-3302B

\*3 All GP3000 models except the GP-3200 Series and AGP-3302B

\*4 Only a COM port which can communicate by RS-422/485 (2-wire) can be used.

 ■ IPC COM Port (page 5)

- \*5 Except GP-4203T
- \*6 All GP4000 models except GP-4100 Series, GP-4\*01TM, GP-4201T and GP-4\*03T
- \*7 When using a Terminal Block Conversion Adapter (CA3-ADPTRM-01) instead of the RS-422 Terminal Block Conversion Adapter, refer to Cable Diagram 5A.

- The following cables are recommended as the connecting cable for use with RJ-45 connectors.

Parts name	Model	Remarks
Extension cable by Fuji Electric Systems Co., Ltd.	CB-5S, CB-3S, CB-1S	3 cables available in length of 5m, 3m, and 1m.

When using an off-the-shelf LAN cable, use a 10BASE-T/100BASE-TX straight type cable (less than 20m) compliant to US ANSI TIA/EIA-568A Category 5.

The recommended LAN cables are KB-10T5-01K (1m) and KB-STP-01K (1m) (Shielded LAN cable compliant with EMC Directive) by SANWA Supply Co., Ltd.

- The recommended connection cable between the terminal block of the Display side and the RJ-45 connector is the Furukawa Electric's AWM2789 long-distance cable.
- Set the termination resistance switch on the External Device as follows:

Series	Switch	Setting
FRENIC-Multi OPC-E1-RS card	SW9	ON

- The following are RJ-45 connector pin numbers for the FRENIC-Multi series.

Pin No.	FRENIC-Multi
1	VCC (+5V)
2	GND
3	NC
4	DX (-)
5	DX (+)
6	NC
7	GND
8	VCC (+5V)

**IMPORTANT**

- Do not use FRENIC-Multi Series pin numbers 1, 2, 7 and 8 for communications. Refer to your External Device manual for details.

5A)

- 1:1 Connection

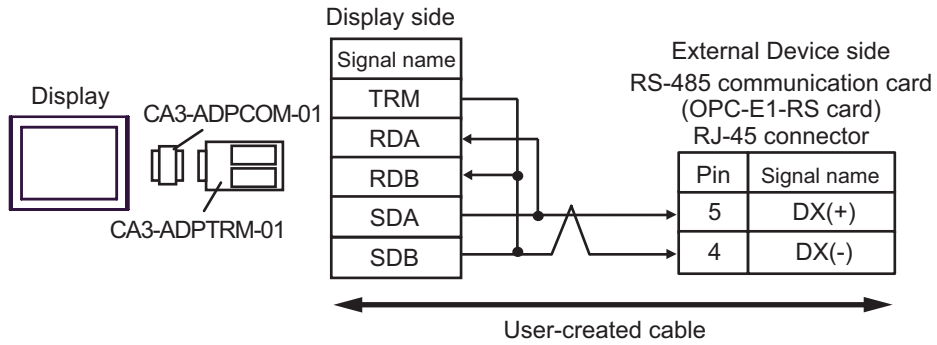

- 1:n Connection

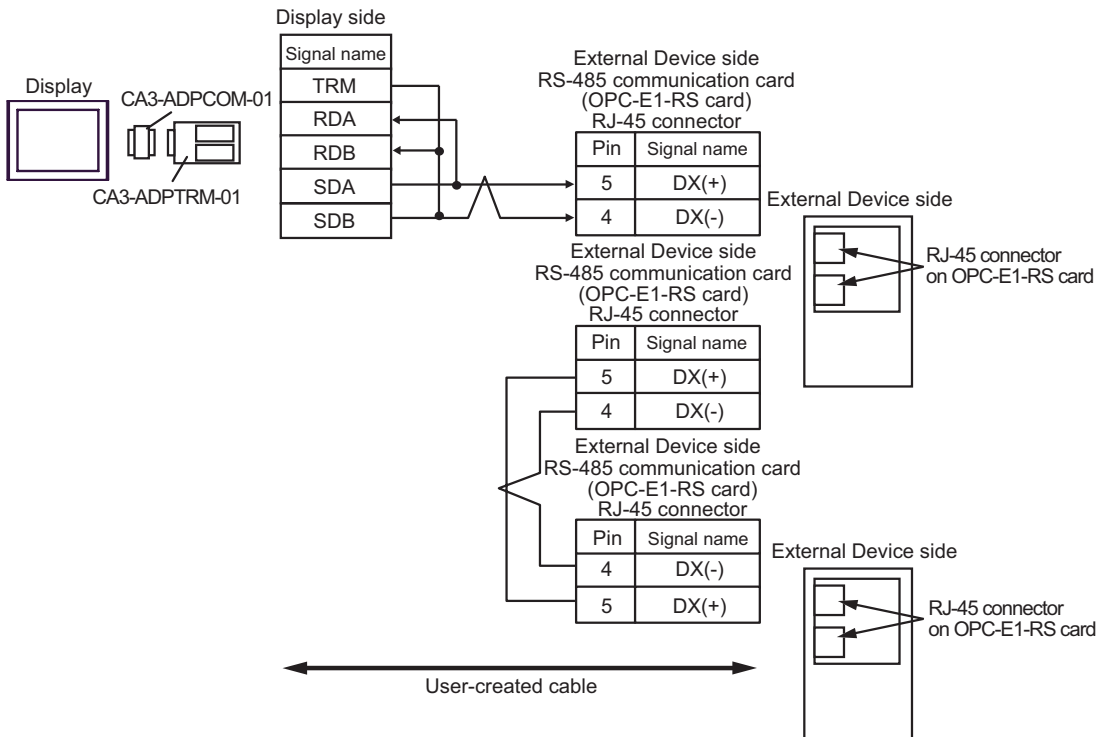

**NOTE**

- For 1:n connection, set the termination resistance switch on the External Device located at the end to ON.

5B)

- 1:1 Connection

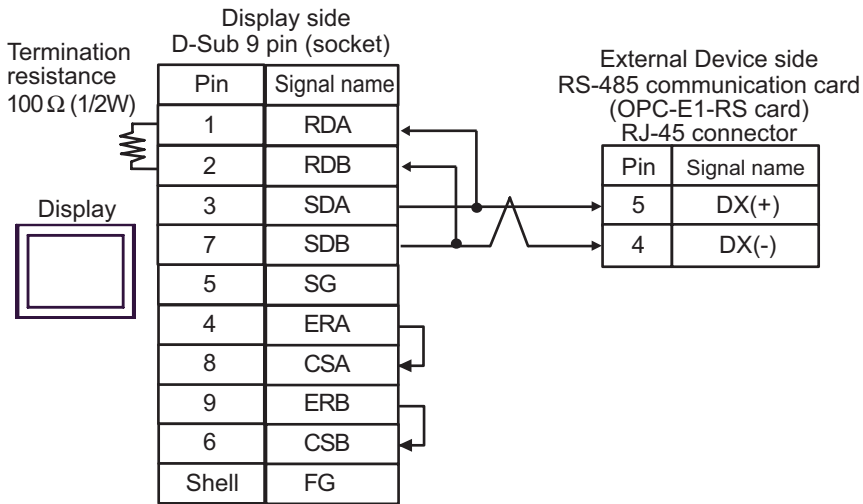

- 1:n Connection

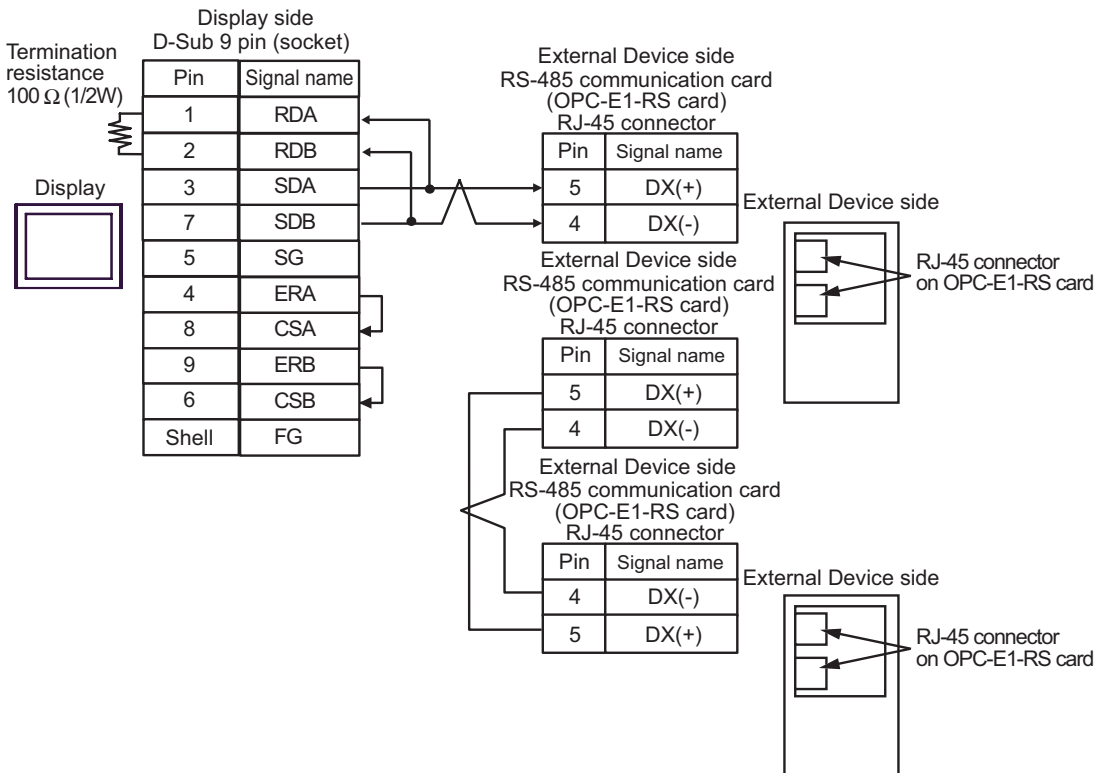

**NOTE**

- For 1:n connection, set the termination resistance switch on the External Device located at the end to ON.

5C)

- 1:1 Connection

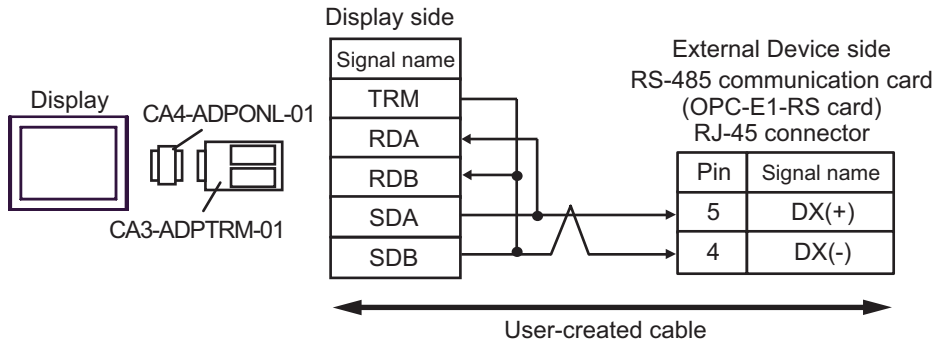

- 1:n Connection

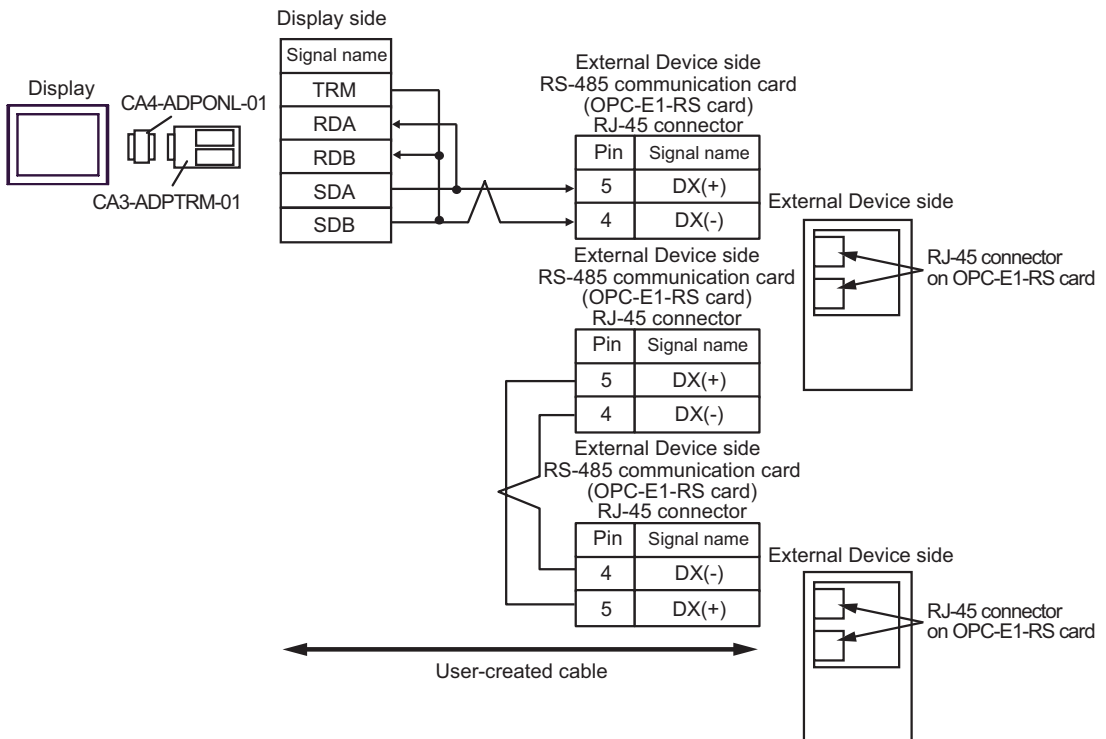

**NOTE**

- For 1:n connection, set the termination resistance switch on the External Device located at the end to ON.

5D)

- 1:1 Connection

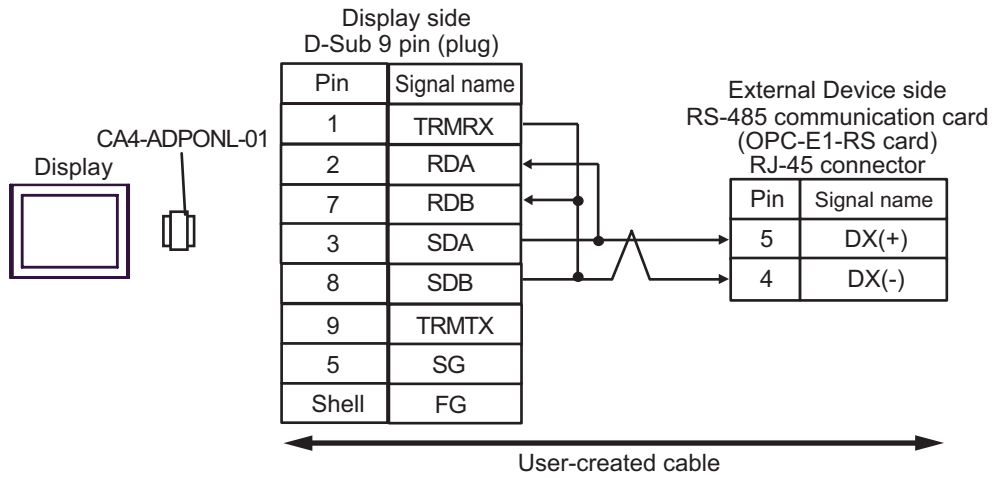

- 1:n Connection

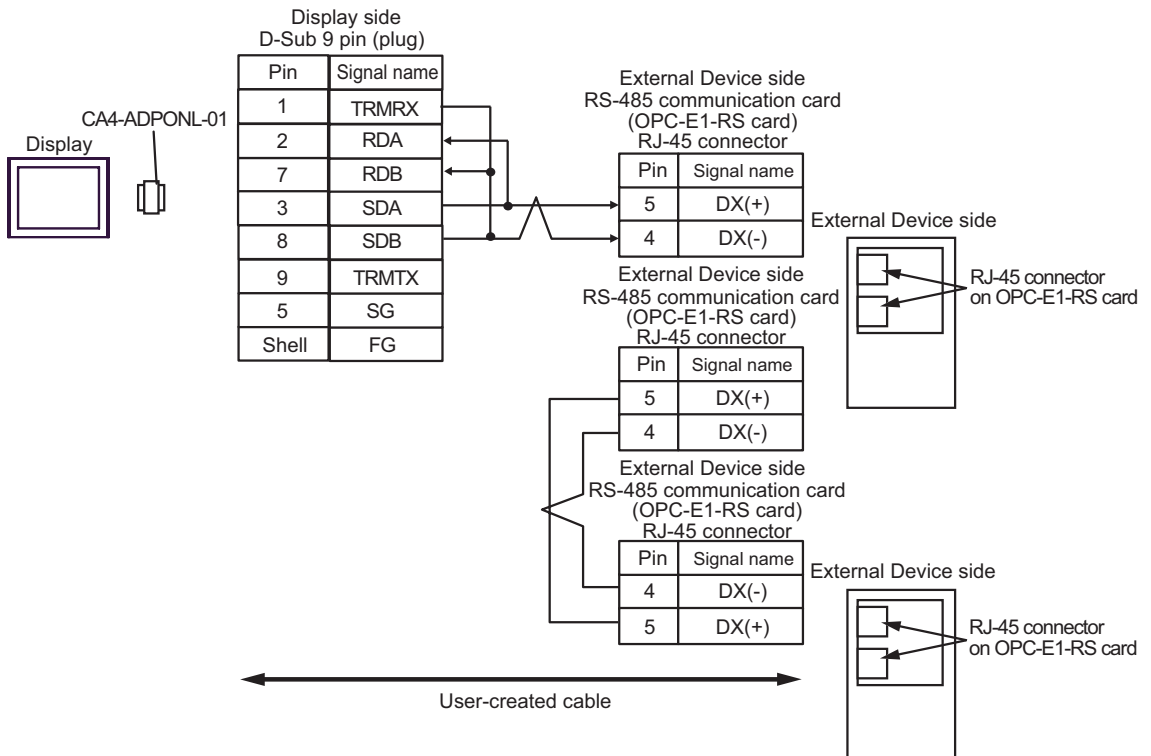

**NOTE**

- For 1:n connection, set the termination resistance switch on the External Device located at the end to ON.

5E)

- 1:1 Connection

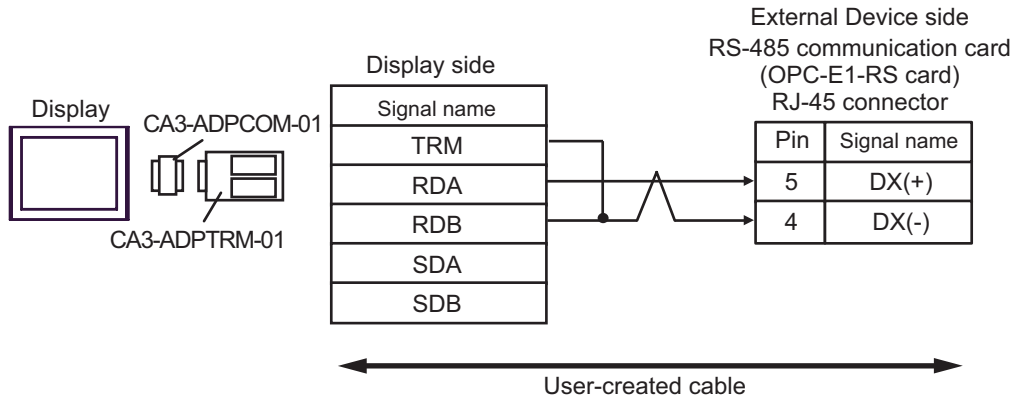

- 1:n Connection

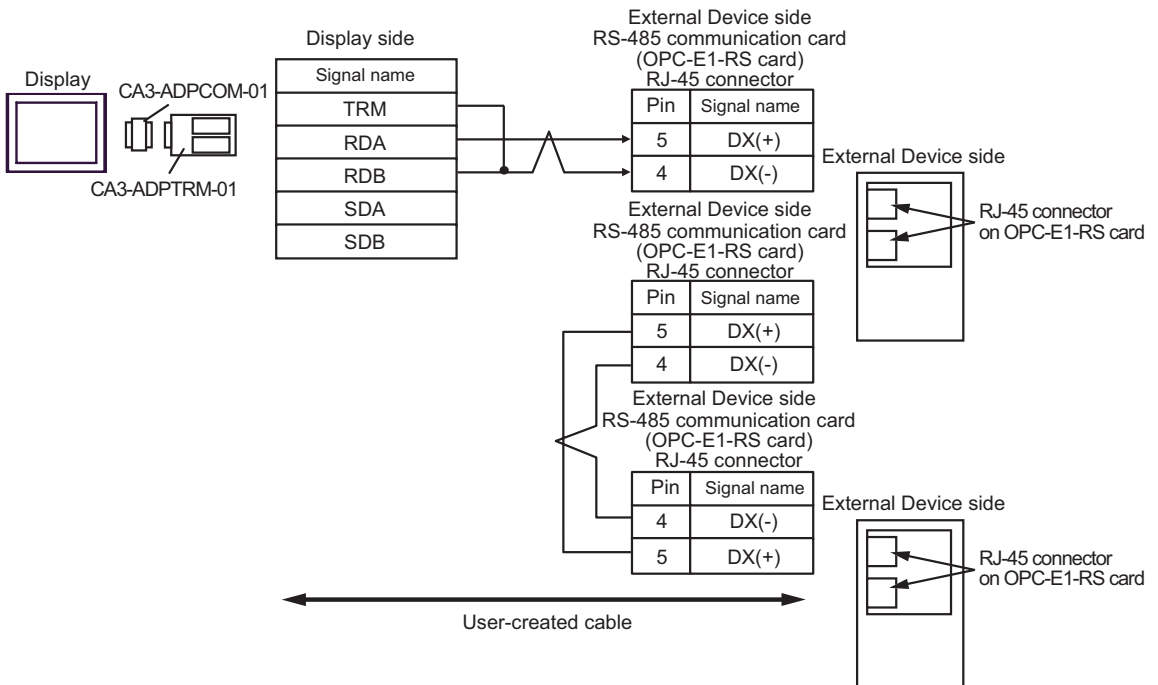

**NOTE**

- For 1:n connection, set the termination resistance switch on the External Device located at the end to ON.

5F)

- 1:1 Connection

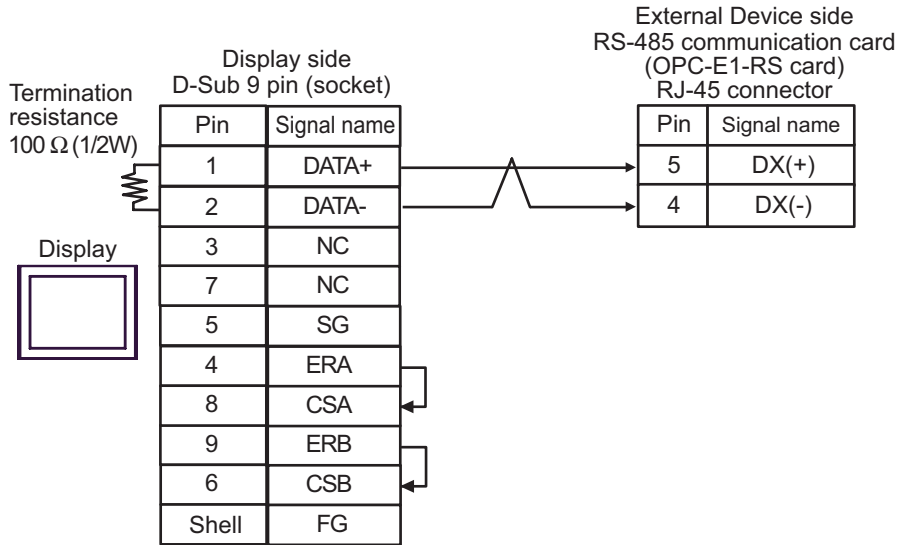

- 1:n Connection

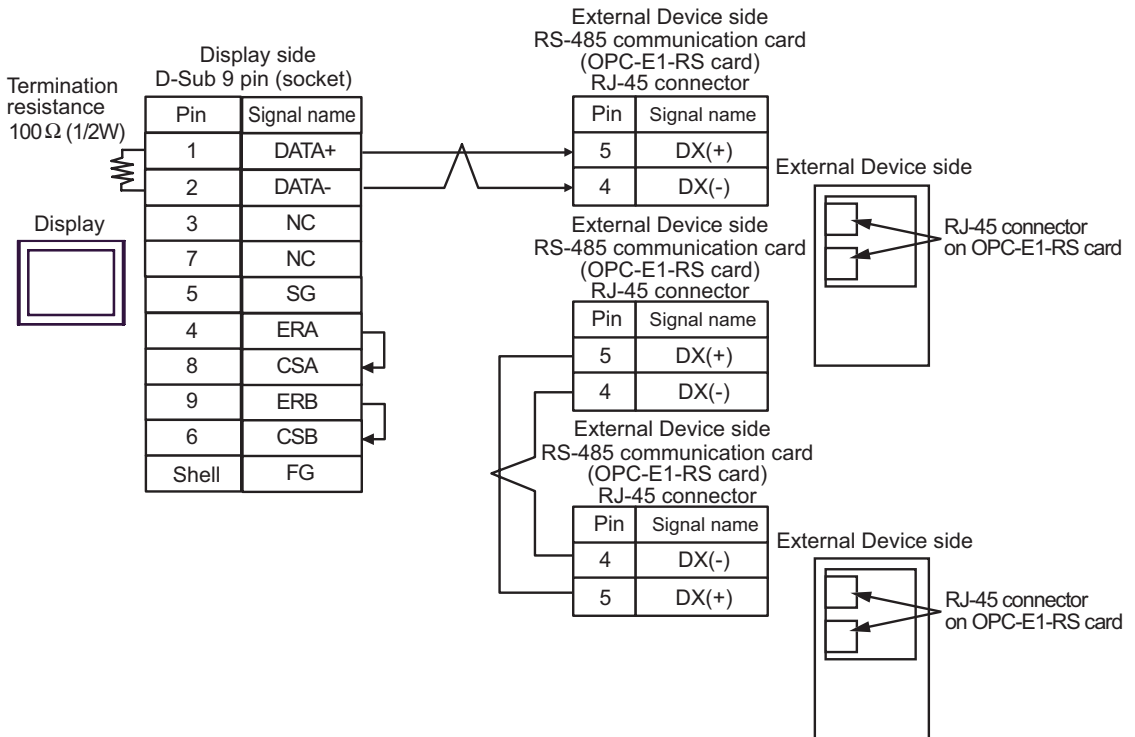

**NOTE** • For 1:n connection, set the termination resistance switch on the External Device located at the end to ON.



5G)

- 1:1 Connection

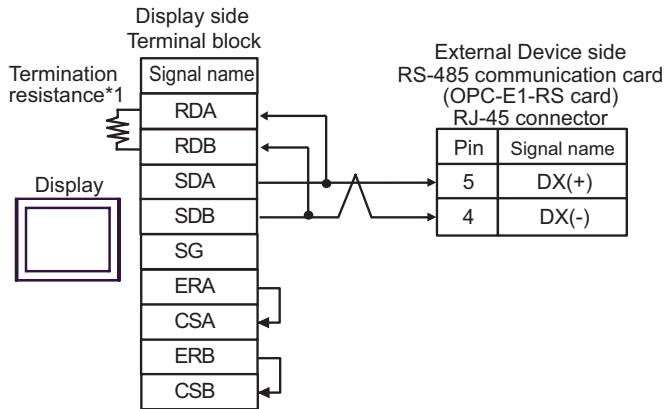

- 1:n Connection

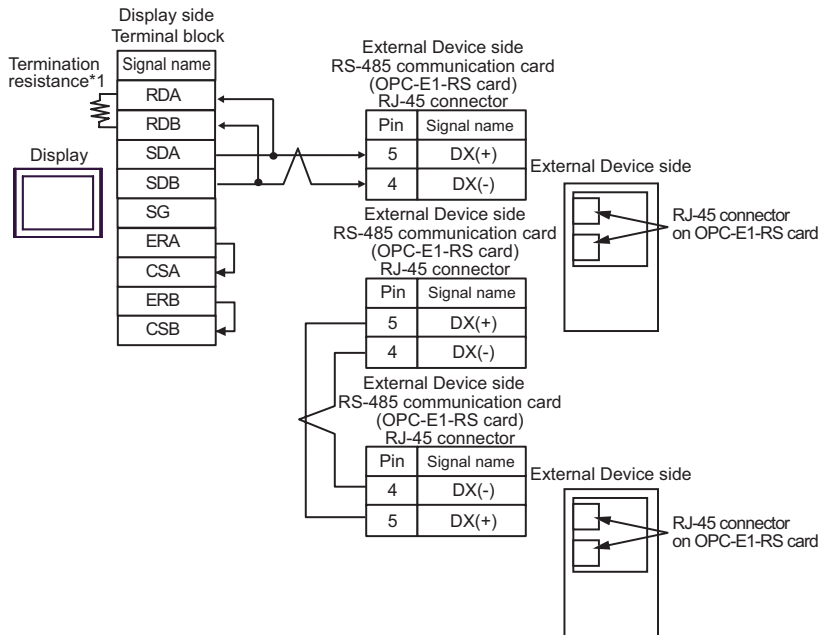

**NOTE**

- For 1:n connection, set the termination resistance switch on the External Device located at the end to ON.

\*1 The resistance in the Display is used as the termination resistance. Set the value of the DIP Switch on the rear of the Display as shown in the table below.

DIP Switch No.	Set Value
1	OFF
2	OFF
3	ON
4	ON

5H)

- 1:1 Connection

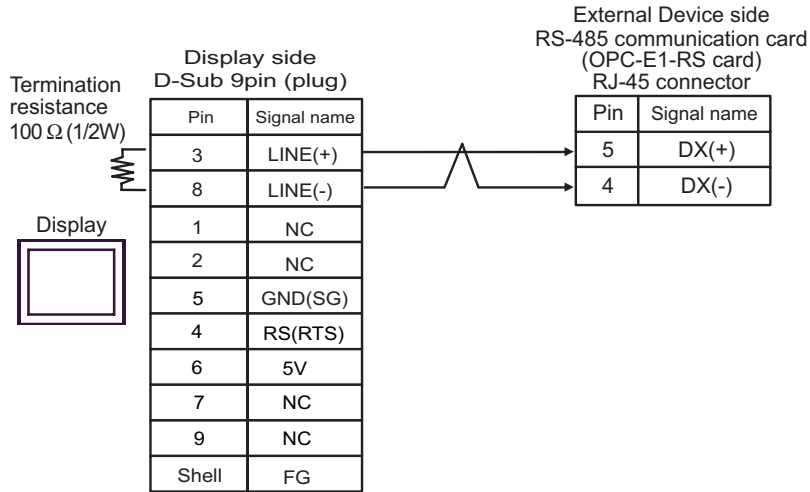

- 1:n Connection

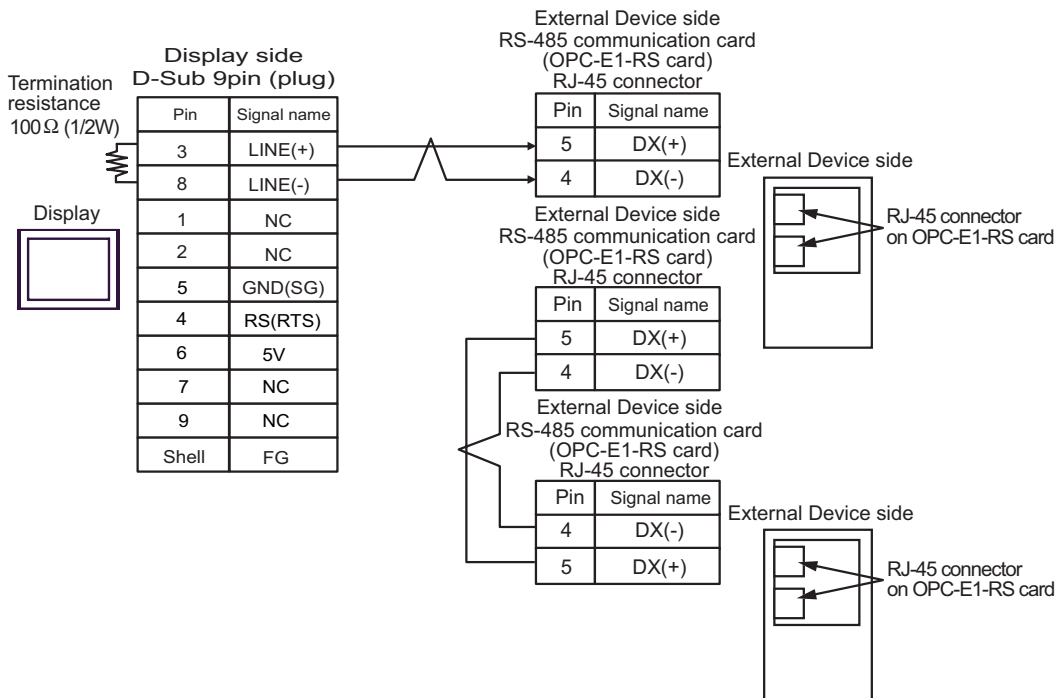

**IMPORTANT**

- The 5V output (Pin #6) on the Display is the power for the Siemens AG's PROFIBUS connector. Do not use it for other devices.

**NOTE**

- For 1:n connection, set the termination resistance switch on the External Device located at the end to ON.
- In COM on the GP-4107, the SG and FG terminals are isolated.

5l)

- 1:1 Connection

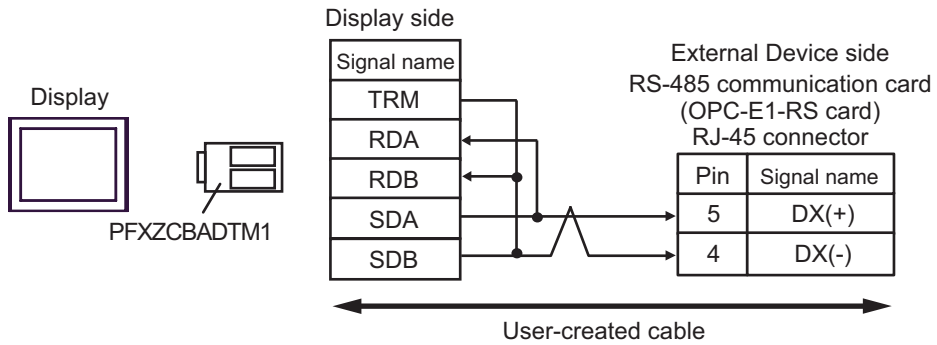

- 1:n Connection

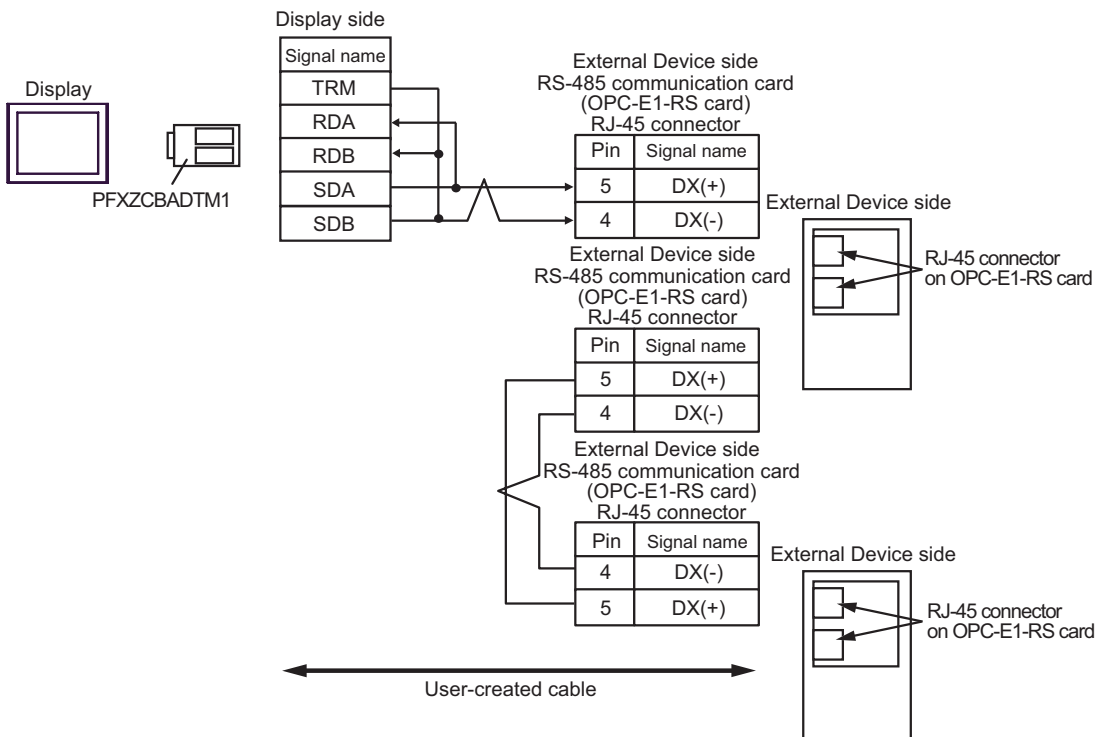

**NOTE**

- For 1:n connection, set the termination resistance switch on the External Device located at the end to ON.

5J)

- 1:1 Connection

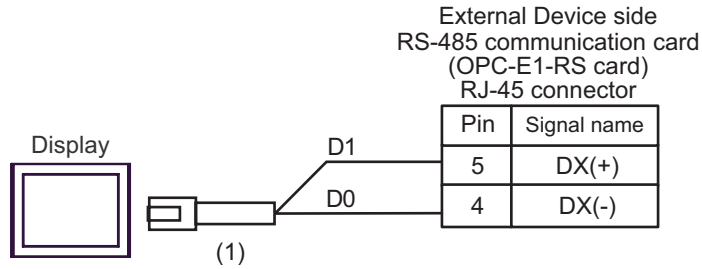

- 1:n Connection

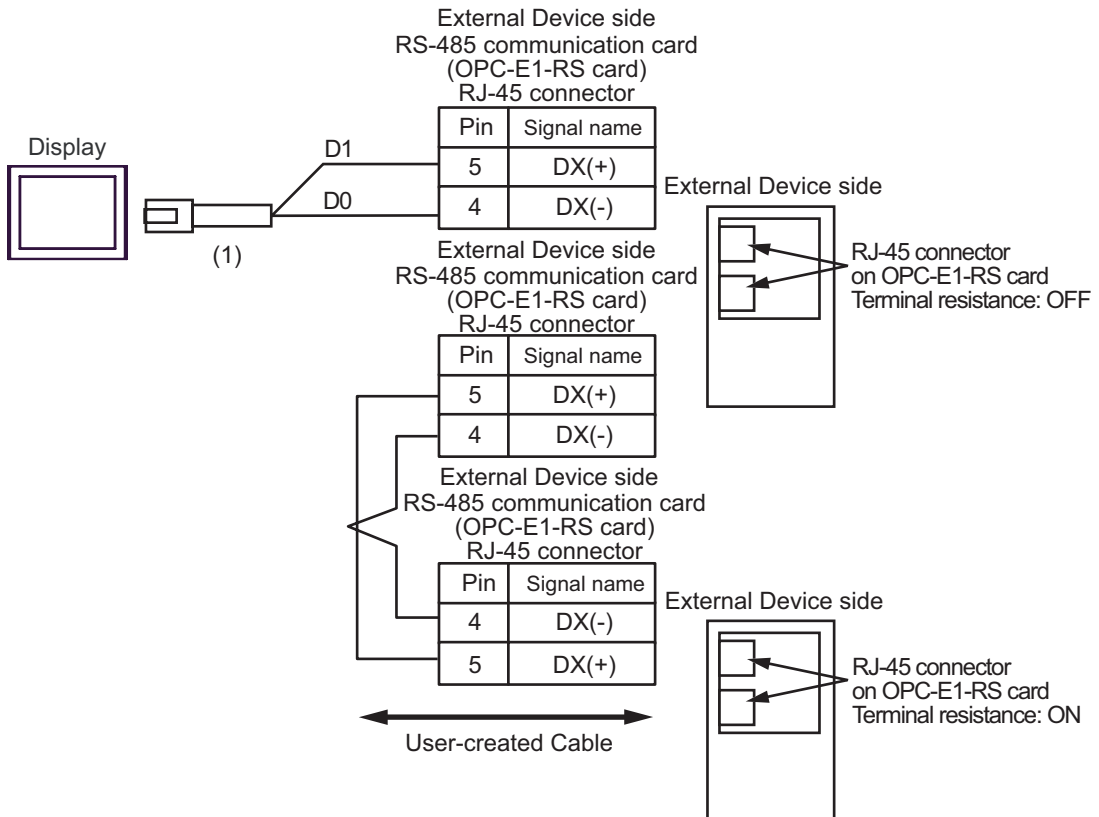

Number	Name	Notes
(1)	RJ45 RS-485 Cable (5m) by Pro-face PFXZLMCBRJ81	

**NOTE**

- For 1:n connection, set the termination resistance switch on the External Device located at the end to ON.

## 6 Supported Device Addresses

The following section shows the range of supported device addresses. Please note that the actual supported range of the devices vary depending on the External Device to be used. Please check the actual range in the manual of your External Device.

### 6.1 FRENIC5000G11S/FRENIC5000P11S Series

 : This address can be specified as system data area.

Device	Bit Address	Word address	32 bits	Remarks
Basic function	F00.00-F42.15	F00-F42		
Terminal function	E01.00-E47.15	E01-E47		
Control function	C01.00-C33.15	C01-C33		
Motor 1	P01.00-P09.15	P01-P09		
High level function	H03.00-H39.15	H03-H39		
Motor 2	A01.00-A18.15	A01-A18		
Option	o01.00-o29.15	o01-o29		
Command data	S01.00-S12.15	S01-S12		
Monitor data	M01.00-M53.31	M01-M53		*1 *2
Alarm reset	-	m0		*3 *4

\*1 Write disabled

\*2 32-bit device

\*3 The virtual device, m0, is a specialized device to reset the alarm history generated by External Devices. The alarm reset is executed by writing random data to the m0.

\*4 Read disabled

**NOTE**

- You can only set the Read Area Size for the system area available to use in the External Device. Please refer to the GP Pro-EX Reference Manual for Read Area Size.

Cf. GP-Pro EX Reference Manual "LS Area (Direct Access Method Area)"

- Refer to the precautions on manual notation for icons in the table.

 "Manual Symbols and Terminology"

6.2 FVR-E11S Series

 : This address can be specified as system data area.

Device	Bit Address	Word address	32 bits	Remarks
Basic function	F00.00-F42.15	F00-F42	<b>L/H</b>	
Terminal function	E01.00-E42.15	E01-E42		
Control function	C01.00-C33.15	C01-C33		
Motor 1	P01.00-P10.15	P01-P10		
High level function	H01.00-H46.15	H01-H46		
Motor 2	A01.00-A19.15	A01-A19		
Optional function	o00.00-o00.15	o00		
Command data	S01.00-S11.15	S01-S11		
Monitor data	M01.00-M48.31	M01-M48		*1 *2
Alarm reset	-	m0		*3 *4

\*1 Write disabled

\*2 32-bit device

\*3 The virtual device, m0, is a specialized device to reset the alarm history generated by External Devices. The alarm reset is executed by writing random data to the m0.

\*4 Read disabled

**NOTE**

- You can only set the Read Area Size for the system area available to use in the External Device. Please refer to the GP Pro-EX Reference Manual for Read Area Size.  
Cf. GP-Pro EX Reference Manual "LS Area (Direct Access Method Area)"
- Refer to the precautions on manual notation for icons in the table.  
 "Manual Symbols and Terminology"

6.3 FVR-C11S Series

 : This address can be specified as system data area.

Device	Bit Address	Word address	32 bits	Remarks
Basic function	F00.00-F36.15	F00-F36		
Terminal function	E01.00-E03.15	E01-E03		
Control function	C01.00-C07.15	C01-C07		
Motor 1	P00.00-P00.15	P00		
High level function	H01.00-H25.15	H01-H25		
Option	o00.00-o11.15	o00-o11		
Command data	S05.00-S06.15	S05-S06		
Monitor data	M01.00-M48.31	M01-M48		*1 *2
Alarm reset	-	m0	*3 *4	

- \*1 Write disabled
- \*2 32-bit device
- \*3 The virtual device, m0, is a specialized device to reset the alarm history generated by External Devices. The alarm reset is executed by writing random data to the m0.
- \*4 Read disabled

**NOTE**

- You can only set the Read Area Size for the system area available to use in the External Device. Please refer to the GP Pro-EX Reference Manual for Read Area Size.  
Cf. GP-Pro EX Reference Manual "LS Area (Direct Access Method Area)"
- Refer to the precautions on manual notation for icons in the table.  
 "Manual Symbols and Terminology"

6.4 FRENIC-MEGA Series

 : This address can be specified as system data area.

Device	Bit Address	Word address	32 bits	Remarks
Fundamental function	F00.00-F80.15	F00-F80		
Extension terminal function	E01.00-E99.15	E01-E99		
Control function of frequency	C01.00-C53.15	C01-C53		
Motor 1 parameter	P01.00-P99.15	P01-P99		
High performance function	H03.00-H98.15	H03-H98		
Motor 2 parameter	A01.00-A57.15	A01-A57		
Optional function	o19.00-o59.15	o19-o59		
Command data	S01.00-S19.15	S01-S19		
Monitor data 1	M01.00-M89.31	M01-M89		*1 *2
Motor 3 parameter	b01.00-b57.15	b01-b57		
Motor 4 parameter	r01.00-r57.15	r01-r57		
Application function 1	J01.00-J99.15	J01-J99		
Application function 2	d01.00-d99.15	d01-d99		
Link function	y01.00-y99.15	y01-y99		
Monitor data 2	W01.00-W99.15	W01-W99		*1
Alarm data 1	X00.00-X77.15	X00-X77		*1
Alarm data 2	Z00.00-Z95.15	Z00-Z95	*1	
Alarm reset	-	m0	*3 *4	

\*1 Write disabled

\*2 32-bit device

\*3 The virtual device, m0, is a specialized device to reset the alarm history generated by External Devices. The alarm reset is executed by writing random data to the m0.

\*4 Read disabled

**NOTE**

- You can only set the Read Area Size for the system area available to use in the External Device. Please refer to the GP Pro-EX Reference Manual for Read Area Size.

Cf. GP-Pro EX Reference Manual "LS Area (Direct Access Method Area)"

- Refer to the precautions on manual notation for icons in the table.

 "Manual Symbols and Terminology"



6.5 FRENIC-Mini Series

 : This address can be specified as system data area.

Device	Bit Address	Word address	32 bits	Remarks
Fundamental function	F00.00-F51.15	F00-F51		
Extension terminal function	E01.00-E99.15	E01-E99		
Control function of frequency	C01.00-C52.15	C01-C52		
Motor 1 parameter	P02.00-P99.15	P02-P99		
High performance function	H03.00-H98.15	H03-H98		
Command data	S01.00-S14.15	S01-S14		
Monitor data 1	M01.00-M71.31	M01-M71		*1 *2
Application function 1	J01.00-J06.15	J01-J06		
Link function	y01.00-y99.15	y01-y99		
Monitor data 2	W01.00-W89.15	W01-W89		*1
Alarm data 1	X00.00-X74.15	X00-X74		*1
Alarm data 2	Z00.00-Z64.15	Z00-Z64		*1
Alarm reset	-	m0		*3 *4

\*1 Write disabled

\*2 32-bit device

\*3 The virtual device, m0, is a specialized device to reset the alarm history generated by External Devices. The alarm reset is executed by writing random data to the m0.

\*4 Read disabled

**NOTE**

- You can only set the Read Area Size for the system area available to use in the External Device. Please refer to the GP Pro-EX Reference Manual for Read Area Size.  
Cf. GP-Pro EX Reference Manual "LS Area (Direct Access Method Area)"
- Refer to the precautions on manual notation for icons in the table.  
 "Manual Symbols and Terminology"

6.6 FRENIC-Eco Series

 : This address can be specified as system data area.

Device	Bit Address	Word address	32 bits	Remarks
Fundamental function	F00.00-F44.15	F00-F44	<b>[L/H]</b>	
Extension terminal function	E01.00-E99.15	E01-E99		
Control function of frequency	C01.00-C53.15	C01-C53		
Motor 1 parameter	P01.00-P99.15	P01-P99		
High performance function	H03.00-H98.15	H03-H98		
Optional function	o27.00-o59.15	o27-o59		
Command data	S01.00-S14.15	S01-S14		
Monitor data 1	M01.00-M73.31	M01-M73		*1 *2
Application function 1	J01.00-J22.15	J01-J22		
Link function	y01.00-y99.15	y01-y99		
Monitor data 2	W01.00-W96.15	W01-W96		*1
Alarm data 1	X00.00-X74.15	X00-X74		*1
Alarm data 2	Z00.00-Z64.15	Z00-Z64		*1
Alarm reset	-	m0		*3 *4

\*1 Write disabled

\*2 32-bit device

\*3 The virtual device, m0, is a specialized device to reset the alarm history generated by External Devices. The alarm reset is executed by writing random data to the m0.

\*4 Read disabled

**NOTE**

- You can only set the Read Area Size for the system area available to use in the External Device. Please refer to the GP Pro-EX Reference Manual for Read Area Size.  
Cf. GP-Pro EX Reference Manual "LS Area (Direct Access Method Area)"
- Refer to the precautions on manual notation for icons in the table.  
 "Manual Symbols and Terminology"

6.7 FRENIC-Multi Series

 : This address can be specified as system data area.

Device	Bit Address	Word address	32 bits	Remarks
Fundamental function	F00.00-F51.15	F00-F51		
Extension terminal function	E01.00-E99.15	E01-E99		
Control function of frequency	C01.00-C53.15	C01-C53		
Motor 1 parameter	P01.00-P99.15	P01-P99		
High performance function	H03.00-H98.15	H03-H98		
Motor 2 parameter	A01.00-A46.15	A01-A46		
Optional function	o01.00-o59.15	o01-o59		
Command data	S01.00-S14.15	S01-S14		
Monitor data 1	M01.00-M73.31	M01-M73		*1 *2
Application function 1	J01.00-J92.15	J01-J92		
Link function	y01.00-y99.15	y01-y99		
Monitor data 2	W01.00-W96.15	W01-W96		*1
Alarm data 1	X00.00-X74.15	X00-X74		*1
Alarm data 2	Z00.00-Z64.15	Z00-Z64		*1
Alarm reset	-	m0		*3 *4

\*1 Write disabled

\*2 32-bit device

\*3 The virtual device, m0, is a specialized device to reset the alarm history generated by External Devices. The alarm reset is executed by writing random data to the m0.

\*4 Read disabled

**NOTE**

- You can only set the Read Area Size for the system area available to use in the External Device. Please refer to the GP Pro-EX Reference Manual for Read Area Size.

Cf. GP-Pro EX Reference Manual "LS Area (Direct Access Method Area)"

- Refer to the precautions on manual notation for icons in the table.

 "Manual Symbols and Terminology"

## 7 Device Code and Address Code

Use device code and address code if you select "Device Type & Address" for the address type of the data display.

### 7.1 FRENIC5000G11S/FRENIC5000P11S Series

Device	Device Name	Device Code (HEX)	Address Code
Basic function	F	0080	Word address
Terminal function	E	0081	Word address
Control function	C	0082	Word address
Motor 1	P	0083	Word address
High level function	H	0084	Word address
Motor 2	A	0085	Word address
Option	o	0086	Word address
Command data	S	0087	Word address
Monitor data	M	0088	Word address
Alarm reset	m	0060	Word address

### 7.2 FVR-E11S Series

Device	Device Name	Device Code (HEX)	Address Code
Basic function	F	0080	Word address
Terminal function	E	0081	Word address
Control function	C	0082	Word address
Motor 1	P	0083	Word address
High level function	H	0084	Word address
Motor 2	A	0085	Word address
Optional function	o	0086	Word address
Command data	S	0087	Word address
Monitor data	M	0088	Word address
Alarm reset	m	0060	Word address

### 7.3 FVR-C11S Series

Device	Device Name	Device Code (HEX)	Address Code
Basic function	F	0080	Word address
Terminal function	E	0081	Word address
Control function	C	0082	Word address
Motor 1	P	0083	Word address
High level function	H	0084	Word address
Option	o	0086	Word address
Command data	S	0087	Word address
Monitor data	M	0088	Word address
Alarm reset	m	0060	Word address

### 7.4 FRENIC-MEGA Series

Device	Device Name	Device Code (HEX)	Address Code
Fundamental function	F	0080	Word address
Extension terminal function	E	0081	Word address
Control function of frequency	C	0082	Word address
Motor 1 parameter	P	0083	Word address
High performance function	H	0084	Word address
Motor 2 parameter	A	0085	Word address
Option function	o	0086	Word address
Command data	S	0087	Word address
Monitor data 1	M	0088	Word address
Motor 3 parameter	b	0089	Word address
Motor 4 parameter	r	008A	Word address
Application function 1	J	008B	Word address
Application function 2	d	008C	Word address
Link function	y	008D	Word address
Monitor data 2	W	008E	Word address
Alarm data 1	X	008F	Word address
Alarm data 2	Z	0090	Word address
Alarm reset	m	0060	Word address

### 7.5 FRENIC-Mini Series

Device	Device Name	Device Code (HEX)	Address Code
Fundamental function	F	0080	Word address
Extension terminal function	E	0081	Word address
Control function of frequency	C	0082	Word address
Motor 1 parameter	P	0083	Word address
High performance function	H	0084	Word address
Command data	S	0087	Word address
Monitor data 1	M	0088	Word address
Application function 1	J	008B	Word address
Link function	y	008D	Word address
Monitor data 2	W	008E	Word address
Alarm data 1	X	008F	Word address
Alarm data 2	Z	0090	Word address
Alarm reset	m	0060	Word address

### 7.6 FRENIC-Eco Series

Device	Device Name	Device Code (HEX)	Address Code
Fundamental function	F	0080	Word address
Extension terminal function	E	0081	Word address
Control function of frequency	C	0082	Word address
Motor 1 parameter	P	0083	Word address
High performance function	H	0084	Word address
Option function	o	0086	Word address
Command data	S	0087	Word address
Monitor data 1	M	0088	Word address
Application function 1	J	008B	Word address
Link function	y	008D	Word address
Monitor data 2	W	008E	Word address
Alarm data 1	X	008F	Word address
Alarm data 2	Z	0090	Word address
Alarm reset	m	0060	Word address

## 7.7 FRENIC-Multi Series

Device	Device Name	Device Code (HEX)	Address Code
Fundamental function	F	0080	Word address
Extension terminal function	E	0081	Word address
Control function of frequency	C	0082	Word address
Motor 1 parameter	P	0083	Word address
High performance function	H	0084	Word address
Motor 2 parameter	A	0085	Word address
Option function	o	0086	Word address
Command data	S	0087	Word address
Monitor data 1	M	0088	Word address
Application function 1	J	008B	Word address
Link function	y	008D	Word address
Monitor data 2	W	008E	Word address
Alarm data 1	X	008F	Word address
Alarm data 2	Z	0090	Word address
Alarm reset	m	0060	Word address

## 8 Error Messages

Error messages are displayed on the Display screen as follows: "No. : Device Name: Error Message (Error Occurrence Area)". Each description is shown below.

Item	Description
No.	Error number.
Device Name	Name of the External Device where an error has occurred. Device/PLC name is the title of the External Device set with GP-Pro EX. (Initial value [PLC1])
Error Message	Displays messages related to an error that has occurred.
Error Occurrence Area	<p>Displays the IP address or device address of the External Device where an error has occurred, or error codes received from the External Device.</p> <p><b>NOTE</b></p> <ul style="list-style-type: none"> <li>• IP addresses are displayed as "IP address (Decimal): MAC address (Hex)".</li> <li>• Device addresses are displayed as "Address: Device address".</li> <li>• Received error codes are displayed as "Decimal [Hex]".</li> </ul>

Example of an Error Messages

"RHAA035: PLC1: Error has been responded for device write command (Error Code: 2 [02H])"

**NOTE**

- Refer to your External Device manual for details on received error codes.
- Refer to "Display-related errors" in "Maintenance/Troubleshooting Guide" for details on the error messages common to the driver.

◆ Error Codes Unique to External Device

Error Code	Description
4AH	<p>Format error</p> <ul style="list-style-type: none"> <li>• The characters of the transmission request are incorrect.</li> <li>• The last character of the message is not in the specified position.</li> </ul>
4BH	<p>Command error</p> <ul style="list-style-type: none"> <li>• A command that does not exist was transmitted.</li> </ul>
4CH	<p>Link priority error*<sup>1</sup></p> <ul style="list-style-type: none"> <li>• A frequency command, PID command, or change command of the run command (writing request to S01, S05, S06, and S13) are sent through the communication route other than that specified with H30.</li> </ul>
4DH	<p>Unauthorized write error</p> <ul style="list-style-type: none"> <li>• An attempt was made to write another function data during writing from link option.</li> </ul>
4EH	<p>Function code error</p> <ul style="list-style-type: none"> <li>• A function code that does not exist was requested.</li> </ul>
4FH	<p>Write disabled error</p> <ul style="list-style-type: none"> <li>• An attempt was made during operation to write the function code for write disabled or for write disabled during operation.</li> </ul>

continued to next page



Error Code	Description
50H	Data error <ul style="list-style-type: none"><li data-bbox="385 208 830 237">• The write data is beyond the writable range.</li></ul>
51H	Error during writing <ul style="list-style-type: none"><li data-bbox="385 285 1140 314">• An attempt was made to write another function data during function writing.</li></ul>

\*1 This error does not occur in FRENIC-Mini Series.

