

Easy! Smooth!  
GLC2000 Series  
Replacement Booklet



## Preface

This manual introduces the procedures to replace the unit in the GLC2000 series (GLC2600T, GLC2500T, GLC2400T, 2300T/L) with the GP3000 series C class, FLEX NETWORK type (GP-3600T-FN1M, GP-3500T-FN1M, GP-3400T-FN1M, GP-3300T/L-FN1M). The recommended replacement models are as follows.

GLC-2600T	<b>GP-3600T-FN1M</b>
GLC-2500T	<b>GP-3500T-FN1M</b>
GLC-2400T	<b>GP-3400T-FN1M</b>
GLC-2300T	<b>GP-3300T-FN1M</b>
GLC-2300L	<b>GP-3300L-FN1M</b>

First Edition:October 2008



**Table of Contents**

<b>PREFACE</b>	<b>2</b>
<b>TABLE OF CONTENTS</b>	<b>3</b>
<b>CHAPTER 1. SPECIFICATION COMPARISON</b>	<b>5</b>
1.1 SPECIFICATIONS OF GLC-2600T AND GP-3600T-FN1M	5
1.2 SPECIFICATIONS OF GLC-2500T AND GP-3500T-FN1M	6
1.3 SPECIFICATIONS OF GLC-2400T AND GP-3400T-FN1M	7
1.4 SPECIFICATIONS OF GLC-2300T/L AND GP-3300T/L-FN1M	8
<b>CHAPTER 2. COMPATIBILITY OF HARDWARE</b>	<b>9</b>
2.1 LOCATIONS OF CONNECTORS	9
2.2 ABOUT PANEL CUT DIMENSIONS (3500T)	11
2.3 TOUCH PANEL SPECIFICATIONS	11
2.4 ABOUT TRANSFER CABLE	11
2.5 ABOUT INTERFACES	11
2.5.1 SERIAL INTERFACE	11
2.5.2 AUX OUTPUT	11
2.5.3 FLEX NETWORK INTERFACE	12
2.6 PERIPHERAL UNITS AND OPTION UNITS	12
2.6.1 BARCODE READER CONNECTION	12
2.6.2 PRINTER CONNECTION	12
2.6.3 EXPANSION UNIT	12
2.6.4 AMPLIFIER CONNECTION	12
2.6.5 FRONT MAINTENANCE UNIT	13
2.7 ABOUT BODY MATERIAL/COLOR	13
2.8 ABOUT POWER CONNECTOR	13
2.9 ABOUT POWER CONSUMPTION	13



<b><u>CHAPTER 3. REPLACEMENT PROCEDURE</u></b>	<b>14</b>
3.1 WORK FLOW	14
3.2 PREPARATION	16
3.3 RECEIVE SCREEN DATA FROM THE GLC2000 SERIES	17
3.4 CONVERT SCREEN DATA WITH THE PROJECT CONVERTER	20
3.6 TRANSFER SCREEN DATA TO THE GP3000 SERIES	27
3.6 DIFFERENCES AFTER CONVERSION	31
3.6.1 DIFFERENCES OF SCREEN DATA	31
3.6.2 DIFFERENCES OF SCREEN DATA	31
<b><u>CHAPTER 4. COMMUNICATION BETWEEN GP3000 SERIES AND DEVICE/PLC</u></b>	<b>33</b>
4.1 DRIVER LIST	33
4.2 SHAPES OF COM PORTS	37
4.3 MULTILINK CONNECTION	41

**Chapter 1. Specification Comparison**



**1.1 Specifications of GLC-2600T and GP-3600T-FN1M**

		GLC-2600T	GP-3600T-FN1M
			
<b>Display Type</b>		TFT Color LCD	
<b>Display Colors</b>		256 colors	<b>UP!</b> 65536 colors
<b>Display Resolution</b>		SVGA (800 × 600 pixels)	
<b>Panel Cut Dimensions (mm)</b>		301.5 (W) × 227.5 (H)	
<b>External Dimensions (mm)</b>		317 (W) × 243 (H) × 58 (D)	313 (W) × 239 (H) × 56 (D)
<b>Touch Panel Type</b>		Matrix	Resistive Film (Analog) <b>NEW!</b> → See 2.3
<b>Serial Interface</b>	<b>COM1</b>	D-Sub 25 pin (female) RS-232C/422	<b>NEW!</b> D-Sub 9 pin (male) RS-232C/485(422) Compatible
	<b>COM2</b>	D-Sub 9 pin (male) RS-232C	<b>NEW!</b> D-Sub 9 pin (female) RS-485 (422) Compatible
<b>Memory</b>	<b>Application</b>	4MB	<b>UP!</b> 8MB
	<b>SRAM</b>	256KB	<b>UP!</b> 320KB
<b>Control Memory</b>	<b>Program</b>	128KB	<b>UP!</b> 132KB
	<b>SRAM</b>	64KB	
<b>Ethernet Interface</b>		10BASE-T	10BASE-T/ <b>UP!</b> 100BASE-TX
<b>CF Card Interface</b>		✓	
<b>Printer Interface</b>		Compliant with Centronics (parallel)	<b>NEW!</b> USB
<b>Flex Network Interface</b>		✓ → See 2.5.8	
<b>USB Host Interface</b>		-	<b>NEW!</b> ✓



**1.2 Specifications of GLC-2500T and GP-3500T-FN1M**

		GLC-2500T	GP-3500T-FN1M
			
<b>Display Type</b>		TFT Color LCD	
<b>Display Colors</b>		256 colors	<b>UP!</b> 65536 colors
<b>Display Resolution</b>		VGA (640 × 480 pixels)	
<b>Panel Cut Dimensions (mm)</b>		301.5 (W) × 227.5 (H)	259 (W) × 201 (H) <b>NEW!</b> → See 2.2
<b>External Dimensions (mm)</b>		317 (W) × 243 (H) × 58 (D)	270.5(W) × 212.5 (H) × 57 (D) <b>NEW!</b> → See 2.2
<b>Touch Panel Type</b>		Matrix	Resistive Film (Analog) <b>NEW!</b> → See 2.3
<b>Serial Interface</b>	<b>COM1</b>	D-Sub 25 pin (female) RS-232C/422	<b>NEW!</b> D-Sub 9 pin (male) RS-232C/485(422) Compatible
	<b>COM2</b>	D-Sub 9 pin (male) RS-232C	<b>NEW!</b> D-Sub 9 pin (female) RS-485 (422) Compatible
<b>Memory</b>	<b>Application</b>	4MB	<b>UP!</b> 8MB
	<b>SRAM</b>	256KB	<b>UP!</b> 320KB
<b>Control Memory</b>	<b>Program</b>	128KB	<b>UP!</b> 132KB
	<b>SRAM</b>	64KB	
<b>Ethernet Interface</b>		10BASE-T	10BASE-T/ <b>UP!</b> 100BASE-TX
<b>CF Card Interface</b>		✓	
<b>Printer Interface</b>		Compliant with Centronics (parallel)	<b>NEW!</b> USB
<b>Flex Network Interface</b>		✓ → See 2.5.8	
<b>USB Host Interface</b>		-	<b>NEW!</b> ✓

**1.3 Specifications of GLC-2400T and GP-3400T-FN1M**

		GLC-2400T	GP-3400T-FN1M
			
<b>Display Type</b>		TFT Color LCD	
<b>Display Colors</b>		256 colors	<b>UP!</b> 65536 colors
<b>Display Resolution</b>		VGA (640 × 480 pixels)	
<b>Panel Cut Dimensions (mm)</b>		204.5 (W) × 159.5 (H)	
<b>External Dimensions (mm)</b>		215 (W) × 170 (H) × 60 (D)	
<b>Touch Panel Type</b>		Matrix	Resistive Film (Analog) <b>NEW!</b> → See 2.3
<b>Serial Interface</b>	<b>COM1</b>	D-Sub 25 pin (female) RS-232C/422	<b>NEW!</b> D-Sub 9 pin (male) RS-232C/485 (422) Compatible
	<b>COM2</b>	D-Sub 9 pin (male) RS-232C	<b>NEW!</b> D-Sub 9 pin (female) RS-485 (422) Compatible
<b>Memory</b>	<b>Application</b>	4MB	<b>UP!</b> 8MB
	<b>SRAM</b>	256KB	<b>UP!</b> 320KB
<b>Control Memory</b>	<b>Program</b>	128KB	<b>UP!</b> 132KB
	<b>SRAM</b>	64KB	
<b>Ethernet Interface</b>		10BASE-T	10BASE-T/ <b>UP!</b> 100BASE-TX
<b>CF Card Interface</b>		✓	
<b>Printer Interface</b>		Compliant with Centronics (parallel)	<b>NEW!</b> USB
<b>Flex Network Interface</b>		✓ → See 2.5.8	
<b>USB Host Interface</b>		-	<b>NEW!</b> ✓

**1.4 Specifications of GLC-2300T/L and GP-3300T/L-FN1M**

		GLC-2300T/2300L	GP-3300T/3300L-FN1M
			
Display Type	2300T	TFT Color LCD	
	2300L	Monochrome LCD	
Display Colors	2300T	256 colors	<b>UP!</b> 65536 colors
	2300L	2 levels / 8 levels	<b>UP!</b> 16 levels
Display Resolution		QVGA (320 × 240 pixels)	
Panel Cut Dimensions (mm)		156 (W) × 123.5 (H)	
External Dimensions (mm)		171 (W) × 138 (H) × 60 (D)	167.5 (W) × 135 (H) × 59.5 (D)
Touch Panel Type		Matrix	Resistive Film (Analog) <b>NEW!</b> → See 2.3
Serial Interface	COM1	D-Sub 25 pin (female) RS-232C/422	<b>NEW!</b> D-Sub 9 pin (male) RS-232C/485 (422) Compatible
	COM2	D-Sub 9 pin (male) RS-232C	<b>NEW!</b> D-Sub 9 pin (female) RS-485 (422) Compatible
Memory	Application	2MB	<b>UP!</b> 6MB
	SRAM	256KB	<b>UP!</b> 320KB
Control Memory	Program	128KB	<b>UP!</b> 132KB
	SRAM	64KB	
Ethernet Interface		10BASE-T	10BASE-T/ <b>UP!</b> 100BASE-TX
CF Card Interface		✓	
Printer Interface		Compliant with Centronics (parallel)	<b>NEW!</b> USB
Flex Network Interface		✓ → See 2.5.8	
USB Host Interface		-	<b>NEW!</b> ✓

## Chapter 2. Compatibility of Hardware

### 2.1 Locations of connectors

Connector locations on the GLC2000 series and the GP3000 series C class FLEX NETWORK type are as follows.

#### 2.1.1 Rear of GLC-2600/2500 and GP-3600/3500-FN1M

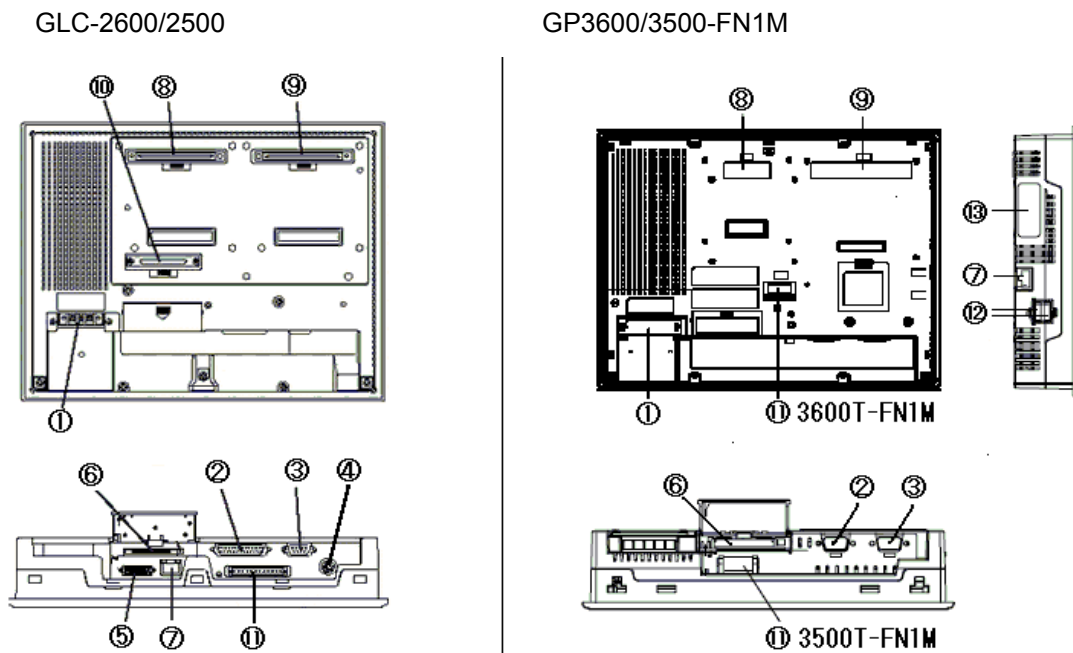

#### 2.1.2 Rear of GLC-2400 and GP-3400-FN1M

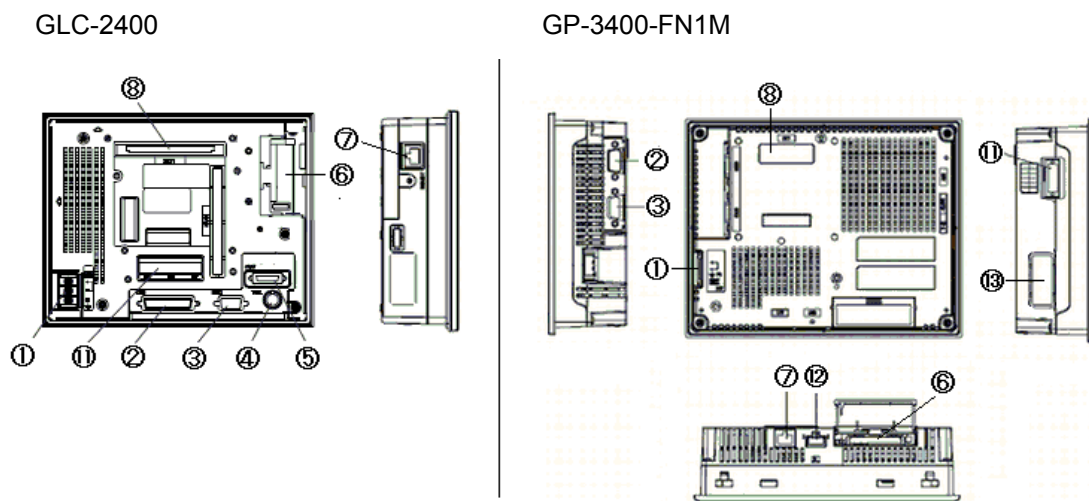

2.1.3 Rear of GLC-2300 and GP-3300-FN1M

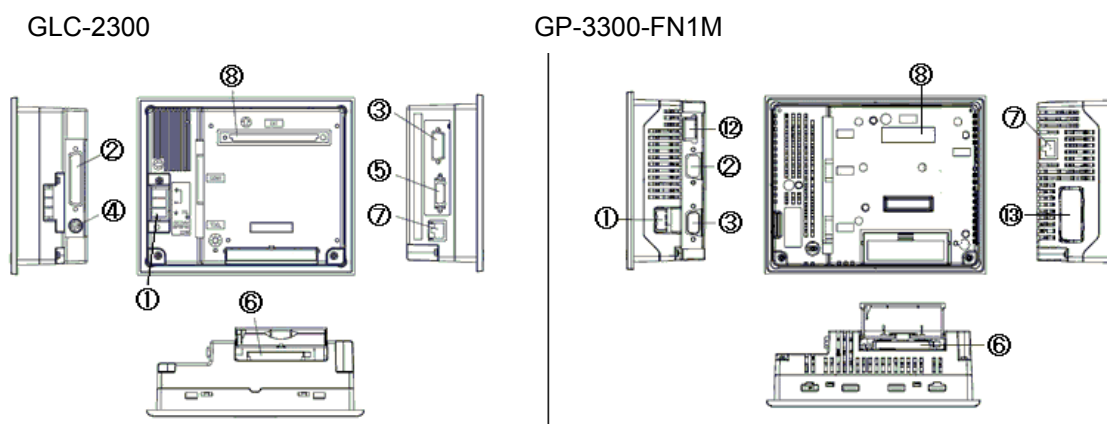

Interface names (applicable to all models)

	GLC2000 Series	GP3000-FN1M Series
1	Power Input Terminal Block	Power Input Terminal Block (AC type) Power Plug Connector (DC type)
2	Serial Interface (COM1)	
3	Expansion Serial Interface (COM2)	Serial Interface (COM2)
4	Tool Connector	-
5	Printer Interface	-
6	CF Card Interface	
7	Ethernet Interface	
8	Expansion Unit Interface 1	
9	Expansion Unit Interface 2 *1	
10	Expansion CF Card Interface *2	-
11	Screw Lock Terminal Block (Flex Network Interface, AUX)	Auxiliary Input/Output (AUX), Voice Output Interface
12	-	USB Host Interface
13	-	Flex Network Interface

\*1: GLC2400T,2300T/L,GP3400T,3300T/L doesn't have this interface.

\*2: GLC2400T,2300T doesn't have this interface.

## **2.2 About panel cut dimensions (3500T)**

GP-3500T is designed smaller for space savings. The panel cut dimensions of GP-3500T are different from those of GLC-2500T. Please prepare an attachment (model: CA4-ATM10-01) for installation of GP-3500T.

## **2.3 Touch panel specifications**

The touch panel type for the GP3000 series is “Resistive film (Analog) type”. The resistive film (Analog) type doesn’t recognize the touch input even if you touch two points at the same time. Please do not touch two points at the same time. If you applied the two-point touch input on the GLC2000 series, we recommend you to change to the one-point touch input using the switch delay function.

## **2.4 About transfer cable**

To transfer screen data to the series, use an Ethernet cable or a USB transfer cable for the GP3000 series (model: CA3-USBCB-01). Please note that any commercial USB cable cannot be used. The tool port and a transfer cable for the GP2000 series (\*1) are used for screen data transfer to the GP2000 series, but they are not available with the GP3000 series.

\*1: Models of transfer cable for the GP2000 series: GPW-CB02, GPW-CB03, GP430-CU02-M, etc.

## **2.5 About interfaces**

### **2.5.1 Serial interface**

The COM1 port on the GP3000 series is D-Sub 9 pin male and the COM2 port is D-Sub 9 pin female. The COM1 port on the GLC2000 series is D-Sub 25 pin male and the COM2 port is D-Sub 9 pin male. The pin assignment and the shape of male/female connector are different from those of the GP3000 series. Check if you can use the cable with the ST3000 series on Otasuke Pro! “Connectable Controllers for GP3000 Series.”

<http://www.pro-face.com/otasuke/qa/gp3000/replace/connect/connect.php>

### **2.5.2 AUX output**

The GP3000 series is equipped with AUX (external output), but the shape of the AUX (external output) connector is different from that of GLC-2600/2500/2400. Please check wiring for the AUX interface before you replace the units.

### **2.5.3 Flex Network interface**

The Flex Network communication interface on the GP3000 series and that of the GLC2000 series differ in size. The Flex Network DIO connector used with the GLC2000 series cannot be used. For the replacement from the GLC2000 series to the GP3000 series, remove the Flex Network cable from the GLC2000 series and replace it to the GP3000 series.

In the GP3000 series, you can set up to 63 stations, 256 points of bit variable input, 256 points of bit variable output, 64 points of integer variable input, and 64 points of integer variable output. If you have set more than 256 points of bit input for the GLC2000 series, an error message will appear and the data transfer will be failed.

## **2.6 Peripheral units and option units**

### **2.6.1 Barcode reader connection**

The GP3000 series is not equipped with a tool port. A barcode reader connected from the tool port on the GLC2000 series cannot be used. However, the GP3000 series allows you to connect a barcode reader on its USB interface or its serial interface.

### **2.6.2 Printer connection**

The GP3000 series is not equipped with the Centronics (parallel) interface for the printer. Please prepare a conversion cable to convert the USB of the GP3000 series to the Centronics interface if you connect the printer to the GP3000, which was connected to the Centronics interface on the GLC2000 series. The GP3000 series allows you to connect a printer on its Ethernet port as well as on its USB port.

### **2.6.3 Expansion unit**

The expansion bus unit for the GP3000 is different from that of the GLC2000 series. Please note that the expansion unit, such as a CC-LINK unit, used with GLC2000 series cannot be used.

For the details of the expansion units for the GP3000 series currently available, refer to <http://www.pro-face.com/product/gp/gp3000/option/>

### **2.6.4 Amplifier connection**

The GP3000 series doesn't have the line output function. If you connected from the line output on the AUX interface of the GLC2000 series to an amplifier, replace your speaker to one with a built-in amplifier and use the speaker output.

### **2.6.5 Front maintenance unit**

The front maintenance unit (GP077-CFFM10) for the GLC2000 series is not available with the GP3000 series. Please use a CF card with the CF card interface equipped on the display unit.

### **2.7 About body material/color**

The body material of GP-3600T/3500T/3400T is aluminum. That of the GLC2000 series is resin. Please note that the material characteristic and the color are different.

### **2.8 About power connector**

The power connector for the DC type on the GP3000 series is a screw lock terminal block. If you replace from the GLC2000 series, change the power cable.

The power connector for the AC type is the same as that on the GLC2000 series, however, the position of FG has been changed.

### **2.9 About power consumption**

Only as for the AC type, the power consumption of the GP3000 series and that of the GLC2000 series are different. Please check the power supply capacity that is supplied to the display unit.

**Chapter 3. Replacement Procedure**

**3.1 Work Flow**

► To change the equipment designed for the GLC2000 series to the GP3000 series C class FLEX NETWORK type

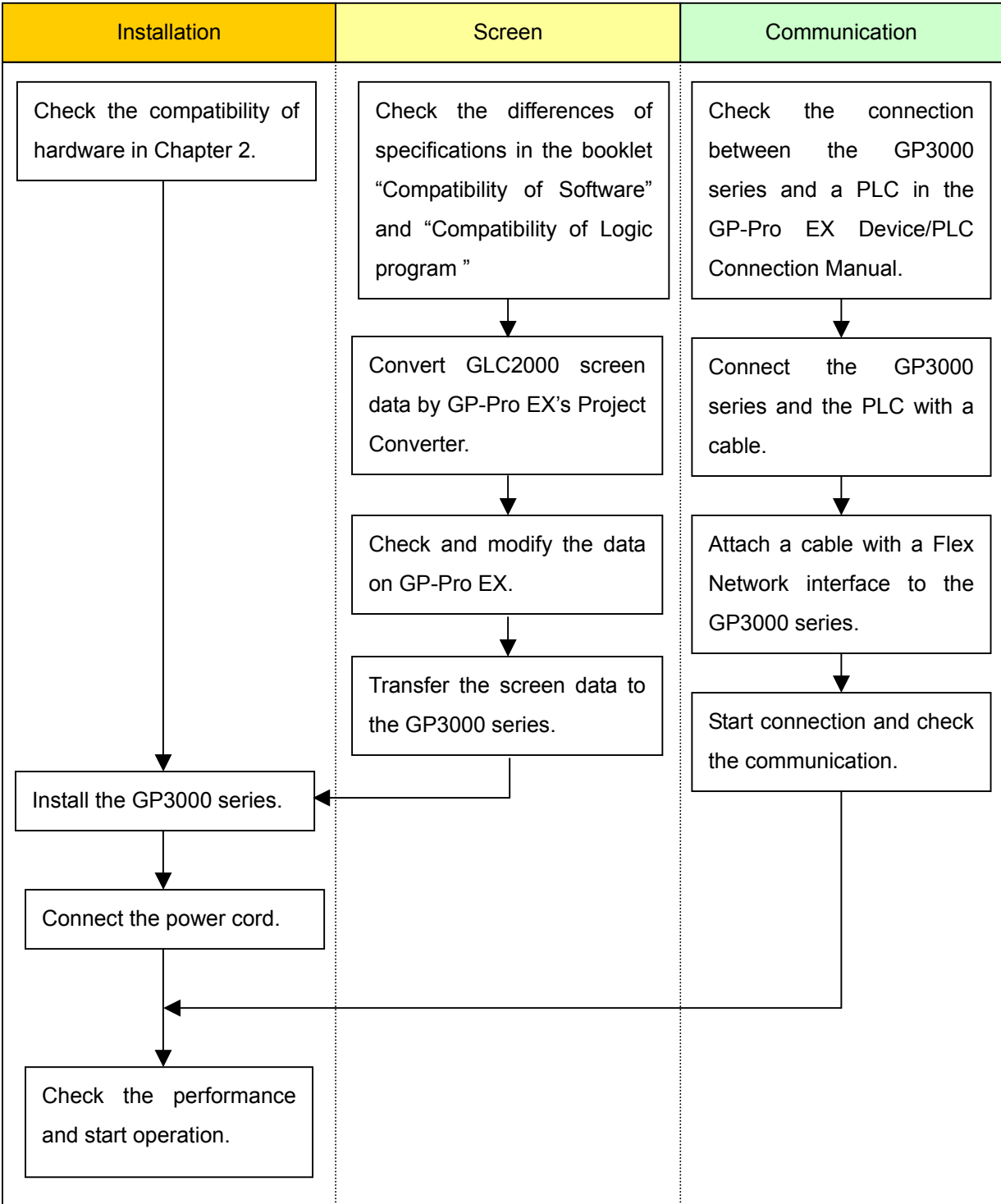

► To replace the GLC2000 series mounted to the equipment to the GP3000 series C class FLEX NETWORK type

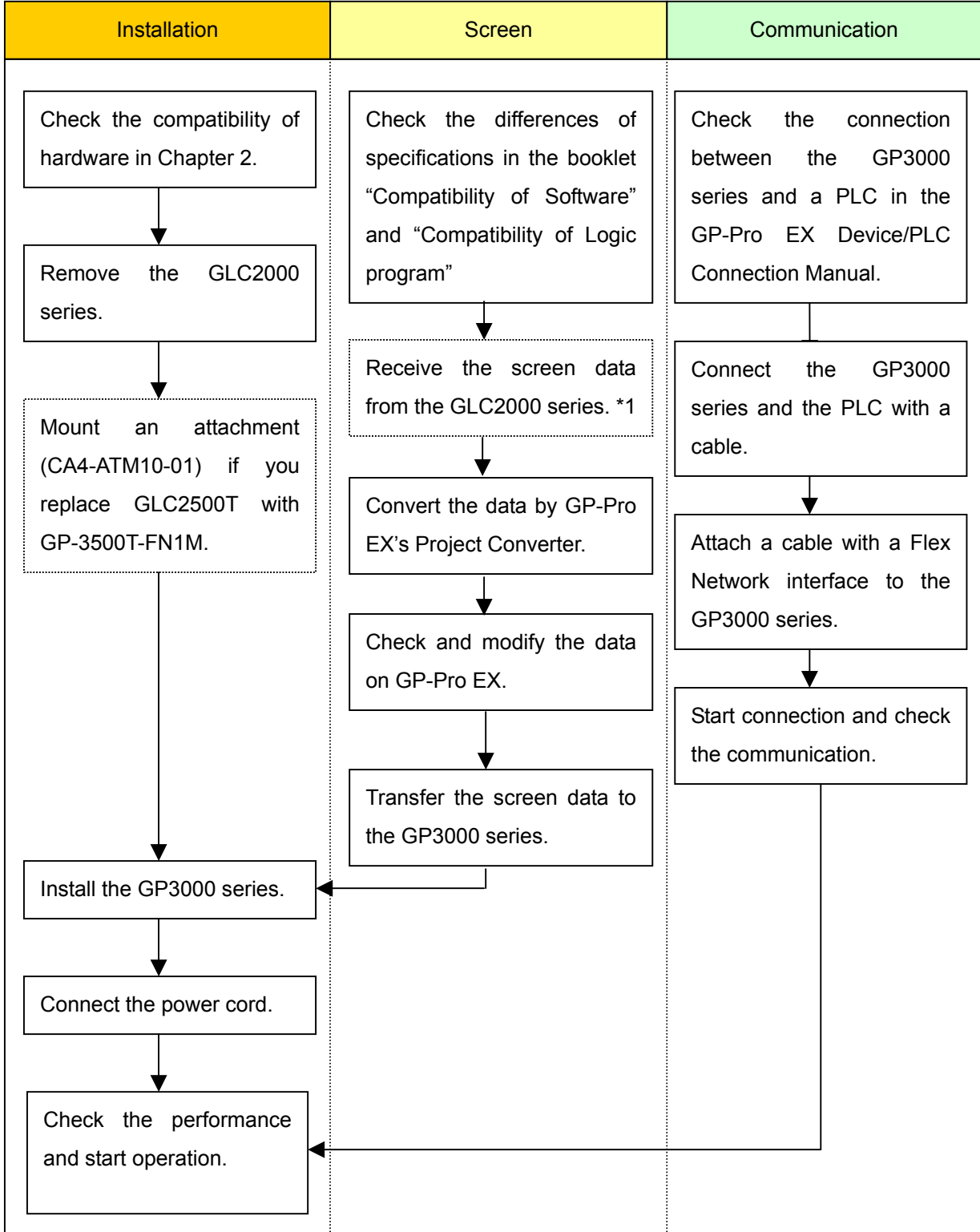

\*1: This step is required if screen data is saved only in the GP unit, not in any other device.

### 3.2 Preparation

Requirements for receiving screen data from the GLC2000 series (*1)	PC in which the following version or higher of C-package GP-PRO/PB3 is installed (*2)	
	GLC2300T/L GLC2400T GLC2600T	C-Package01 GP-PRO/PBIII for Windows Ver.6.0 or higher
	GLC2500T	C-Package03 GP-PRO/PBIII for Windows Ver. 7.0 or higher
	Transfer cable (The following three types of cable are available.)	
	<ul style="list-style-type: none"> <li>• GPW-CB02 (D-sub 9-pin to the PC)</li> <li>• GPW-CB03 (USB to the PC) *3</li> <li>• GP430-CU02-M or GPW-SET</li> </ul>	
	The GLC2000 series also allows you to transfer screen data via Ethernet or CF card.	
Requirements for converting screen data of the GLC2000 series and transferring to the GP3000 series	PC in which GP-Pro EX is installed	
	Transfer cable (model: CA3-USBCB-01) The GP3000 series C class FLEX NETWORK type also allows you to transfer screen data via Ethernet, CF card or USB flash drive.	

\*1: This step is required if screen data is saved only in the GLC unit, not in any other device.

\*2: The software version must be the same or higher than the version that you used when creating screen data for the GLC2000 series.

We recommend you to upgrade to the latest version, which is C-Package 03 GP-PRO/PB3 for Windows Ver.7.29. If the version of the software that you currently use is C-Package 03 GP-PRO/PB3 for Windows Ver.7.0, upgrade it on our website Otasuke Pro!

\*3: GPW-CB03 is compliant with GP-PRO/PBIII for Windows Ver. 6.23 (C-Package02 SP2) or later. Also, to use it, you may need to [install the driver](#).

### 3.3 Receive screen data from the GLC2000 series

This section explains, as an example, how to receive screen data from the GLC unit using a transfer cable GPW-CB02 or GPW-CB03. If you have backed up screen data, this step is unnecessary; skip to the next section “3.4 Convert screen data with the Project Converter.”

1. Connect a transfer cable to the GLC2000 series.

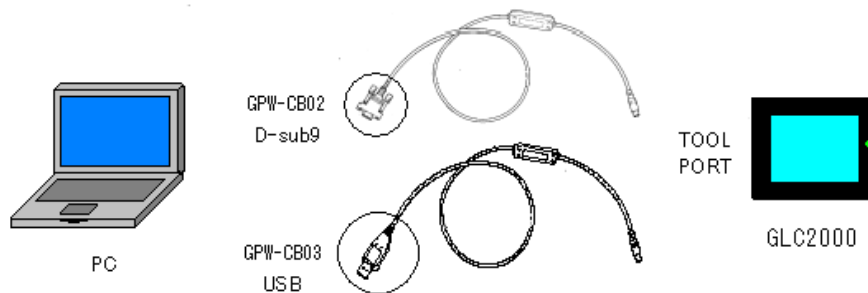

2. Start up GP-Pro/PBIII C-Package and click the [Transfer] icon on the Project Manager. (Specify a desired project file.)



3. On the [Transfer] window, select the [Setup] menu and click [Transfer Settings...].

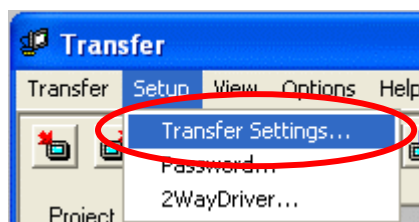

4. In the Communication Port field, select [COM], specify the COM port to which the cable is connected, and click [OK].

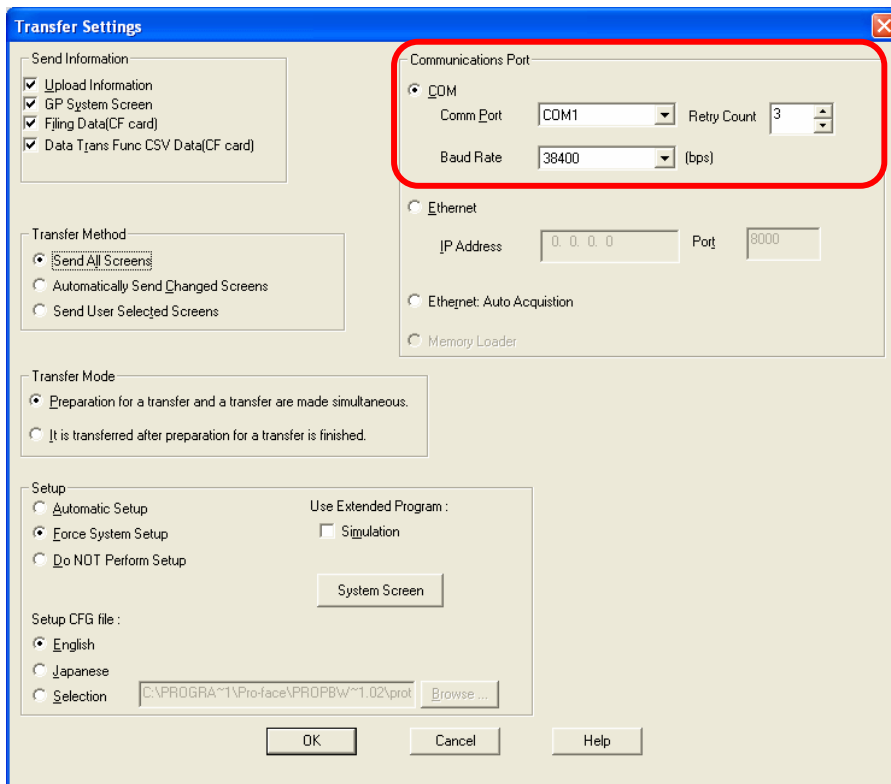

**If you use a USB transfer cable (GPW-CB03)...**

You can check the COM port for the USB transfer cable (GPW-CB03), which is assigned to the PC with the Device Manager of Windows.

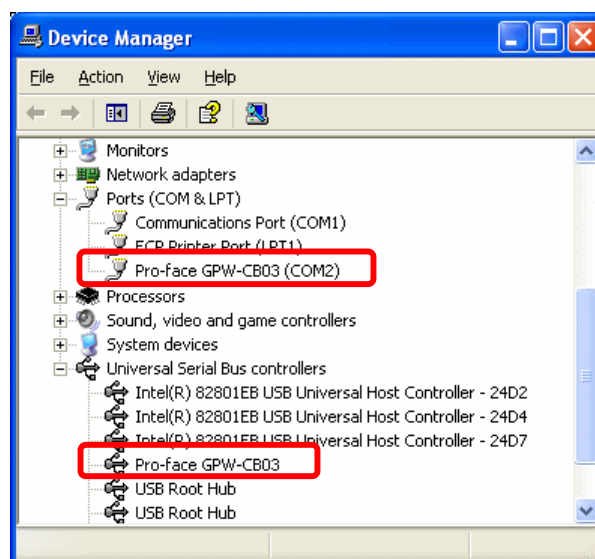

5. Select the [Transfer] menu and click [Receive...].

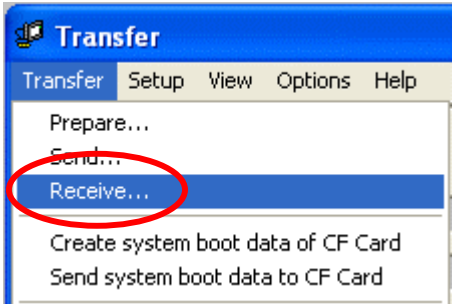

6. Specify the location to save the received screen data in and the project file name and save.

**In case there is no Upload Information...**

“Upload Information” is the necessary information to receive screen data from the display unit. It needs to be included in screen data when transferring screen data to the display unit beforehand. The Upload Information is sent to the display unit by default, however, you may check off the box of Upload Information to prevent screen reception by a third party.

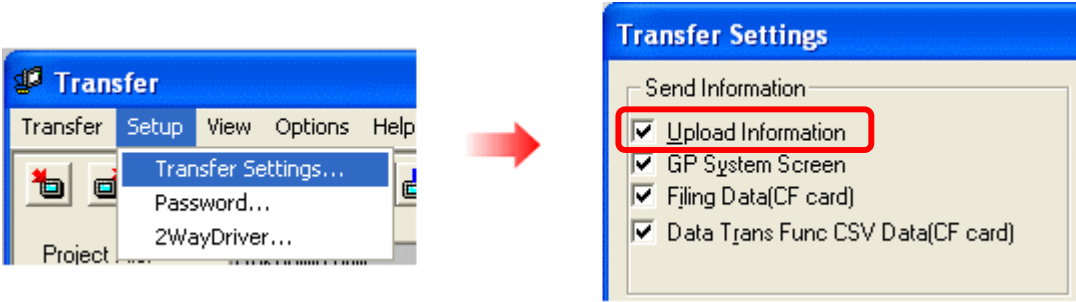

The image shows two screenshots. On the left, the 'Transfer' menu is open with 'Transfer Settings...' selected. A red arrow points to the right, where a 'Transfer Settings' dialog box is shown. In the dialog box, under the 'Send Information' section, the 'Upload Information' checkbox is checked and highlighted with a red box. Other checked options include 'GP System Screen', 'Filing Data(CF card)', and 'Data Trans Func CSV Data(CF card)'.

In this case, a message, which indicates there is no Upload Information,” appears and you cannot receive the data.

You can check if the Upload Information has been sent or not in the following way.

Enter into the GP’s Offline mode. If there are 2 asterisk (\*) marks in the Main menu as below, the Upload Information has been sent. If not, there is no Upload Information sent.

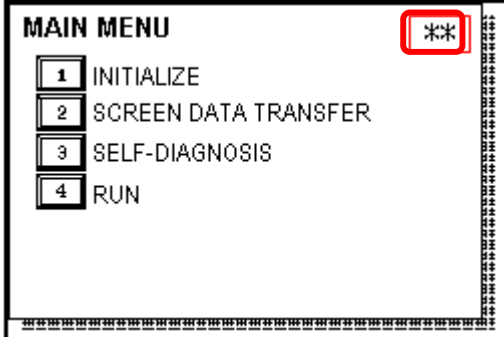

The image shows a 'MAIN MENU' screen with four options: 1 INITIALIZE, 2 SCREEN DATA TRANSFER, 3 SELF-DIAGNOSIS, and 4 RUN. In the top right corner of the menu area, there are two asterisks (\*\*), which are enclosed in a red box.

### 3.4 Convert screen data with the Project Converter

Convert a project file (\*.prw) for the GLC2000 series with the GP-Pro EX's Project Converter.

1. Click the [Start] button, select the [All Programs] ([Programs] on Windows® 2000 menu → [Pro-face] → [GP-Pro EX\*.\*\*]. (The version of the software you use will be shown in \*.\*.)

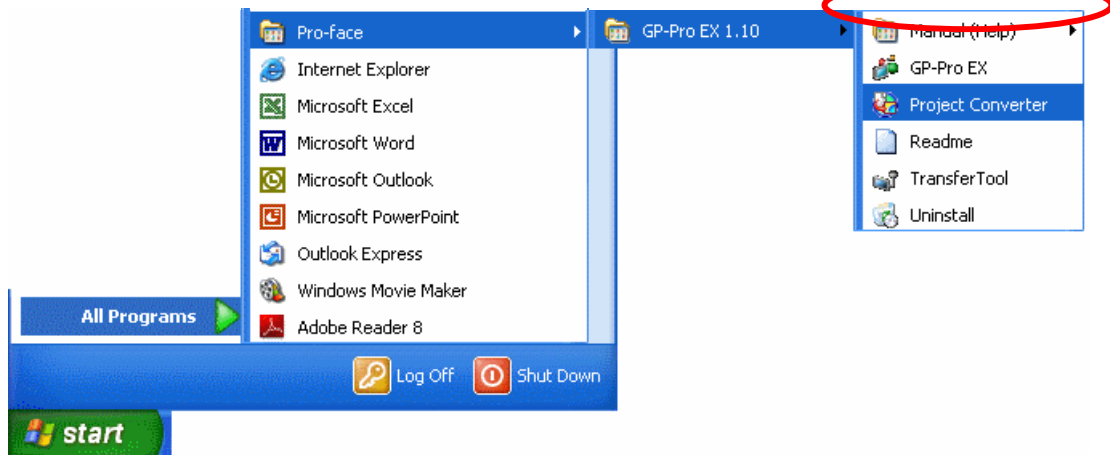

2. The Project Converter starts up and the [Project Converter] dialog box opens. Select [Project File (\*.PRW)] in the [Data Type].

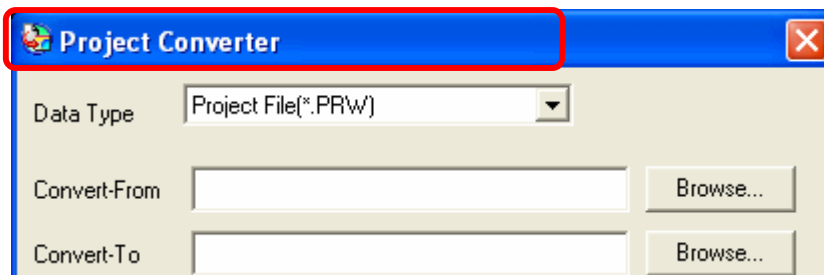

**NOTE**

To convert a file of the Pro-Control Editor, select "Logic File (\*.wll).  
 To convert a part program file (\*.wlp) or a subroutine program (\*.wlf) file, save it as a project file (\*.prw) with GP-PRO/PBIII first and then convert.

3. Designate a GP-PRO/PBIII for Windows' project file (\*.prw) in [Convert-From].  
 Click the [Browse...] button and select a project file (e.g.: "Project system A.prw"). Click [Open], and the file will be set in [Convert-From].

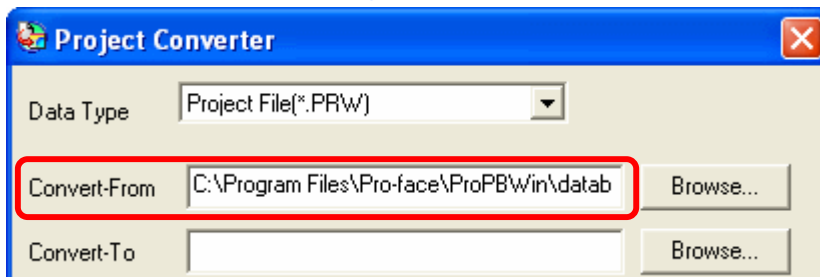
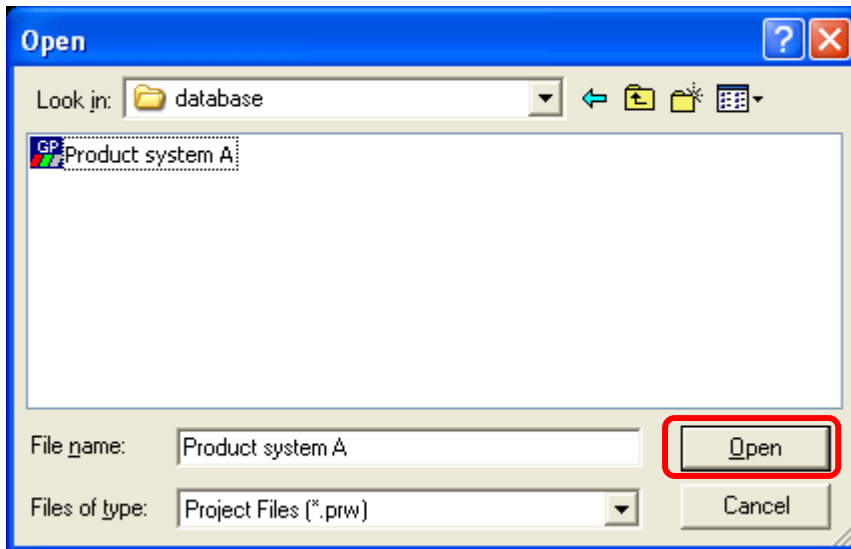
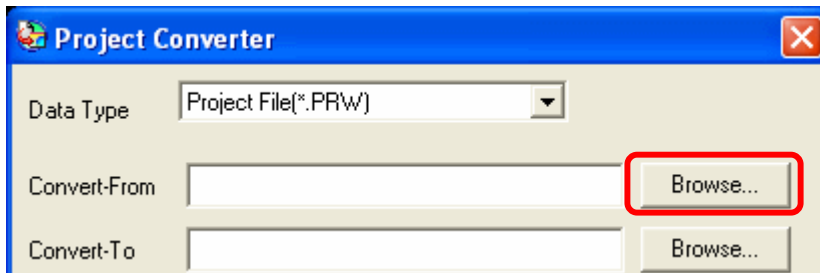

4. In [Convert-To], designate a GP-Pro EX's project file (\*.prx). Click the [Browse...] button and enter a new [File Name] (e.g.: "Product system A.prx"). Click [Save], and a new project file will be set to [Convert-To].

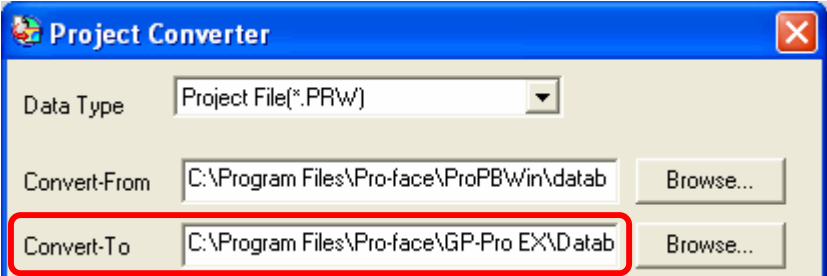
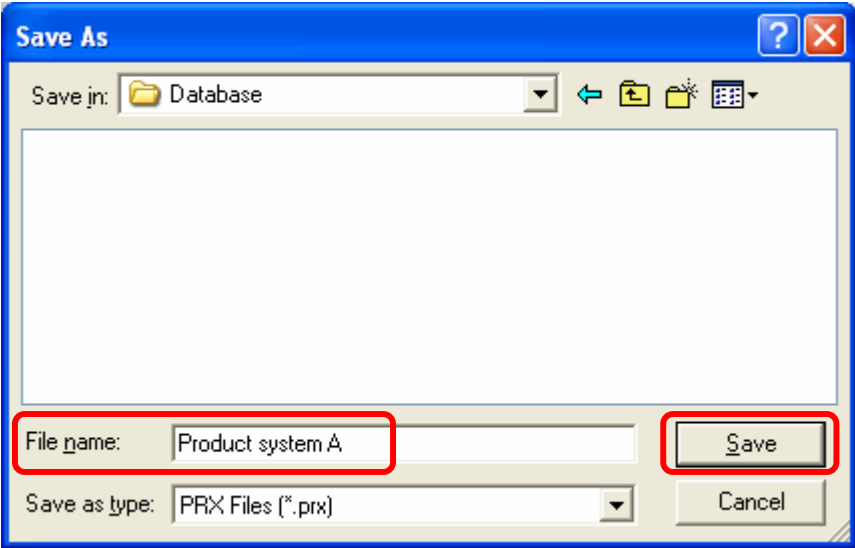
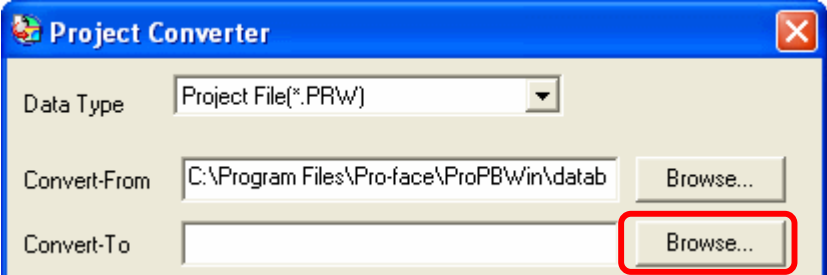

NOTE

- Depending on the model you are converting from, the [Convert-From Type] dialog box may display where you can select the type and the model.
- When a convert-to file exists, the window that confirms whether or not to overwrite the file is displayed.

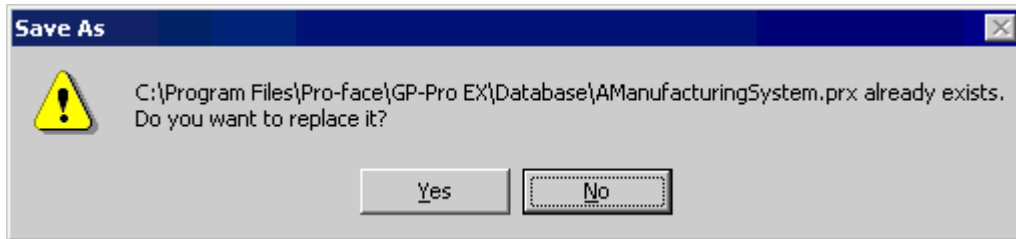

5. Click [convert] and start the conversion.

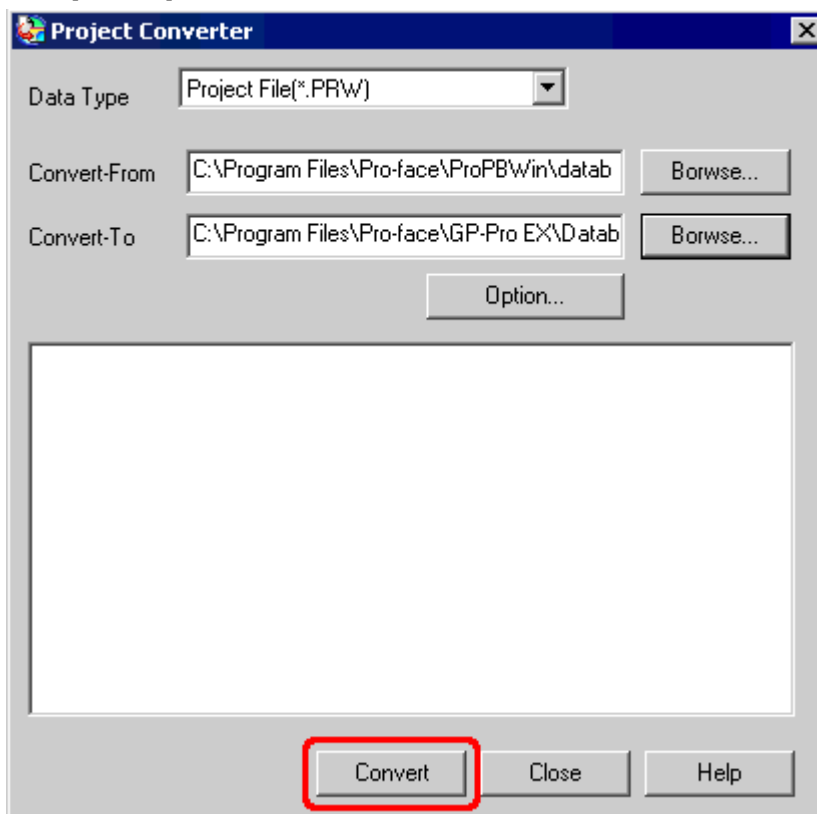

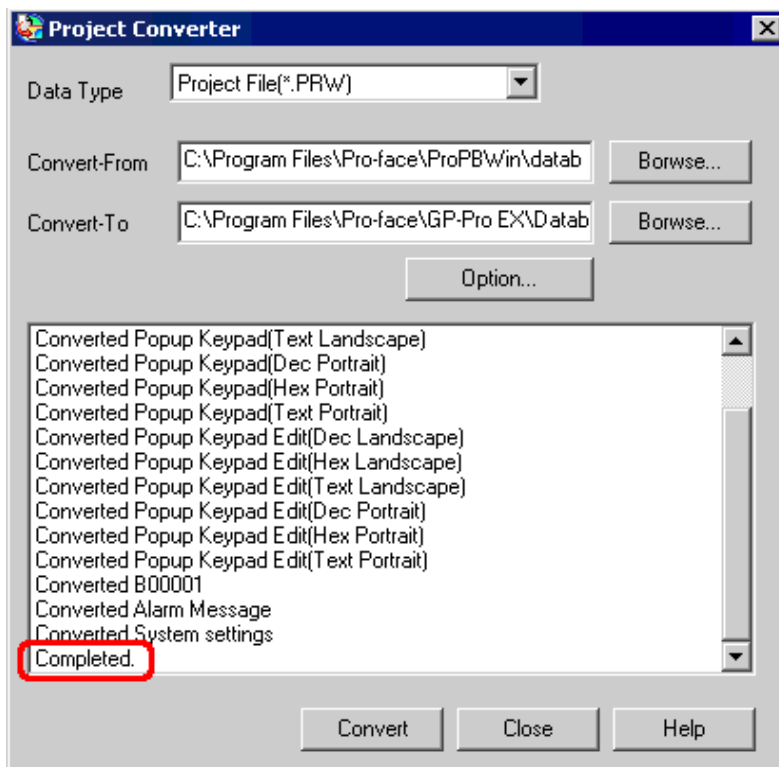

**NOTE**

- Depending on the model you are converting from, the [Convert Destination] dialog box may appear and you can select the type and the model.
- If the following dialog box appears, set a CF card output folder.

→ [See the next page](#)

- ◆ [Convert GP-PRO/PBIII for Windows' "Destination CF Card Folder"](#)

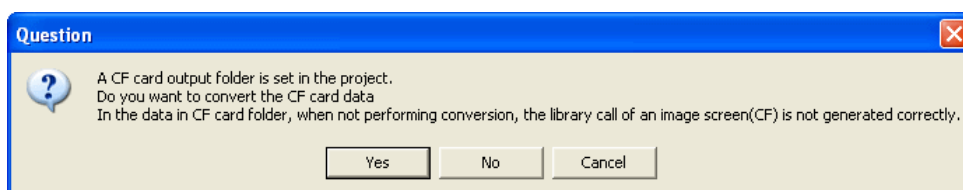

6. After conversion, the [Save convert information] dialog box appears. If you click [Save], you can save the conversion information in a text file.

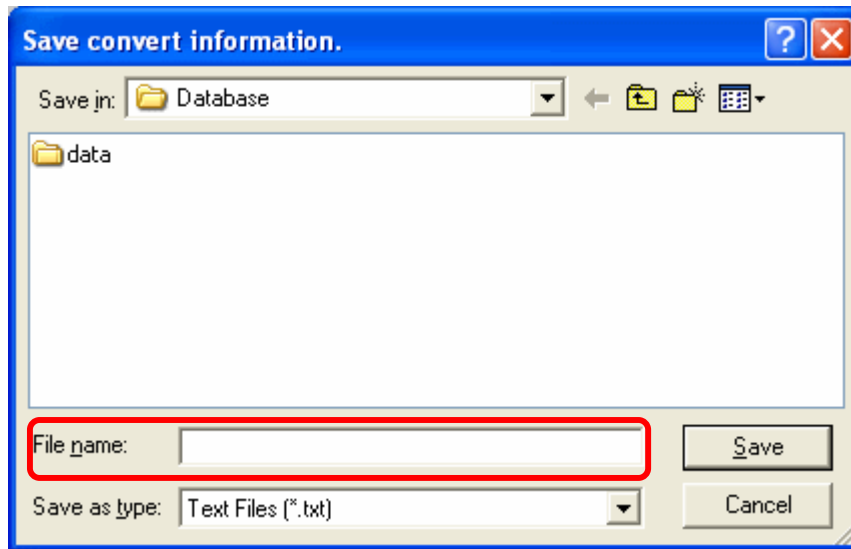

7. Click [Close] to close the [Project Converter] dialog box.

◆ Convert GP-PRO/PBill for Windows' "Destination CF Card Folder"

If you convert a project file (\*.prw) with a destination CF card folder designated in the step 5, the Question dialog box whether or not to designate the destination CF card folder for the convert destination appears again.

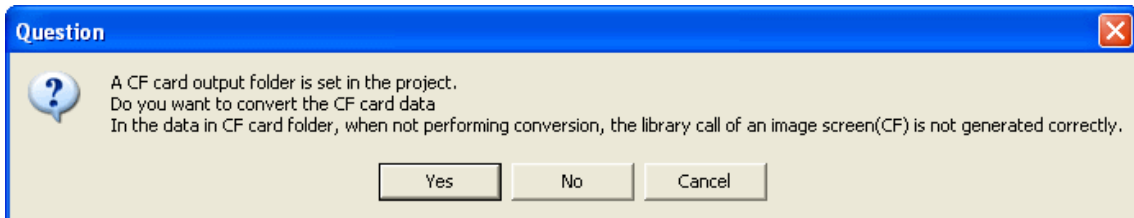

Select a folder (e.g.: "Database") and click [OK].

If you click the [Make New Folder] button, you can create a new folder at any location.

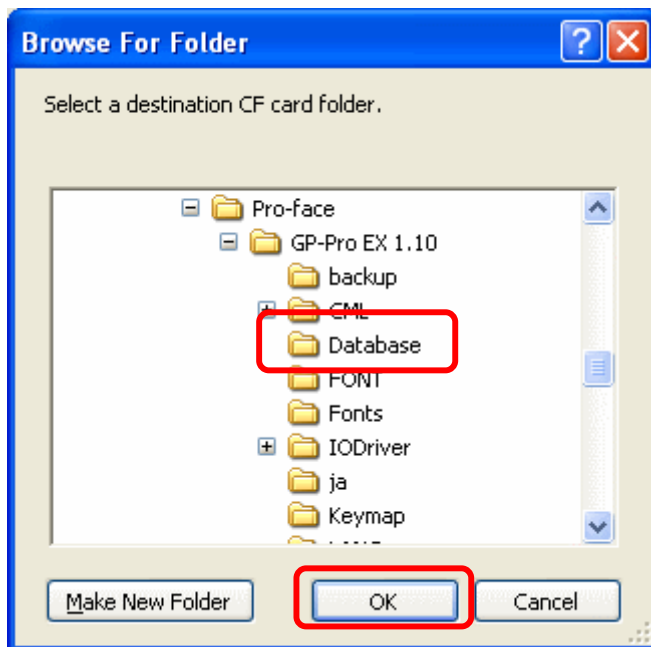

**IMPORTANT**

In the [Question] dialog box, be sure to select [Yes] and specify the destination folder. If you select [No], images will not be called correctly.

### 3.6 Transfer screen data to the GP3000 series

Transfer the converted project file to the GP3000 series. You can transfer data to the GP3000 series via USB transfer cable, Ethernet cable, CF card, or USB flash drive. Here, this section explains, as an example, how to transfer screen data by USB transfer cable (model: CA3-USBCB-01).



PC



CA3-USBCB-01



GP3000

1. Connect your PC and the GP3000 series with a USB transfer cable. If the driver of the cable has not been installed on your PC, a dialog box will appear. Please follow the instructions.

#### NOTE

The “Hardware Installation” dialog box as follows may appear during installing the driver of a USB depending on the security level of Windows XP. Click [Continue Anyway] to start installing the driver for CA3-USBCB-01. When installation is completed, click [Finish].

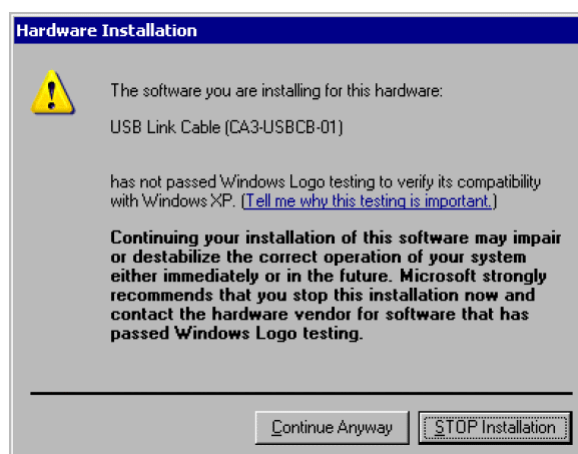

2. Turn on the display unit's power. The "Initial Start Mode" screen will appear on the display unit.

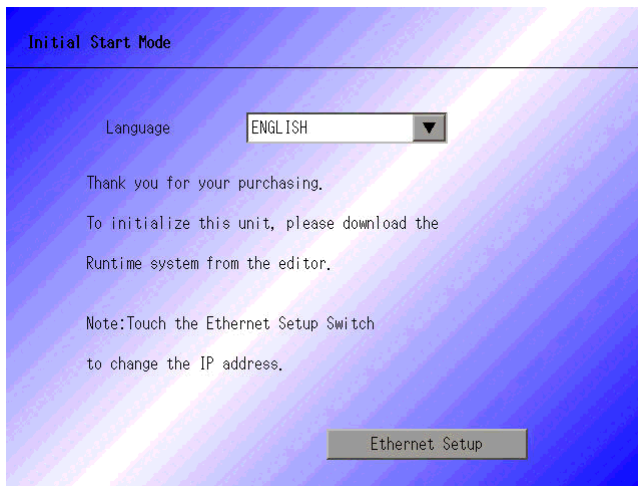

This screen will appear when you first connect the display unit's power code. After transferring a project file once, this screen will not appear again.

3. On the GP-Pro EX's State Toolbar, click the [Transfer Project] icon to open the Transfer Tool.

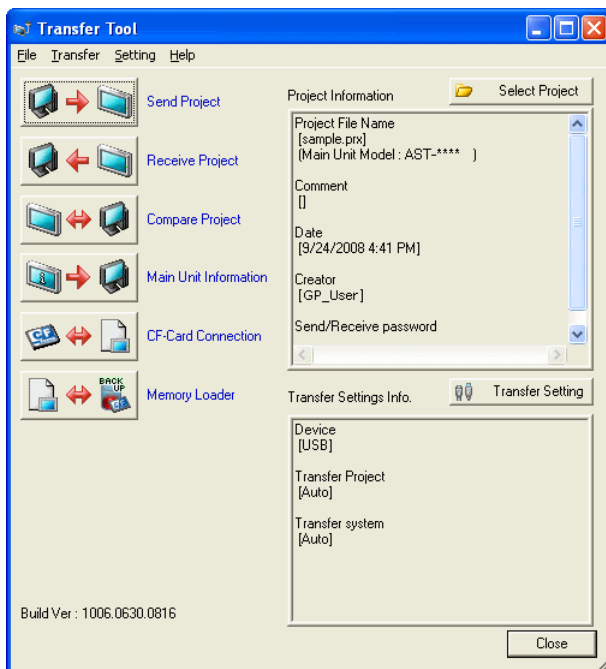

4. Check the project file name and other data to be transferred in the Project Information. To transfer a different project file, click the [Select Project] button and select a project file.

5. Make sure that the [Device] is set to [USB] in the “Transfer Settings Info.” If not, click the [Transfer Setting] button to open the “Transfer Settings” dialog box. Select [USB] in the Communication Port Settings field and click [OK].

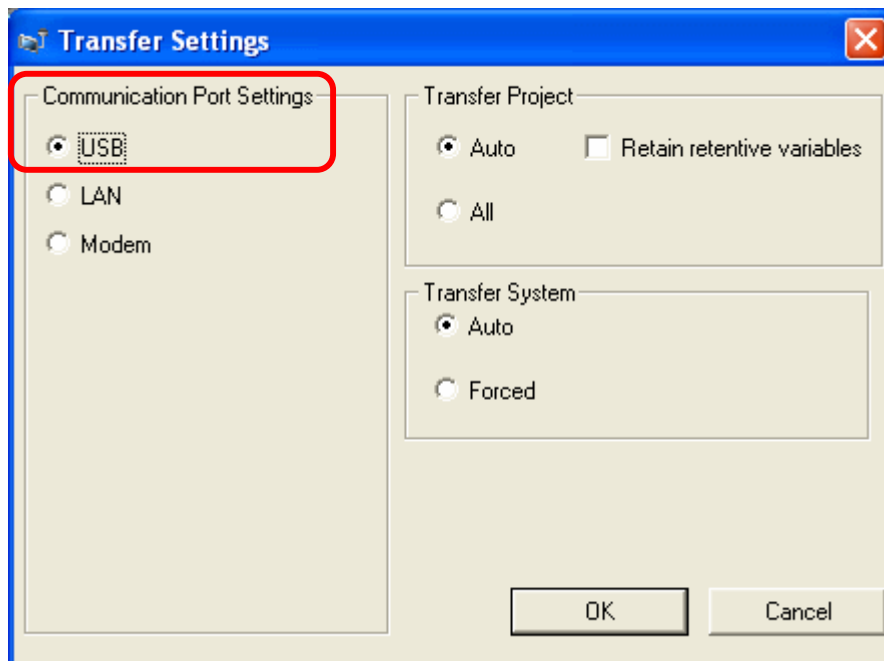

6. Click [Send Project] to start transfer. When the following dialog box appears, click [Yes]. This dialog box doesn't appear when the same project file is sent again.

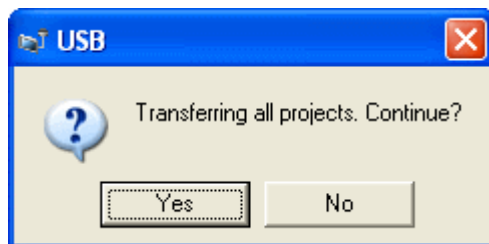

- The following dialog box appears during transfer and you can check the communication status. (The display unit enters the Transferring mode and communication with the device such as a PLC is terminated.)

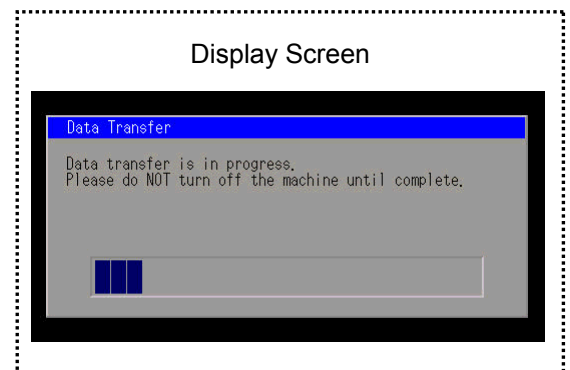
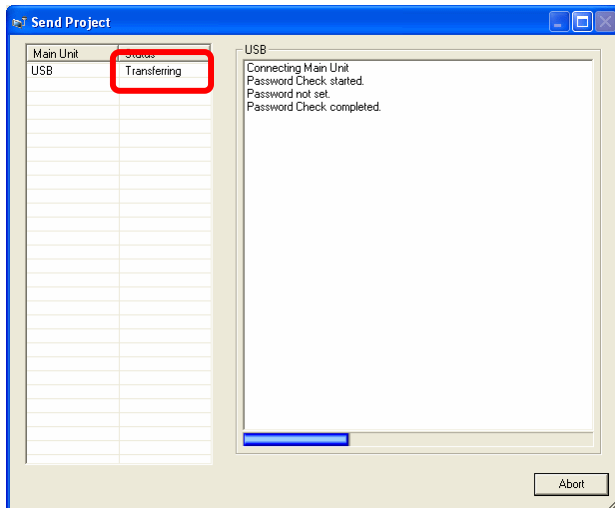

- When transfer is completed, the status displayed in the dialog box will change from [Transferring] to [Complete Transfer]. Click [Close] to close the dialog box. (The display unit will be reset and a screen of the transferred project file will be displayed.)

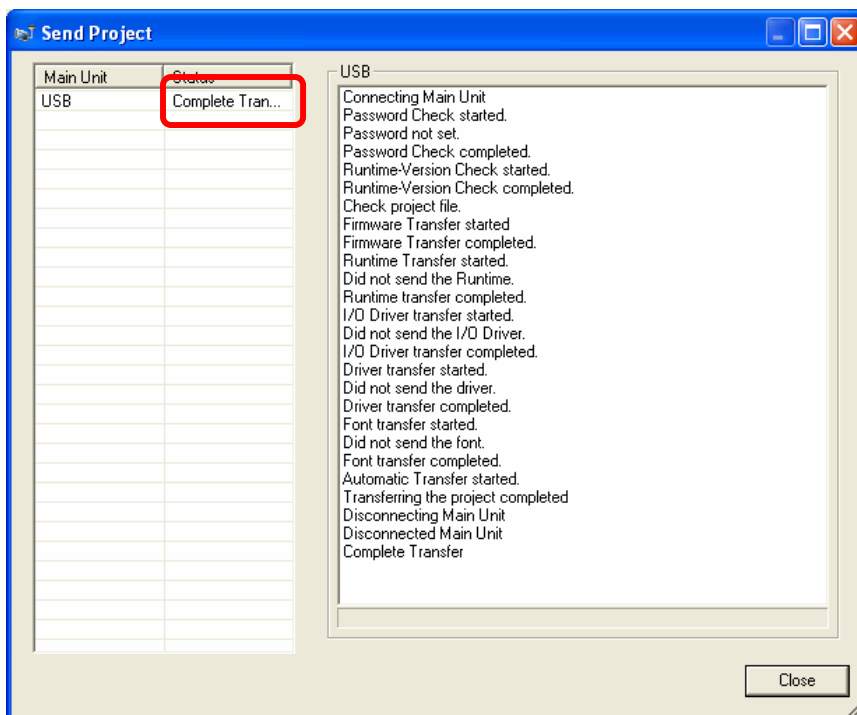

- Close the Transfer Tool.

### 3.6 Differences after conversion

#### 3.6.1 Differences of screen data

Check the differences of screen data after conversion. For the details of each item, refer to the booklet “Compatibility of Software” or visit our website

<http://www.pro-face.com/otasuke/qa/gp3000/replace/soft.htm>.

#### Compatibility of Software

1	Touch Panel Type
2	Compatibility of Bit Switch
3	Compatibility of Trend Graph
4	Compatibility of K Tag (Input Order)
5	Compatibility of K Tag (Difference of Writing)
6	Compatibility of K Tag (Indirect Setting)
7	Compatibility of N Tag
8	Precautions for using the switch for [History Data Display] of Trend Graph on the window
9	About the performance when a window is overlapping on a momentary switch
10	About the performance when display area of the system window is overlapping
11	Change of Tag Process
12	Compatibility of Text
13	Compatibility of Fill
14	Compatibility of CF Card
15	Precautions for conversion when filing data is saved in a CF card
16	Precautions for setting “Color Settings” to [256 Colors without blinking]
17	Precautions for loading a part with “L Tag (Library Display)”
18	Compatibility of MRK files and CPW files
19	Compatibility of VM Unit Settings
20	Compatibility of Extended SIO Script
21	Compatibility of Sound Data
22	Compatibility of Device Monitor
23	Compatibility of J Tag and R Tag

#### 3.6.2 Differences of screen data

For the details of conversion of the logic program, refer to the booklet “Compatibility of Logic Program” or visit our website

[http://www.proface.co.jp/otasuke/circle/conv\\_3000/soft/logic/convert\\_top.html](http://www.proface.co.jp/otasuke/circle/conv_3000/soft/logic/convert_top.html).

**Compatibility of Logic Program**

1. Comparisons of Restriction
1-1 Performance Specs
2. Differences of Settings
2-1 Differences of settings of Constant Scan
2-2 Differences of settings of Controller Auto Start
2-3 The storing order of character string data
3. Settings Changes
3-1 Ladder Monitor Screen
3-2 Conversion when a Logic Program error occurs
3-3 Converting Logic File (*.WLL)
3-4 DIO Driver
3-5 Differences when specifying Integer Variable Bits
3-6 Initial Value Settings of Variables
3-7 Converting variables to be undefined addresses
3-8 Array
3-9 Assigning array variables on Configure I/O
3-10 The case there is no driver assignment
4. Conversion of Variables/Instructions
4-1 Differences of Fix Variable Mode
4-2 Differences of LS variables
4-3 Temporary variables
4-4 Differences of PID instructions
4-5 Differences of system variables
4-6 Instruction conversion
4-7 When the second operand of the PID instruction is an integer constant
4-8 Values of variable "LS" and "LSS"
5. Conversion of Comments/Labels
5-1 Program comments
5-2 User label
5-3 Subroutine
5-4 Converting a project file including comments entered in the operation system in another language

## Chapter 4. Communication between GP3000 series and Device/PLC

This chapter explains about cables and wiring for communication between the GP3000/ /ST3000 series and a connection device such as PLC.

### 4.1 Driver list

#### NOTE

The followings are information as of October 2008.

More connectable drivers will be added. Please check our website “Otasuke Pro!” for the latest information.

Manufacturer	Series	PLC	
		GP3000	ST3000
Mitsubishi Electric Corporation	A Series CPU Direct	✓	✓
	A Series Ethernet	✓	-
	A Series Computer Link	✓	✓
	FX Series CPU Direct	✓	✓
	FX Series Computer Link	✓	✓
	Q Series CPU Direct	✓	✓
	Q Series QnU CPU Ethernet *1	✓	-
	Q/QnA Serial Communication	✓	✓
	Q/QnA Series Ethernet	✓	-
	QnA Series CPU Direct	✓	✓
	QUTE Series CPU Direct	✓	✓
OMRON Corporation	C/CV Series HOST Link	✓	✓
	CS/CJ Series Ethernet	✓	-
	CS/CJ Series HOST Link	✓	✓
YASKAWA Electric Corporation	MEMOBUS SIO	✓	✓
	MEMOBUS Ethernet	✓	-
	MP Series SIO (Extension)	✓	✓
	MP Series Ethernet (Extension)	✓	-
Hitachi IES Co., Ltd.	H Series Ethernet	✓	-
	H Series SIO	✓	✓
Matsushita Electric Works, Ltd.	FP Series Computer Link SIO	✓	✓
YOKOGAWA Electric Corporation	Personal Computer Link SIO	✓	✓

	Personal Computer Link Ethernet	✓	-
JTEKT Corporation (Former name: Toyoda Machine Works)	TOYOPUC CMP-LINK SIO	✓	✓
	TOYOPUC CMP-LINK Ethernet	✓	-
Fuji Electric Co., Ltd.	MICREX-F Series SIO	✓	✓
	MICREX-SX Series SIO	✓	✓
	MICREX-SX Series Ethernet	✓	-
GE Fanuc Automation	Series 90 Ethernet	✓	-
	Series 90-30/70 SNP	✓	✓
	Series 90-30/70 SNP-X	✓	✓
Siemens AG	SIMATIC S7 3964 ( R ) /RK512	✓	✓
	SIMATIC S7 MPI Direct	✓	✓
	SIMATIC S7 Ethernet	✓	-
	SIMATIC S5 CPU Direct	✓	✓
Rockwell Automation, Inc.	DF1	✓	✓
	EtherNet/IP	✓	-
	DH-485	✓	✓
KEYENCE Corporation	KV-700/1000/3000/5000 CPU Direct	✓	✓
	KV-700/1000/3000/5000 Ethernet	✓	-
	KV Series CPU Direct	✓	✓
	KZ10_80R/Tseries CPU Direct *1	✓	✓
Schneider Electric Industries	MODBUS SIO Master	✓	✓
	MODBUS TCP Master	✓	-
	Uni-Telway	✓	✓
	MODBUS Slave	✓	✓
SHARP MS Corporation	JW Series Computer Link SIO	✓	✓
	JW Series Computer Link Ethernet	✓	-
LS Industrial System	MASTER-K Series Cnet	✓	✓
	XGT Series FEnet	✓	-
	XGT Series Cnet	✓	✓
Mitsubishi Heavy Industries, Ltd.	DIASYS Netmation MODBUS TCP	✓	-
	MHI STEP3 Ethernet	✓	-
Saia-Burgess Controls Ltd.	SAIA S-Bus SIO	✓	✓
MEIDENSHA Corporation	UNISEQUE Series Ethernet	✓	-

FUNUC Ltd	Power Mate Series	✓	✓
Hitachi, Ltd.	S10V Series Ethernet	✓	-
	S10 Series SIO	✓	✓
TOSHIBA Machine Co., Ltd.	PROVISOR TC200	✓	✓
TOSHIBA Corporation	Computer Link SIO	✓	✓
	Computer Link Ethernet	✓	-
Koyo Electronics Co., Ltd.	KOSTAC/DL Series CCM SIO	✓	✓
	KOSTAC/DL Series MODBUS TCP	✓	-
FATEC AUTOMATION Corporation	FB Series SIO	✓	✓
MODBUS IDA	General MODBUS RTU SIO Master	✓	✓

Temperature Controller			
Manufacturer	Series	GP3000	ST3000
Yamatake Corporation	Digital Controller SIO	✓	✓
RKC Instrument Inc.	Temp. Controller MODBUS SIO	✓	✓
	Temperature Controller	✓	✓
OMRON Corporation	Temp. Controller CompoWay/F	✓	✓
Shinko Technos Co., Ltd.	Controller SIO	✓	✓
YOKOGAWA Electric Corporation	Personal Computer Link SIO	✓	✓
CHINO Corporation	Temp. Controller MODBUS SIO	✓	✓
Fuji Electric Systems Co., Ltd.	Temp. Controller MODBUS SIO *1	✓	✓

Inverter/ Servo			
Manufacturer	Series	GP3000	ST3000
Mitsubishi Electric Corporation	FREQROL Inverter *2	✓	✓
Sanmei Electric Co., Ltd.	Si/CutyAxisSeries SIO	✓	✓
YASKAWA Electric Corporation	Inverter SIO *2	✓	✓
Hitachi IES Co., Ltd.	Inverter ASCII SIO ※ 1	✓	✓
	InverterModbus RTU ※ 1	✓	✓

Fieldbus			
Manufacturer	Series	GP3000	ST3000
PROFIBUS International	PROFIBUS DP Slave	✓*3	-
ODVA	DeviceNet Slave	✓*3	-
CC-Link Partner Association	CC-Link Intelligent Device	✓*3	-

Industrial Robot			
Manufacturer	Series	GP3000	ST3000
Hyundai Heavy Industries	Hi4 Robot	✓	✓
IAI Corporation	ROBO CYLINDER MODBUS SIO	✓	✓
	X-SEL Controller	✓	✓

Other Devices			
Manufacturer	Series	GP3000	ST3000
Digital Electronics Corporation	Memory Link *4	✓	✓
	General SIO *1 *5	✓	✓
	General Ethernet *5	✓	-
MODBUS IDA	General MODBUS TCP Master *1	✓	-

\*1 These drivers are under development as of October 2008.

\*2 GP-Pro EX V2.2 doesn't have these drivers. Please download from our web site "Otasuke Pro!"

\*3 GP3000H doesn't support this connection.

\*4 The product doesn't need to choose a host controller like PC, Microcomputer board, etc. It communicates via the storage space built into the main unit.

\*5 A program driver for the send/receive command process by D-Script.

**4.2 Shapes of COM ports**

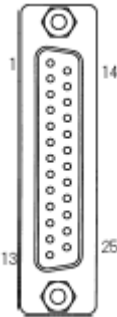
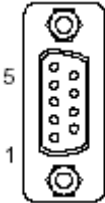
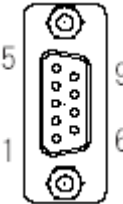
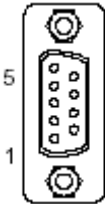
	GLC2000 Series	GP3000 Series
COM1	D-Sub 25 pin (female) RS-232C/422	D-Sub 9 pin (male) RS-232C/485 (422) compatible
		
COM2	D-Sub 9 pin (male) RS-232C	D-Sub 9 pin (female) RS-485 (422) compatible
		

**NOTE**

The number of pins and signals of Serial Interface differ between GLC2000 series and GP3000 Series. A wiring method at the time of replacement varies depending on a used connection device/PLC. Please check with [Connectable Controllers for GP3000 Series] of our support web site, [Otasuke Pro!];

<http://www.pro-face.com/otasuke/qa/gp3000/replace/connect/connect.php?rm=2>

4.2.1 Signals on COM1

► GLC2000 series: RS232C or 422

Pin Assignments	Pin #	Signal Name	Condition
<p>(D-Sub 25pin female)</p> <p>SIO</p>	1	FG	Frame ground
	2	SD	Send data (RS-232C)
	3	RD	Receive data (RS-232C)
	4	RS	Request send (RS-232C)
	5	CS	Clear send (RS-232C)
	6	DR	Data Set Ready (RS-232C)
	7	SG	Signal ground
	8	CD	Carrier detect (RS-232C)
	9	TRMX	Termination (RS-422)
	10	RDA	Receive data A (RS-422)
	11	SDA	Send data A (RS-422)
	12	NC	No connection (Reserved)
	13	NC	No connection (Reserved)
	14	VCC	5V±5% output 0.25A
	15	SDB	Send data B (RS-422)
	16	RDB	Receive data B (RS-422)
	17	RI	Ring Indicate (RS-232C)
	18	CSB	Clear send B (RS-422)
	19	ERB	Enable receive B (RS-422)
	20	ER	Enable receive (RS-232C)
	21	CSA	Clear send A (RS-422)
	22	ERA	Enable receive A (RS-422)
	23	NC	No connection (Reserved)
	24	NC	No connection (Reserved)
	25	NC	No connection (Reserved)

► GP3000 Series

RS232C

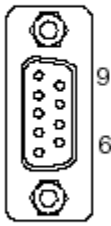
Pin Arrangement	Pin No.	RS232C		
		Signal Name	Direction	Meaning
 <p>(GP unit side)</p>	1	CD	Input	Carrier Detect
	2	RD(RXD)	Input	Receive Data
	3	SD(TXD)	Output	Send Data
	4	ER(DTR)	Output	Data Terminal Ready
	5	SG	-	Signal Ground
	6	DR(DSR)	Input	Data Set Ready
	7	RS(RTS)	Output	Request to Send
	8	CS(CTS)	Input	Send Possible
	9	CI(RI)/VCC	Input/-	Called status display +5V±5% Output 0.25A *2
	Shell	FG	-	Frame Ground (Common with SG)

RS485 (422)

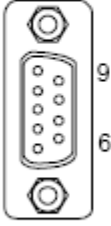
Pin Arrangement	Pin No.	RS422/RS485		
		Signal Name	Direction	Meaning
 <p>(GP unit side)</p>	1	RDA	Input	Receive Data A(+)
	2	RDB	Input	Receive Data B(-)
	3	SDA	Output	Send Data A(+)
	4	ERA	Output	Data Terminal Ready A(+)
	5	SG	-	Signal Ground
	6	CSB	Input	Send Possible B(-)
	7	SDB	Output	Send Data B(-)
	8	CSA	Input	Send Possible A(+)
	9	ERB	Output	Data Terminal Ready B(-)
	Shell	FG	-	Frame Ground (Common with SG)

4.2.2 Signals on COM2

► GLC2000 Series: RS232C

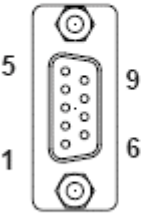
Pin Assignments	Pin No.	Signal Name	Signal Direction	Condition
(D-Sub 9pin male) 	1	CD	Input	Carrier detect (RS-232C)
	2	RD	Input	Receive data (RS-232C)
	3	SD	Output	Send data (RS-232C)
	4	ER	Output	Enable receive (RS-232C)
	5	SG	—	Signal Ground
	6	DR	Input	Data Set Ready (RS-232C)
	7	RS	Output	Request Send (RS-232C)
	8	CS	Input	Clear send (RS-232C)
	9	R/VCC	Input/Output	Ring Indicate (RS-232C) +5V+5% 0.25A

► GP3000 Series: RS485 (422)

Pin Arrangement	Pin No.	RS422/RS485		
		Signal Name	Direction	Meaning
 (GP unit side)	1	TRMRX	-	Termination (Receiver side: 100Ω)
	2	RDA	Input	Receive Data A(+)
	3	SDA	Output	Send Data A(+)
	4	RS(RTS)	Output	Request for Send
	5	SG	-	Signal Ground
	6	VCC	-	+5V±5% Output 0.25A *1
	7	RDB	Input	Receive Data B(-)
	8	SDB	Output	Send Data B(-)
	9	TRMTX	-	Termination (Receiver side: 100Ω)
	Shell	FG	-	Frame Ground (Common with SG)

When connecting 2 devices whose connection interfaces are 232C to the GLC2000 series...

If you connected a device/PLC, whose connection interface is RS-232C, to the COM1 port on the GLC2000 series and another device such as a barcode reader, whose connection interface is also RS-232C, to the COM2 port, connect the devices to the GP3000 series as below after conversion.

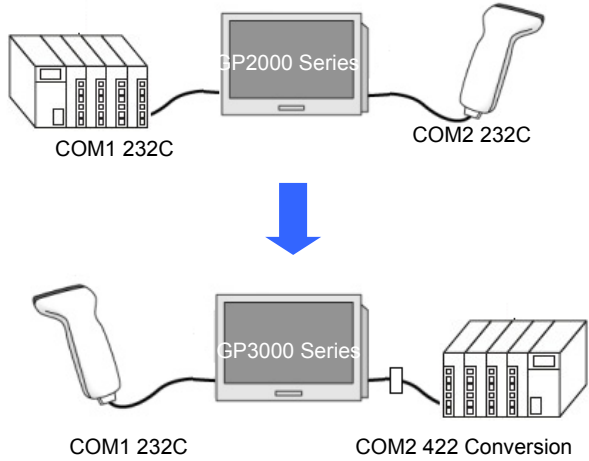

### 4.3 Multilink Connection

The GP3000 series does not support multilink connection via RS-422. If you convert a project file with the “n to 1” setting, it will be converted to the “1 to 1 connection” automatically.

- Settings on GP-PRO/PBIII for Windows

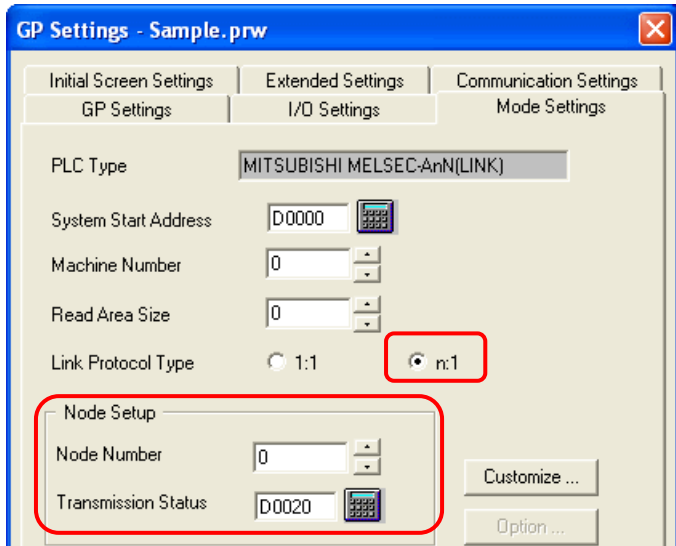

For the information on how to replace units with multilink connection, please contact the nearest Pro-face office.