

# GP-2501S

## Backlight Replacement Guide

Thank you for purchasing the PS501S-BU00 replacement backlight.

Be sure to read the following Backlight Replacement Warnings prior to replacing your GP unit's backlight.

This replacement backlight package contains the following:

GP Model Name	Backlight Model
GP-2501S	PS501S-BU00

This backlight's service life is 50,000 hours (approximately 5.7 years) under normal conditions (24-hour continuous operation and normal temperature). The service life will vary depending on your usage environment.

If this backlight is not appropriate for your GP or does not function correctly, please contact your local authorized GP representative.

### WARNINGS

- Be sure the GP unit's power cord has been disconnected before changing the backlight. When the GP's power cord is connected and the power supply is ON, high voltage runs through the wires in the backlight area.
- After the GP unit's power cord is disconnected, the backlight area will remain hot for a short period. Be sure to wear gloves to prevent burns.
- Do not touch the backlight unit's glass tube directly or try to remove its power cord. If the glass tube breaks you may be injured.



- *Do not allow water, oil or fingerprints to remain on the tube, since they can all reduce the backlight's life.*
- *When replacing the backlight, be sure to use the correct model backlight. (Model No: PS501S-BU00)*

#### ◆ Package Contents

- Two (2) replacement backlights (Model:PS501S-BU00)
- One (1) backlight replacement guide (this guide)

#### ◆ Items Required When Changing The GP's Backlight

- Phillips screwdriver (no. 2) for GP's rear cover attachment screws.
- One pair of clean (preferably new) cotton gloves.

Also, Pro-face recommends you prepare a small container for keeping all screws removed during the replacement process.

## ■ Backlight Replacement

Follow the procedures given below to replace the GP-2501S unit's backlights. Be sure to wear gloves during replacement.



- Be sure to protect the GP front panel's surface to prevent damage.
- The GP-2501S has an upper and a lower backlight. Be sure to replace both.
- Dispose of the old CCFL backlights according to the applicable laws and regulations of your local government.
- The backlight unit includes both the tube and holder. Do not attempt to separate the two, since the unit could break and cause an injury.
- The upper and lower backlight units are unique and cannot be used for the opposite side.

**I.e. the upper unit can only be used for replacing the upper backlight and vice versa. Be sure to check each unit before installing.**

- 1) Turn off the GP-2501S unit's power supply. Remove the three (3) rear-face I/F covers and seven (7) cover attachment screws.



*Do not let the attachment screws fall inside the GP-2501S.*

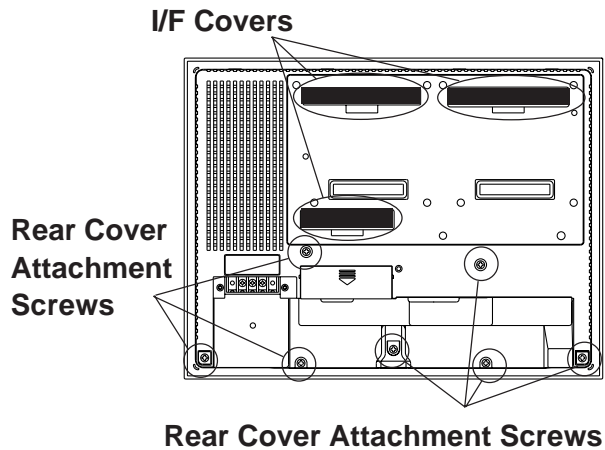

- 2) The top face of the rear cover uses four (4) alignment tabs. Open the rear cover from the bottom of the unit to free these tabs.



*Be sure to open the cover from the bottom of the GP. Attempting to open the cover from the top of the GP could damage the alignment tabs.*

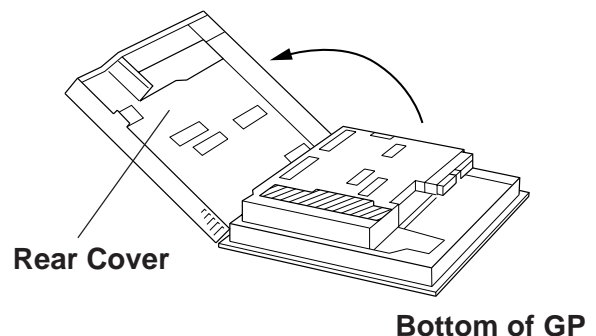

- 3) Remove the three (3) circuit board chassis set screws.

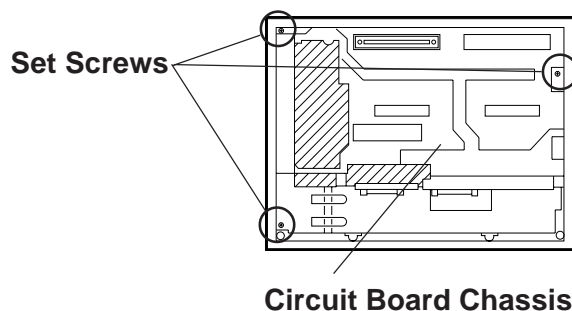

- 4) Pivot the circuit board chassis open from left to right, as shown here.



*A hot circuit board chassis can burn you. Be sure the chassis has cooled completely prior to replacing the backlights.*

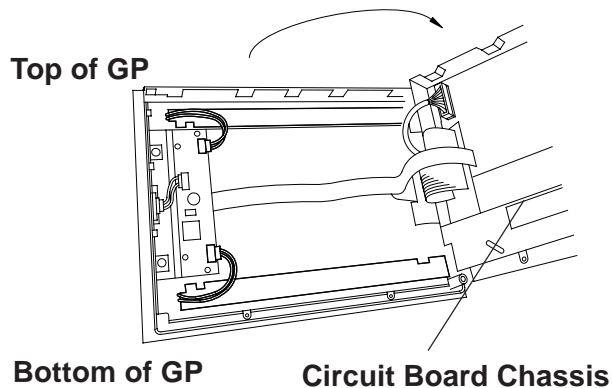

- 5) Detach the lower backlight unit's power connector from the inverter board.

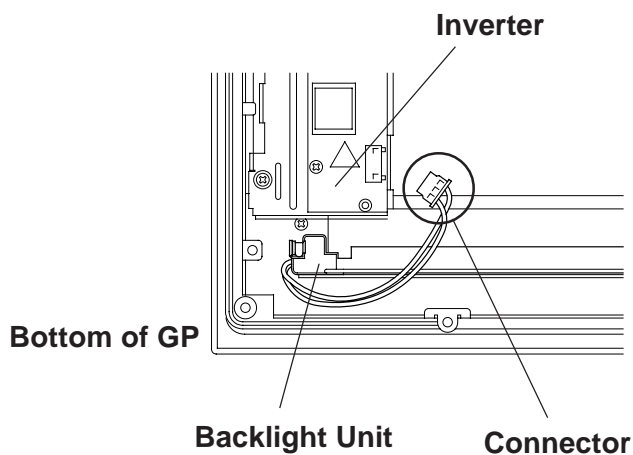

- 6) As shown here, push the backlight unit's attachment clip to the right to release the backlight unit.

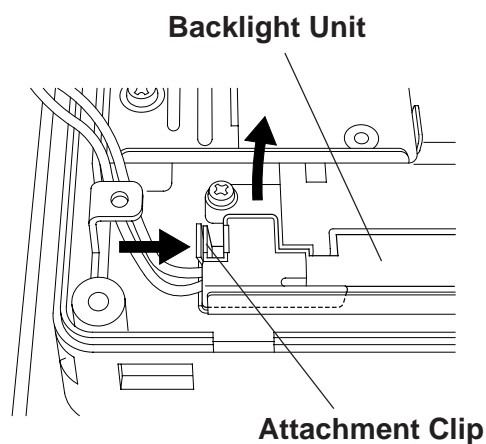

- 7) After the backlight unit is released, pull the unit slowly to the left to remove it from the GP unit.

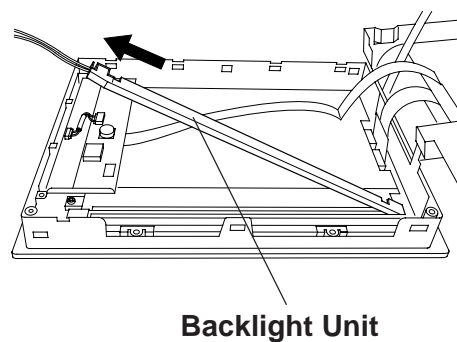

- 8) Insert the new lower backlight unit into the backlight holder as shown here. After the backlight is completely inserted and the attachment clip clicks into place, lower the unit into the GP.

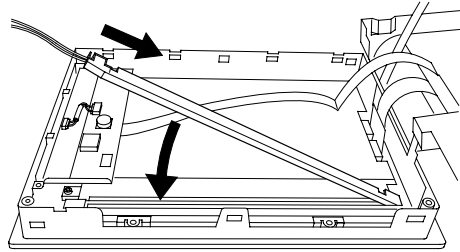

*Be careful that no dust or dirt adheres to the backlight surface or to the backlight holder.*

*Be sure to handle the replacement backlight unit carefully, since it can be easily damaged or broken.*

- 9) Confirm that the backlight unit is securely in place and reattach the backlight unit power connector.



*When replacing the Backlight unit, be sure not to catch any wiring on the edge of the unit. If a wire is caught and becomes cut, it could cause a fire.*

- 10) Replace the upper backlight unit by repeating the procedures shown in steps (5) to (9).

- 11) Return the circuit board chassis to its original position and reattach the rear cover by reversing steps (1) to (4).



*If any of the screws is missing, check if it fell inside the GP-2501S unit's chassis. If the power is turned ON while a screw is inside, it may cause an accident or fire.*

---

After backlight replacement is completed, turn the GP-2501S unit's power ON and check if the screen's display is normal. If the display is not correct, please contact the Pro-face distributor from whom you purchased the backlight unit.

---

### Note

Please be aware that Digital Electronics Corporation shall not be held liable by the user for any damages, losses, or third party claims arising from the uses of this product.

**Digital Electronics Corporation**

8-2-52 Nanko Higashi, Suminoe-ku, Osaka 559-0031, Japan

URL: <http://www.pro-face.com/>

---

© 2002 Digital Electronics Corporation. All rights reserved.

PS501S-BU00-MT01-CP 2002.2 A