

Terminal Block Conversion Adapter CA3-ADPTRM-01 Installation Guide

Thank you for purchasing Digital Electronics Corporation's Terminal Block Conversion Adapter (CA3-ADPTRM-01). This Terminal Block Conversion Adapter is connected via a serial interface (COM) to Digital's AGP Series units, and converts this interface to an RS422 terminal block.

Prior to using this product, be sure to read this document as well as your AGP Series unit's manual. For PLC connection information, refer to your "External Device Drivers" Manual.

Safety Precautions

This guide contains a variety of safety markings related to the safe and correct operation of the Terminal Block Conversion Adapter. Be sure to read this guide and any related manuals carefully to fully understand how to correctly use this adapter.

■ Safety Symbol

This guide uses the following safety-related symbol. Please pay attention to this symbol and follow the instructions given.



Indicates situations that may result in major machine damage, severe bodily injury, or death if the instructions are not followed.



- Do not disassemble or remodel this adapter in any way. Doing so may cause an electric shock or fire.
- Do not use this adapter in areas where flammable gases are present. Doing so may cause an explosion.

■ To Prevent Terminal Block Conversion Adapter Damage

- Be sure not to connect a cable to the Terminal Block Conversion Adapter while it is attached to the AGP unit. Doing so can damage the Terminal Block Conversion Adapter.
- Do not allow water to enter the connector. Also, do not touch the connector if your hands are wet. Doing so may cause an electric shock.
- Do not connect or disconnect the Terminal Block Conversion Adapter during data transfer. Doing so may cause a data communication error.
- When attaching a cable that uses a lay wire, be sure to twist the cable core's wires. Failure to do so can lead to a short circuit if wire strands contact another strand or a nearby electrode.

Package Contents

■ Terminal Block Conversion Adapter (1)
(CA3-ADPTRM-01)

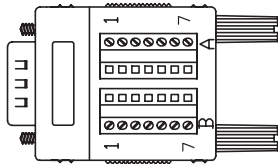

■ Installation Guide (This Guide)

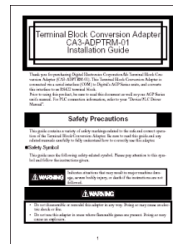

This unit has been carefully packed, with special attention to quality. However, if for any reason you find any of the contents of this package damaged or missing, please contact your local Pro-face representative immediately.

Dimensions and Cable Diagram

The following data indicates the Terminal Block Conversion Adapter's dimensions and cable diagram.

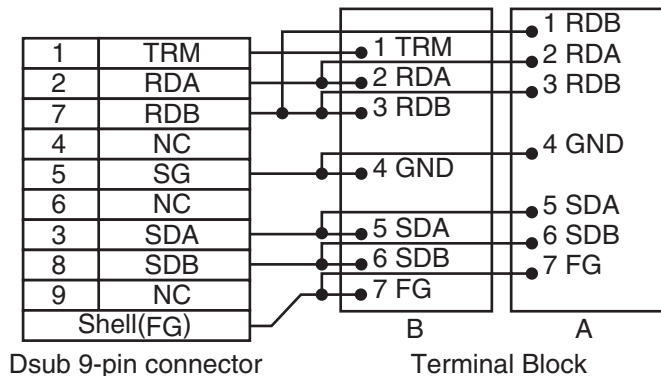
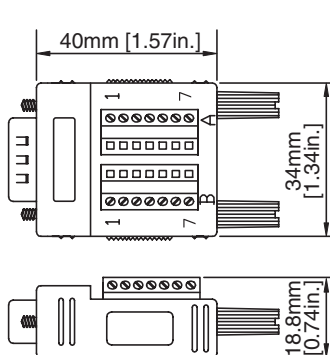

Wiring

The following information explains the communication cable's wiring method and usage cautions.

■ Direct Connection Specifications

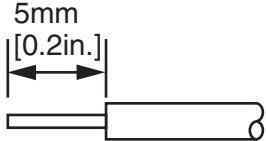
Wire Type	Simple wire or Lay wire
Cable dimensions (cross section)	Simple wire: 0.14mm ² to 1.5mm ² Lay wire: 0.14mm ² to 1.0mm ² Cable size: 26AWG to 16AWG
Strip Length	5mm [0.2in.] 

■ Pin Terminal Specifications when using Crimp Terminals

Please use the following items when creating a cable. All items listed below are made by Phoenix Contact.

Recommended Driver	SZF 0-0,4X2,5 (1204504)
Recommended Pin Terminals	A 0,34-7 (3009202) A 0,5-6 (3200218)
Recommended Crimping Tool	CRIMPFOX ZA 3 (1201882)

IMPORTANT

- When attaching terminal screws, be sure to use a standard (flat-blade: 0.4 x 2.5) type screwdriver.
- The appropriate torque is 0.22N•m to 0.25N•m.
- Do not solder the cable's joined section.
- When attaching a cable that uses a lay wire, be sure to twist the cable core's wires. Failure to do so can lead to a short circuit if wire strands contact another strand or a nearby electrode.
- To prevent Terminal Block Conversion Adapter cables from being pulled out, be sure to bundle the cables externally.

NOTE

- Digital's Terminal Block Conversion Adapter cannot be connected to the Mitsubishi PLC 2Port Adapter (GP030-MD11-0). However, it can be connected to Digital's Mitsubishi PLC A, QnA, FX Series 2Port Adapter II (GP070-MD11).
- The AGP unit's serial interface (COM) has a termination resistance. When termination resistance is needed, shorting the terminal block adaptor's TRM and RDB wires inserts 100Ω of resistance between RDA and RDB.

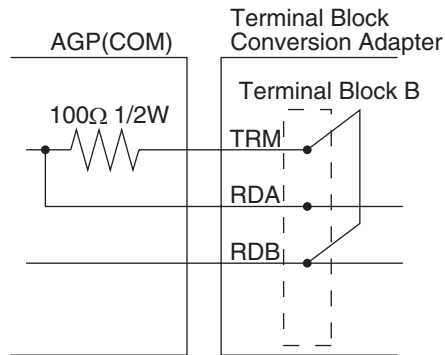

Connection Information

The wired Terminal Block Conversion Adapter will be connected to AGP's Serial Interface (COM).

If you use the plug-type serial interface on your AGP unit, be sure to use Pro-face's COM Port Conversion Adapter (CA3-ADPCOM-01)(sold separately).

Notice

Be aware that the Digital Electronics Corporation shall not be held liable for any real or estimated damages or losses, or third party claims resulting from the use of this product.

All Company/Manufacturer names used in this installation guide are the registered trademarks of those companies.