

MPI Cable ST03-A2B-MPI21-PFE Installation Guide

Thank you for purchasing Pro-face's MPI Cable (ST03-A2B-MPI21-PFE). This cable is designed to establish the communication between ST403 and AGP3302B* Touch panel serial port and a PLC by using MPI

1 Essential Safety Precautions

2 !!WARNINGS!!

- Attach the connector marked with "PLC side" to the port of the PLC. Otherwise a serious short cut will happen to the PLC port, which can damage the port.
- To avoid an electric shock, prior to connecting this unit to the display's serial interface, confirm that the display's power is completely turned OFF, via a breaker, or similar unit.
- Do not modify this unit. Doing so may cause a fire or an electric shock.
- Do not use this unit in an environment where flammable gases are present, since operating this unit may cause an explosion.

General Safety Precautions

- Do not allow water, liquids, metal or charged particles to enter inside the connectors of this cable, since they can cause either malfunction or an electrical shock.
- Do not use or store this cable in direct sunlight, or in excessively dusty or dirty environments.
- Do not store or use this cable where strong jolting or excessive vibration can occur.
- Do not store or use this unit where chemicals (such as organic solvents, etc.) and acids can evaporate, or where chemicals and acids are present in the air.

3 Package contents

Please check that the following items are included in your package.

- MPI cable (ST03-A2B-MPI21-PFE)
- Installation Guide (this guide)

4 Cable Diagram

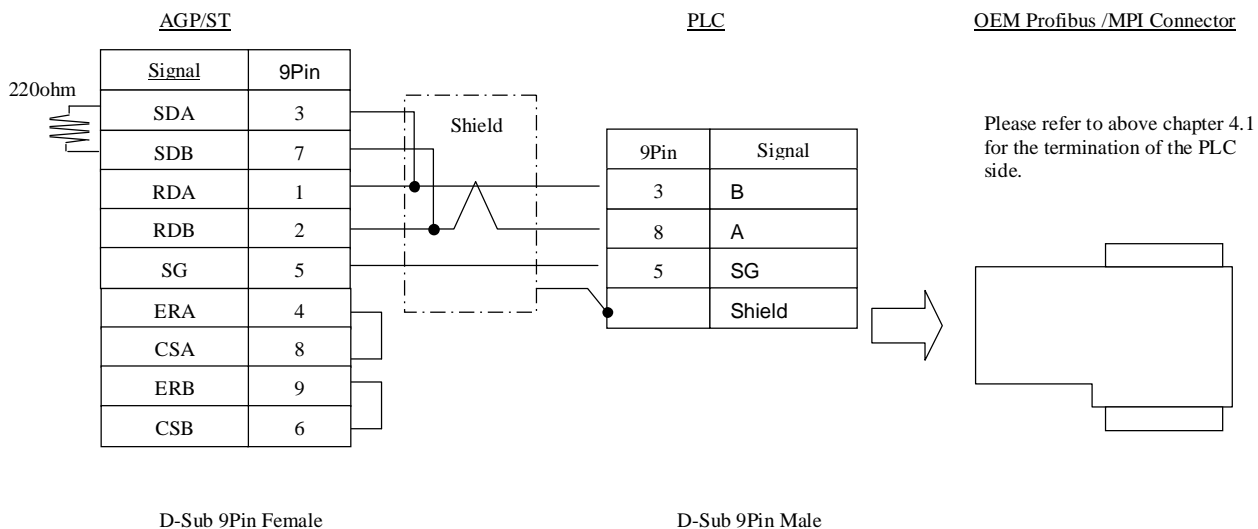

4.1 Termination

Inside the Profibus/MPI connector a 220Ω termination resistor is provided with a 390Ω pull up resistor and a 390Ω pull down resistor conform to the Profibus specifications [1].

A switch is provided to switch the termination on or off. In order to make a stable communication it is recommended to switch the termination resistor on.

5 Attachable Models

The following AGP/ST Series units are connectable with the MPI cable. (As October, 2005)

ST400 Series	AGP3000 Series
ST403-AG41-24V	AGP3302-B1-D24

*For future Touch panels which might be attachable, please refer to the corresponding chapter in the latest PLC Connection Manual of the GP PRO EX Software.

For PLC models attachable, please refer to the corresponding chapter in the PLC Connection Manual of the GPPRO Ex Software.

6 Supported Baud Rates

Supported Baud Rates / Line Rates as tested

9.6kbps	3.5m	1:1 connection
19.2kbps	3.5m	1:1 connection
45.45kbps	3.5m	1:1 connection
93.75kbps	3.5m	1:1 connection
187.5kbps	3.5m	1:1 connection

The cable is only recommended for 1:1 connection (1 AGP/ST and 1 PLC). In case of 1 : N or N: 1 Networks please refer to the corresponding chapter of the PLC Connection Manual of the GPPRO EX Software.



Pro-face Europe B.V.
Wegalaan 32
2132 JC Hoofddorp
The Netherlands
Tel: +31 (0)23 55 44 099
Fax: +31 (0)23 55 44 090

Pro-face Deutschland GmbH
Albertus Magnus Strasse 11
42719 Solingen
Germany
Tel: +49 212 2592 60
Fax: +49 212 2582 640

Pro-face UK Ltd.
Pro-face House,
8 Orchard Court
Binley Business Park
CV3 2TQ, Coventry
United Kingdom
Tel: +44 2476 440088
Fax: +44 2476 440099

Pro-face France S.A.S
Zone Mitry Compans Le Vince
1 Reu Henri Becquerel
77290 Mitry Mory
France
Tel: +33 160 212291
Fax: +33 160 212292

Pro-face Italia Spa
G di Vittorio 26
Bovisio Masciago
20030 Milano
Italy
Tel: +39 0362 59961
Fax: +39 0362 599699

Pro-face Scandinavia ApS
Copenhagen
Produktionsvej 26
2600 Glostrup
DENMARK
Tel.: +45 (0) 70 22 01 22
Fax: +45 (0) 70 22 01 33

Pro-face HMI Spain S.L.
Avda. Eduardo Corbella, 168 Local B
Aportado de Correos, 62
08440 Cardedue – Barcelona
Tel.: +34 93 8460745
Fax: +34 93 8454868

Note:
Please be aware that Pro-face Europe B.V.
shall not be held liable by the user for any damages,
losses, or third party claims arising from the uses of
this product.